

门窗及其他型材系列

Door & window series and other profiles

Guangdong Jma Aluminium Profile Factory Co., Ltd. is a comprehensive large size enterprise integrating research, design, production and sales of aluminium alloy profiles for building and industrial applications as well as windows, doors and curtain walls. The powerful comprehensive technology.

Catalogue 2022

普通推拉型材系列

1、窗系列

JM76B系列推拉窗	001-006
JM78系列推拉窗	007-011
TC80-D2系列推拉窗	012-013
JM85系列推拉窗	014-023
TC88系列推拉窗 (T=1.6)	024-025
A90系列推拉门窗	026-033
TC90-B8系列推拉窗 (T=1.6)	034-035
TC90-12系列推拉窗 (T=1.8mm)	036-037
JM95-IV系列推拉门窗	038-042

2、门系列

TM80系列推拉门	043-044
JM85系列推拉门	045-048
TM88-2系列推拉门 (单双轨)	049-051
TM90-07系列推拉门 (T=2.2)	052-053
TM95系列推拉门	054-056
JM95-II系列推拉门	057-059
JM95A-1系列推拉门	060-061
TM100-5系列推拉门 (两轨/三轨)	062-065
TM100A-7系列单轨推拉门	066-067
TM130-C1系列推拉门 (单双轨)	068-070
TM168系列推拉门 (三轨)	071-072

3、提升推拉门/重型门系列

TM80系列重型推拉门窗	073-076
TM120系列重型推拉门	077-080
TM130B系列重型推拉门	081-083
TM120系列提升推拉门	084-086
TM120A-9系列提升推拉门	087-088
TM130-A6系列提升推拉门	089-090
TM140-A0系列提升推拉门	091-092
TM140-03系列提升推拉门 (T=2.2)	093-094
TM165系列提升推拉门	095-096

普通平开型材系列

1、50平开门窗系列

50B系列平开窗	097-100
50G系列平开窗	101-103
E50系列平开窗	104-107
G50系列平开窗	108-110
JM50系列平开窗	111-114
JM50系列内开内倒窗	115-116
JM50-D1系列平开窗 (内外平)	117-119
H50B系列平开窗 (T=1.6)	120-121
H50-B0系列平开窗 (T=1.8/内外平)	122-123
PC50-19系列平开窗 (T=1.8)	124-125
PM50-I系列平开门窗	126-127
PM50-II系列平开门窗	128-129
PM50C系列平开门窗	130-132
PM50C-1系列平开门	133-134
PM50-F1系列平开门	135-136
PM50-E7系列平开门 (T=2.2)	137-138
PM50-08系列平开门 (T=2.2)	139-140

2、55平开门窗系列	
JM558系列平开窗	141-142
JM55A-I系列平开窗	143-148
PC55-B1系列平开窗(T=1.6/内外平)	149-150
PM55-6系列平开门	151-152
PM55-A2系列平开门(T=2.2/内外平)	153-154
PM55-A5系列平开门(T=2.2)	155-156
3、60平开门窗系列	
PC60A-7系列平开窗	157-158
PC60-C7系列内平开窗	159-160
PC60-D0系列平开窗(T=1.6)	161-162
PC60-D4系列平开窗(T=1.8/内外平)	163-164
PC60-01系列平开窗(T=1.8)	165-166
PM60-9系列平开门(T=2.0)	167-168
PM60-A7系列平开门(T=2.0/内外平)	169-171
4、65/70平开门窗系列	
PM65-3系列平开门(T=2.2)	172-173
PC70A系列平开窗	174-175
PC70-B4系列平开窗(内外平)	176-177
PM70系列平开门	178-181
PM70A-3系列平开门	182-183
PC80系列内平开窗	184-185
PM90-6系列平开门(T=2.2)	186-187
5、地弹簧门系列	
DT45系列地弹簧门	188-189
JM46门系列地弹簧门	190-191
DT53系列地弹簧门	192-193
DT65系列地弹簧门(T=2.2)	194-195
PM70B-4系列地弹门	196-197
DT80系列地弹簧门	198-199
DT90系列地弹簧门	200-201
6、折叠门系列	
PM70B-3系列推拉折叠门	202-204
PM75系列推拉折叠门	205-206
PM90-4系列推拉折叠门	207-208
PM90-5系列推拉折叠门	209-210
PM95系列推拉折叠门	211-212
通用材系列	
扶手料	213-229
通用材表	230-256
转角系列	257
撞角系列	258-261
百叶片系列	262-264
卷帘片及扣板山槽系列	265
纱窗系列	266-267
压线压座系列	268-269
间墙料系列	270-271
包边料	272

Sliding window sections

1.Window sections	
Series JM76B Sliding window	001-006
Series JM78 Sliding window	007-011
Series TC80-D2 Sliding window	012-013
Series JM85 Sliding window	014-023
Series TC88 Sliding window	024-025
Series A90 Sliding window	026-033
Series TC90-B8 Sliding window	034-035
Series TC90-12 Sliding window	036-037
Series JM95-IV Sliding window	038-042
2.Door sections	
Series TM80 Sliding door	043-044
Series JM85 Sliding door	045-048
Series TM88-2 Sliding door	049-051
Series TM90-07 Sliding door	052-053
Series TM95 Sliding door	054-056
Series JM95-II Sliding door	057-059
Series JM95A-1 Sliding door	060-061
Series TM100-5 Sliding door	062-065
Series TM100A-7 Sliding door	066-067
Series TM130-C1 Sliding door	068-070
Series TM168 Sliding door	071-072
3.Door sections	
Series TM80 Sliding door	073-076
Series TM120 Sliding door	077-080
Series TM130B Sliding door	081-083
Series TM120 Sliding door	084-086
Series TM120A-9 Sliding door	087-088
Series TM130-A6 Sliding door	089-090
Series TM140-A0 Sliding door	091-092
Series TM140-03 Sliding door	093-094
Series TM165 Sliding door	095-096

Casement window sections

1.50 Window sections	
Series 50B Open-out Casement window	097-100
Series 50G Open-out Casement window	101-103
Series E50 Open-out Casement window	104-107
Series G50 Open-out Casement window	108-110
Series JM50 Open-out Casement window	111-114
Series JM50 Open-out Casement window	115-116
Series JM50-D1 Open-out Casement window	117-119
Series H50B Open-out Casement window	120-121
Series H50-B0 Open-out Casement window	122-123
Series PC50-19 Open-out Casement window	124-125
Series PM50-I Open-out Casement window	126-127
Series PM50-II Open-out Casement window	128-129
Series PM50C Open-out Casement window	130-132
Series PM50C-1 Open-out Casement door	133-134
Series PM50-F1 Open-out Casement door	135-136
Series PM50-E7 Open-out Casement door	137-138
Series PM50-08 Open-out Casement door	139-140

2.55 Window sections	
Series JM558 Open-out Casement window	141-142
Series JM55A-1 Open-out Casement window	143-148
Series PC55-B1 Open-out Casement window	149-150
Series PM55-6 Open-out Casement DOOR	151-152
Series PM55-A2 Open-out Casement DOOR	153-154
Series PM55-A5 Open-out Casement DOOR	155-156

3.60 Window sections	
Series PC60A-7 Open-out Casement window	157-158
Series PC60-C7 Open-out Casement window	159-160
Series PC60-D0 Open-out Casement window	161-162
Series PC60-D4 Open-out Casement window	163-164
Series PC60-01 Open-out Casement window	165-166
Series PM60-9 Open-out Casement DOOR	167-168
Series PM60-A7 Open-out Casement DOOR	169-171

4.65/70 Window sections	
Series PM65-3 Open-out Casement DOOR	172-173
Series PC70A Open-out Casement window	174-175
Series PC70-B4 Open-out Casement window	176-177
Series PM70 Open-out Casement DOOR	178-181
Series PM70A-3 Open-out Casement DOOR	182-183
Series PC80 Open-out Casement window	184-185
Series PM90-6 Open-out Casement DOOR	186-187

5. Door sections	
DT45 floor spring door	188-189
JM46 floor spring door	190-191
DT53 floor spring door	192-193
DT65 floor spring door	194-195
PM70B-4 floor spring door	196-197
DT80 floor spring door	198-199
DT90 floor spring door	200-201

6. Door sections	
PM70B-3 sliding & soldering door	202-204
PM75 sliding & soldering door	205-206
PM90-4 sliding & soldering door	207-208
PM90-5 sliding & soldering door	209-210
PM95 sliding & soldering door	211-212

General Shape Sections

Handrail	213-229
Standard Profile	230-256
Angles-pipe	257
Inside Angles	258-261
Louver, Heat sink and section	262-264
Roll Door section, Spandrel and Channel section	265
Mosquion Net section	266-267
Glazing Beat, Outer Frame and section	268-269
Partition section	270-271
Hemming profile	272

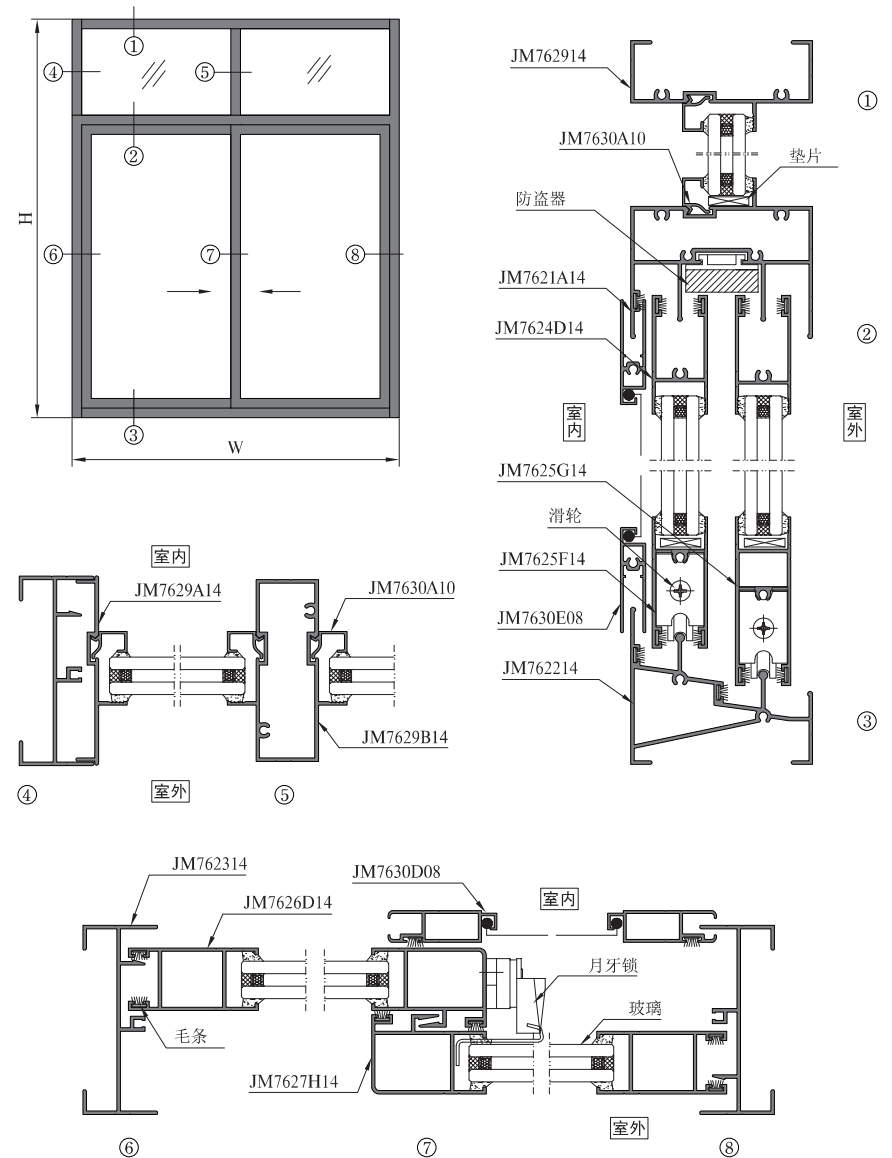

图中所示型材截面、装配、编号、尺寸及重量仅供参考。如有疑问，请向本公司查询。
 Information above just for your reference. Please contact us if you have any questions, Thank you!

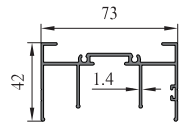
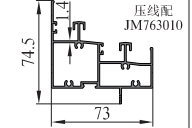
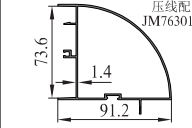
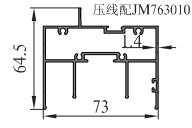
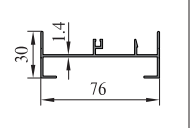
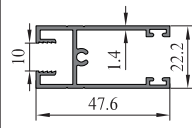
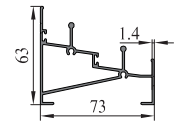
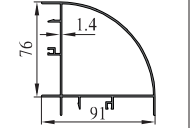
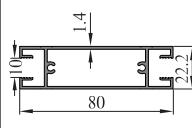
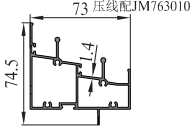
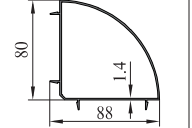
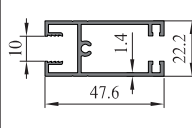
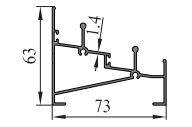
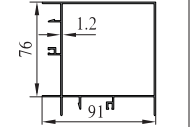
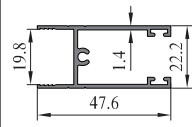
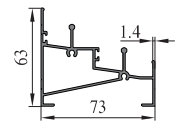
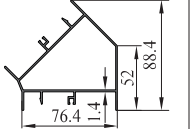
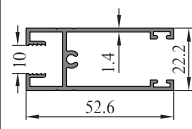
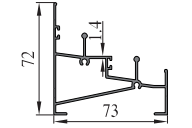
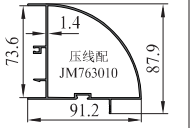
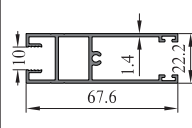
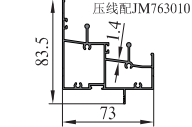
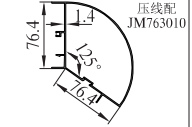
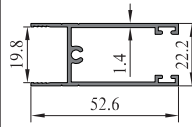
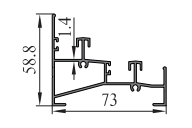
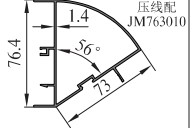
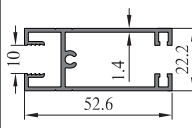
序号 S/N	型号理论重量 JMA Code & KG/M	型材图 Drawing	序号 S/N	型号理论重量 JMA Code & KG/M	型材图 Drawing	序号 S/N	型号理论重量 JMA Code & KG/M	型材图 Drawing
1	上滑 JM762114 1.011kg/m		10	固下滑 JM7622L14 1.567kg/m		19	转角 JM7623W14 1.412kg/m	
2	固上滑 JM7621A14 1.477kg/m		11	边封 JM762314 0.732kg/m		20	上方 JM762414 0.625kg/m	
3	下滑 JM762214 1.231kg/m		12	转角 JM7623C14 1.570kg/m		21	中横 JM7624A14 1.035kg/m	
4	固下滑 JM7622A14 1.474kg/m		13	转角 JM7623D14 1.264kg/m		22	上方 JM7624E14 0.660kg/m	
5	下滑 JM7622F14 1.231kg/m		14	转角 JM7623E12 1.487kg/m		23	上方 JM7624D14 0.530kg/m	
6	下滑 JM7622G14 1.278kg/m		15	转角 JM7623S14 1.429kg/m		24	下方 JM762514 0.666kg/m	
7	下滑 JM7622H14 1.291kg/m		16	转角 JM7623U14 1.412kg/m		25	下方 JM7625A14 0.868kg/m	
8	固下滑 JM7622J14 1.535kg/m		17	转角 JM7623UA14 1.620kg/m		26	下方 JM7625F14 0.571kg/m	
9	下滑 JM7622K14 1.230kg/m		18	转角 JM7623UB14 1.217kg/m		27	下方 JM7625H14 0.701kg/m	

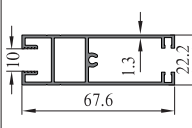
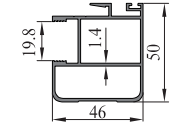
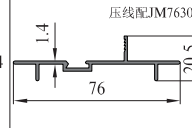
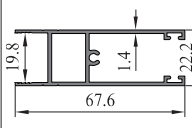
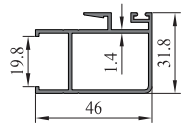
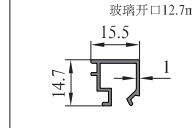
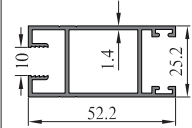
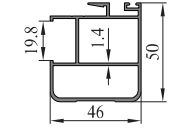
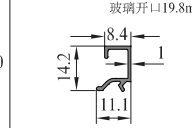
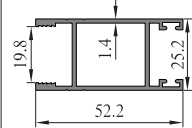
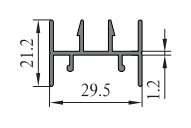
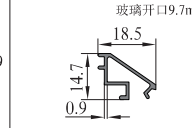
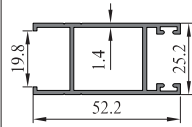
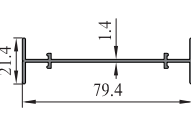
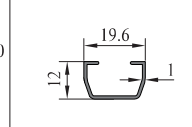
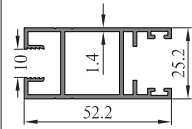
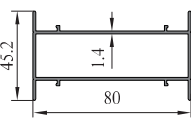
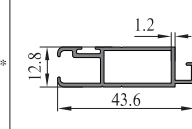
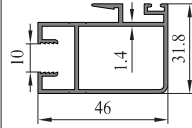
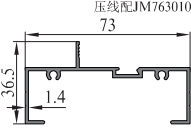
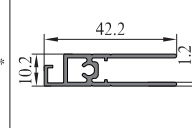
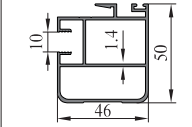
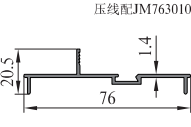
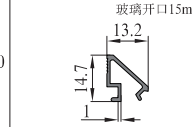
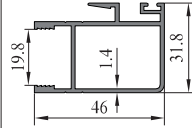
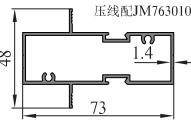
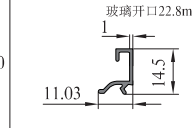

序号 S/N	型号理论重量 JMA Code & KG/M	型材图 Drawing	序号 S/N	型号理论重量 JMA Code & KG/M	型材图 Drawing	序号 S/N	型号理论重量 JMA Code & KG/M	型材图 Drawing
28	下方 JM7625K13 0.842kg/m		37	勾企 JM7627G14 1.076kg/m		46	插板 JM7629L14 0.449kg/m	
29	下方 JM7625G14 0.773kg/m		38	勾企 JM7627H14 0.701kg/m		47	压线 JM763010 0.154kg/m	
30	光企 JM762614 0.743kg/m		39	勾企 JM7627M14 1.042kg/m		48	压线 JM7630A10 0.109kg/m	
31	光企 JM7626C14 0.701kg/m		40	收口 JM762812 0.36kg/m		49	压线 JM7630B09 0.141kg/m	
32	光企 JM7626D14 0.667kg/m		41	拼管 JM7628A14 0.539kg/m		50	JM7630C10 0.133kg/m	
33	光企 JM7626G14 0.786kg/m		42	拼管 JM7628D14 1.045kg/m		51	纱窗 JM7630D12* 0.395kg/m	
34	勾企 JM762714 0.777kg/m		43	上固 JM762914 0.7kg/m		52	纱窗 JM7630E12* 0.376kg/m	
35	勾企 JM7627A14 1.119kg/m		44	插板 JM7629A14 0.449kg/m		53	压线 JM7630G10 0.124kg/m	
36	勾企 JM7627F14 0.734kg/m		45	中柱 JM7629B14 1.009kg/m		54	压线 JM7630H10 0.099kg/m	

图中所示型材截面、装配、编号、尺寸及重量仅供参考。如有疑问，请向本公司查询。
 Information above just for your reference. Please contact us if you have any questions, Thank you!

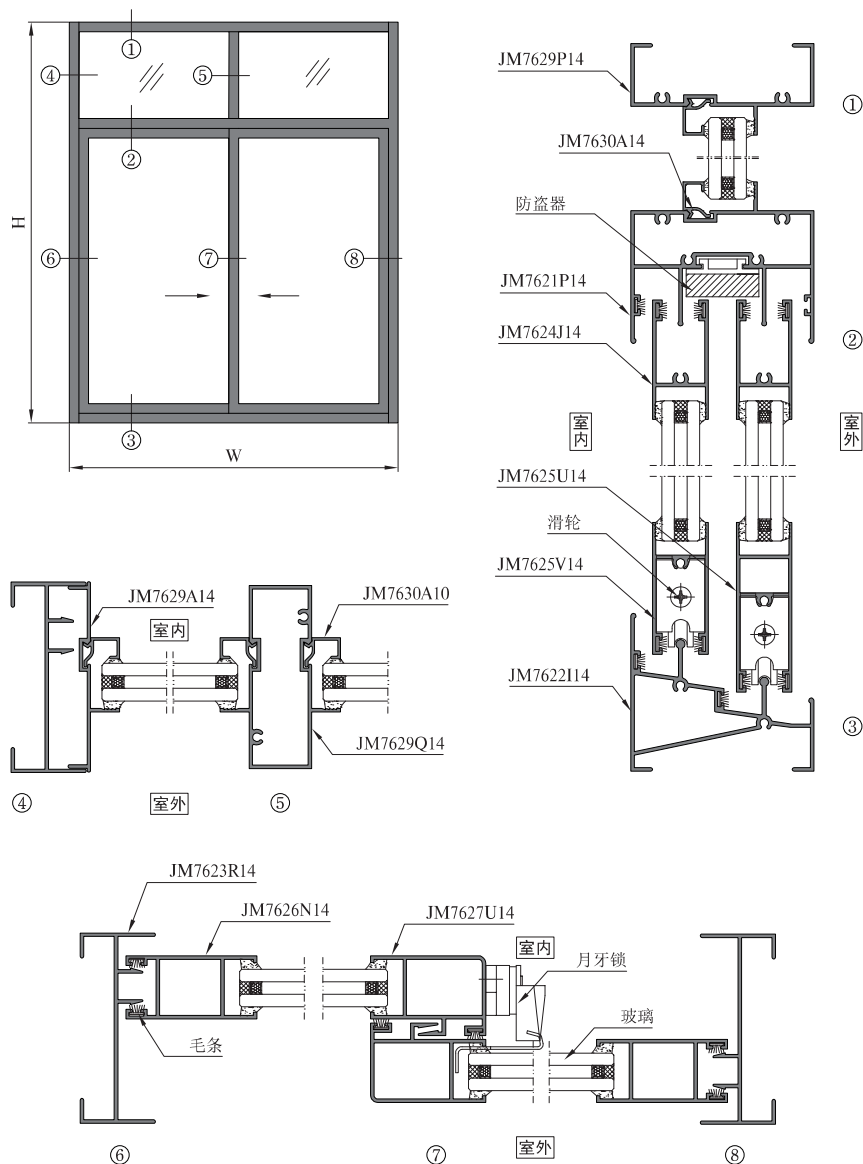
图中所示型材截面、装配、编号、尺寸及重量仅供参考。如有疑问，请向本公司查询。
 Information above just for your reference. Please contact us if you have any questions, Thank you!



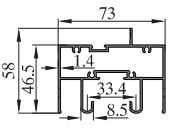
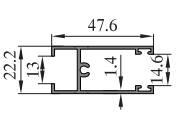
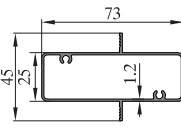
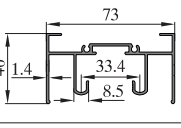
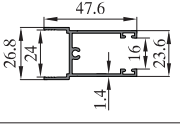
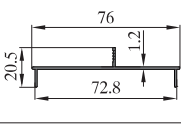
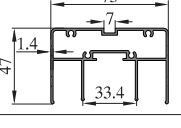
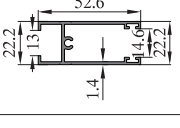
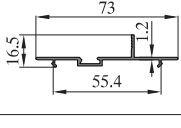
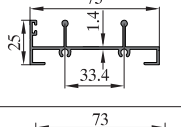
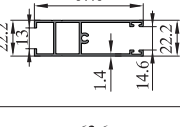
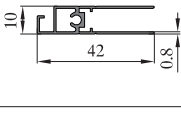
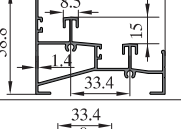
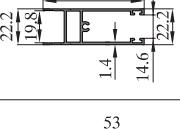
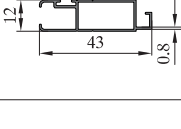
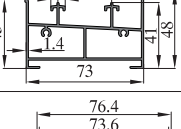
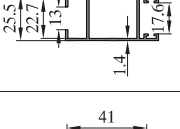
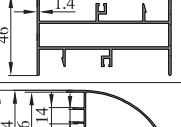
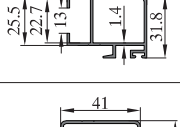
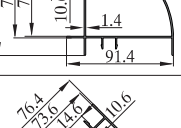
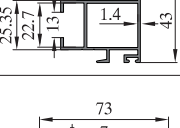

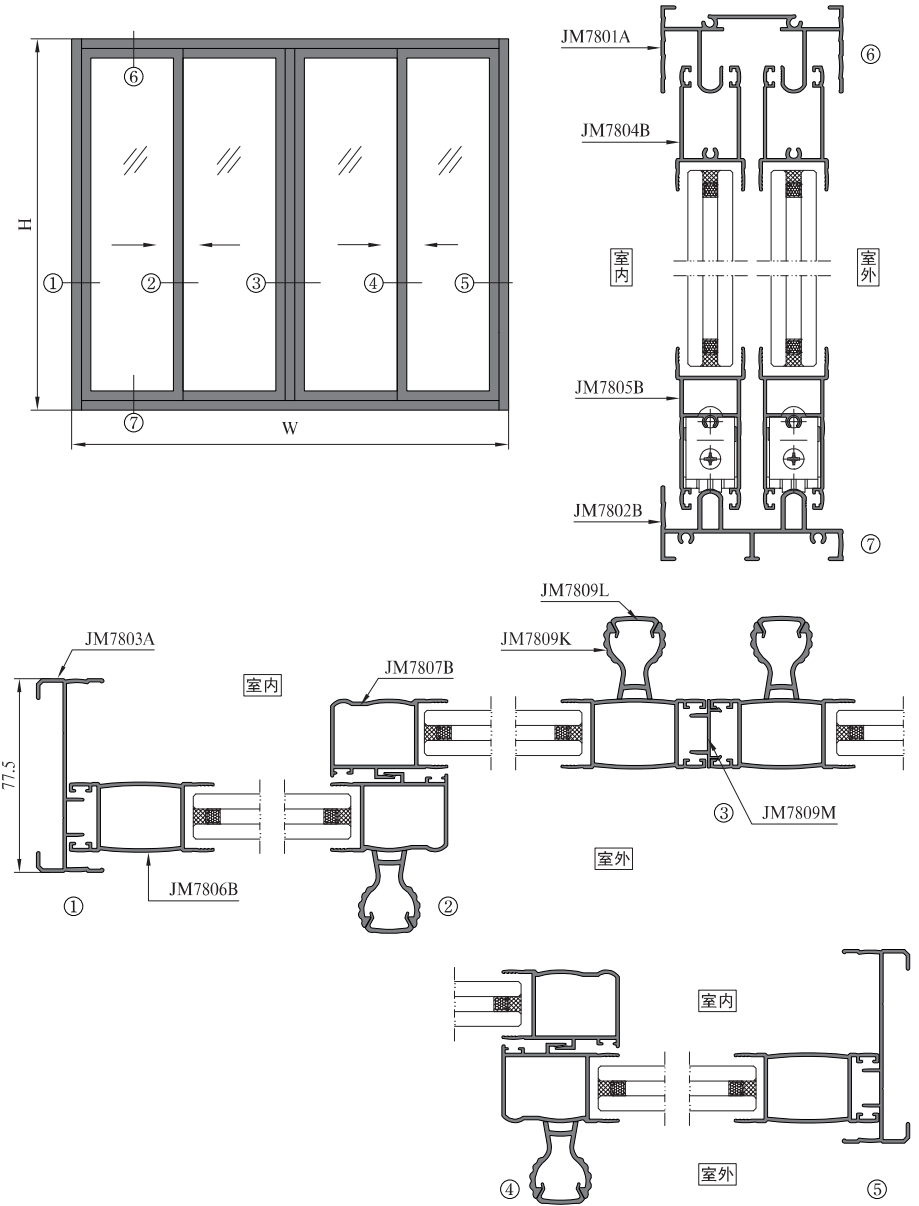

序号 S/N	型号理论重量 JMA Code & KG/M	型材图 Drawing	序号 S/N	型号理论重量 JMA Code & KG/M	型材图 Drawing	序号 S/N	型号理论重量 JMA Code & KG/M	型材图 Drawing
1	上滑 JM7621N14 1.038kg/m		10	光企 JM7626N14 0.667kg/m		19	压线 JM7630B09 0.141kg/m	 玻璃开口19.7mm
2	固定上滑 JM7621P14 1.509kg/m		11	勾企 JM7627T14 0.735kg/m		20	压线 JM7630G10 0.124kg/m	 玻璃开口15mm
3	下滑 JM7622I14 1.245kg/m		12	勾企 JM7627U14 0.702kg/m		21	压线 JM7630H10 0.099kg/m	 玻璃开口22.8mm
4	固定下滑 JM7622Z14 1.506kg/m		13	插板 JM7629A14 0.449kg/m		22	上方 JM7624RA14 0.647kg/m 带装饰线	
5	边封 JM7623R14 0.694kg/m		14	上固 JM7629P14 0.701kg/m		23	下方 JM7625X14 0.606kg/m 带装饰线	
6	上方 JM7624J14 0.517kg/m		15	中柱 JM7629Q14 1.01kg/m		24	下方 JM7625Y14 0.814kg/m 带装饰线	
7	下方 JM7625U14 0.760kg/m		16	插板 JM7629R14 0.426kg/m		25	光企 JM7626R14 0.664kg/m 带装饰线	
8	下方 JM7625V14 0.558kg/m		17	压线 JM7630I0 0.154kg/m		26	勾企 JM7627Z14 0.677kg/m 带装饰线	 玻璃开口12.7mm
9	光企 JM7626M14 0.702kg/m		18	压线 JM7630A10 0.109kg/m		27	压线 JM7630K10 0.096kg/m	 玻璃开口19.8mm

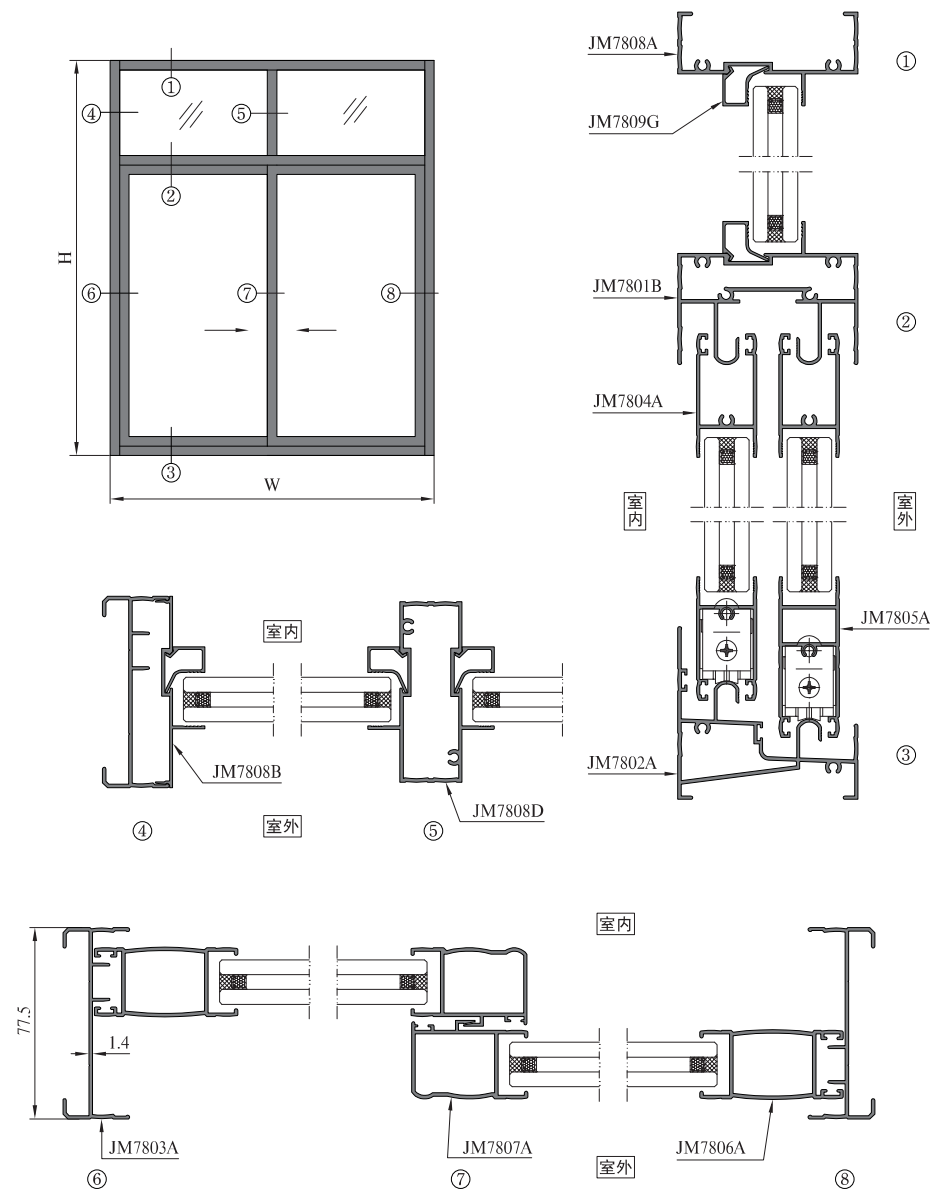
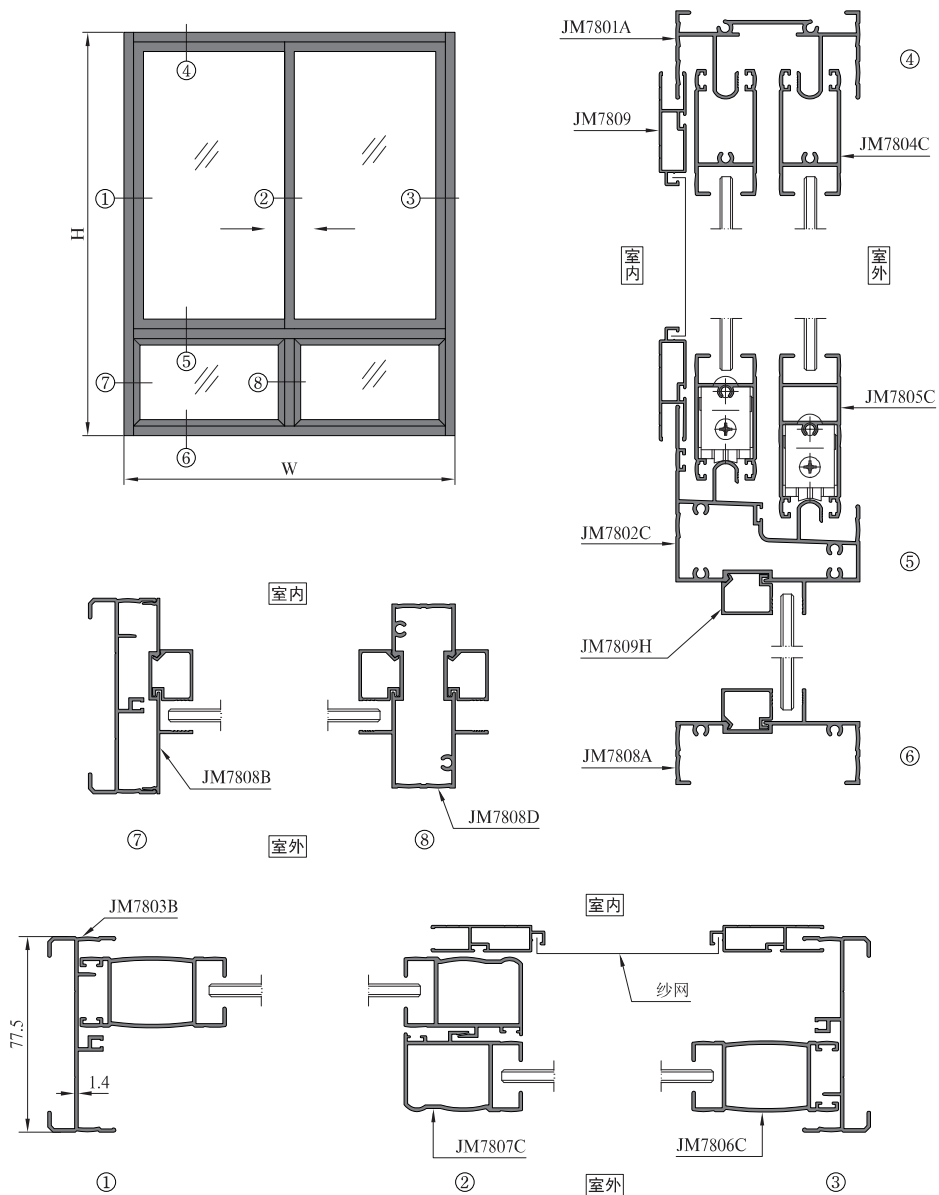
序号 S/N	型号理论重量 JMA Code & KG/M	型材图 Drawing	序号 S/N	型号理论重量 JMA Code & KG/M	型材图 Drawing	序号 S/N	型号理论重量 JMA Code & KG/M	型材图 Drawing
1	固上滑 JM7621AB14 T=1.40 1.464kg/m		10	上方 JM7624B14 T=1.40 0.591kg/m		19	中柱 JM7629K12* T=1.20 0.780kg/m	
2	上滑 JM7621AD14 T=1.40 1.042kg/m		11	上方 JM7624R14 T=1.40 0.565kg/m		20	边封插板 JM7629J12* T=1.20 0.367kg/m	
3	固上滑 JM7621H14 T=1.40 1.353kg/m		12	下方 JM7625B14 T=1.40 0.623kg/m		21	上下滑插板 JM7629R12* T=1.20 0.357kg/m	
4	下滑 JM7622ED14 T=1.40 0.730kg/m		13	下方 JM7625D14 T=1.40 0.825kg/m		22	纱窗 JM7630E08 0.280kg/m	
5	下滑 JM7622K14 T=1.40 1.230kg/m		14	下方 JM7625PA14 T=1.40 0.732kg/m		23	纱窗 JM7630D08 0.271kg/m	
6	下滑 JM7622LM14 T=1.40 1.373kg/m		15	光企 JM7626E14 T=1.40 0.713kg/m		24		
7	双边封 JM7623B14 T=1.40 1.214kg/m		16	勾企 JM7627B14 T=1.40 0.667kg/m		25		
8	转角 JM7623GB14 T=1.40 1.472kg/m		17	勾企 JM7627D14 T=1.40 0.912kg/m		26		
9	转角 JM7623SA14 T=1.40 1.352kg/m		18	上固 JM7629H14 T=1.40 0.678kg/m		27		

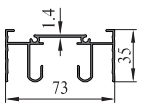
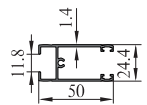
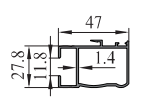
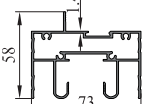
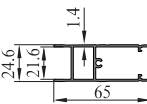
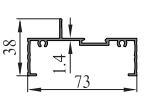
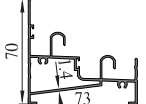
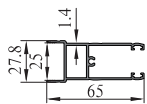
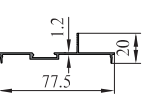
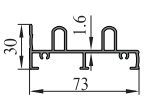
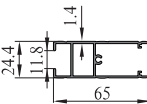
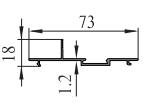
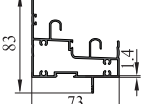
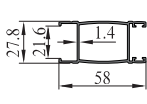
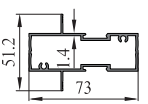
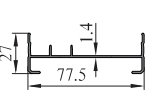
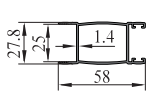
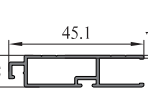
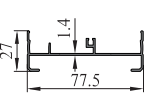
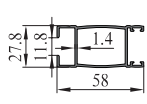
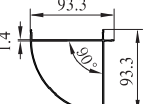
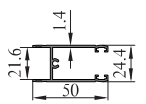
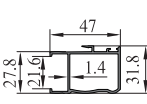
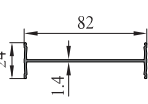
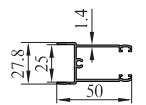
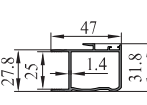

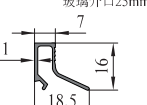
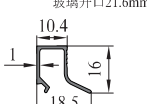
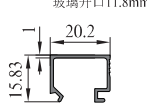
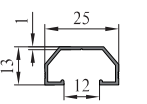
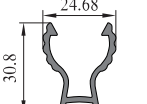
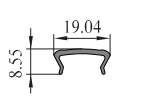
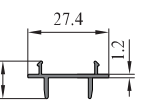
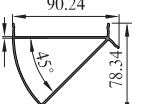

序号 S/N	型号理论重量 JMA Code & KG/M	型材图 Drawing	序号 S/N	型号理论重量 JMA Code & KG/M	型材图 Drawing	序号 S/N	型号理论重量 JMA Code & KG/M	型材图 Drawing
1	上滑 JM7801A 1.011kg/m		10	上方 JM7804C 0.615kg/m		19	勾企 JM7807C 0.694kg/m	
2	带固上滑 JM7801B 1.517kg/m		11	下方 JM7805A 0.788kg/m		20	上固 JM7808A 0.7kg/m	
3	下滑 JM7802A 1.31kg/m		12	下方 JM7805B 0.794kg/m		21	边封插板 JM7808B 0.38kg/m	
4	下滑 JM7802B 1.037kg/m		13	下方 JM7805C 0.826kg/m		22	反插板 JM7808C 0.359kg/m	
5	带固下滑 JM7802C 1.52kg/m		14	光企 JM7806A 0.726kg/m		23	中柱 JM7808D 1.042kg/m	
6	边封 JM7803A 0.616kg/m		15	光企 JM7806B 0.707kg/m		24	纱窗 JM7809 0.33kg/m	
7	边封 JM7803B 0.671kg/m		16	光企 JM7806C 0.766kg/m		25	转角 JM7809A 1.367kg/m	
8	上方 JM7804A 0.577kg/m		17	勾企 JM7807A 0.654kg/m		26	拼管 JM7809B 0.525kg/m	
9	上方 JM7804B 0.583kg/m		18	勾企 JM7807B 0.636kg/m		27	压线 JM7809E 0.15kg/m	

序号 S/N	型号理论重量 JMA Code & KG/M	型材图 Drawing	序号 S/N	型号理论重量 JMA Code & KG/M	型材图 Drawing	序号 S/N	型号理论重量 JMA Code & KG/M	型材图 Drawing
28	压线 JM7809F 0.135kg/m		37			46		
29	压线 JM7809G 0.138kg/m		38			47		
30	压线 JM7809H 0.174kg/m		39			48		
31	JM7809J 0.16kg/m		40			49		
32	拉手 JM7809K 0.422kg/m		41			50		
33	拉手盖板 JM7809L 0.13kg/m		42			51		
34	收口 JM7809M 0.176kg/m		43			52		
35	45° 转角 JM7809N 1.117kg/m		44			53		
36			45			54		

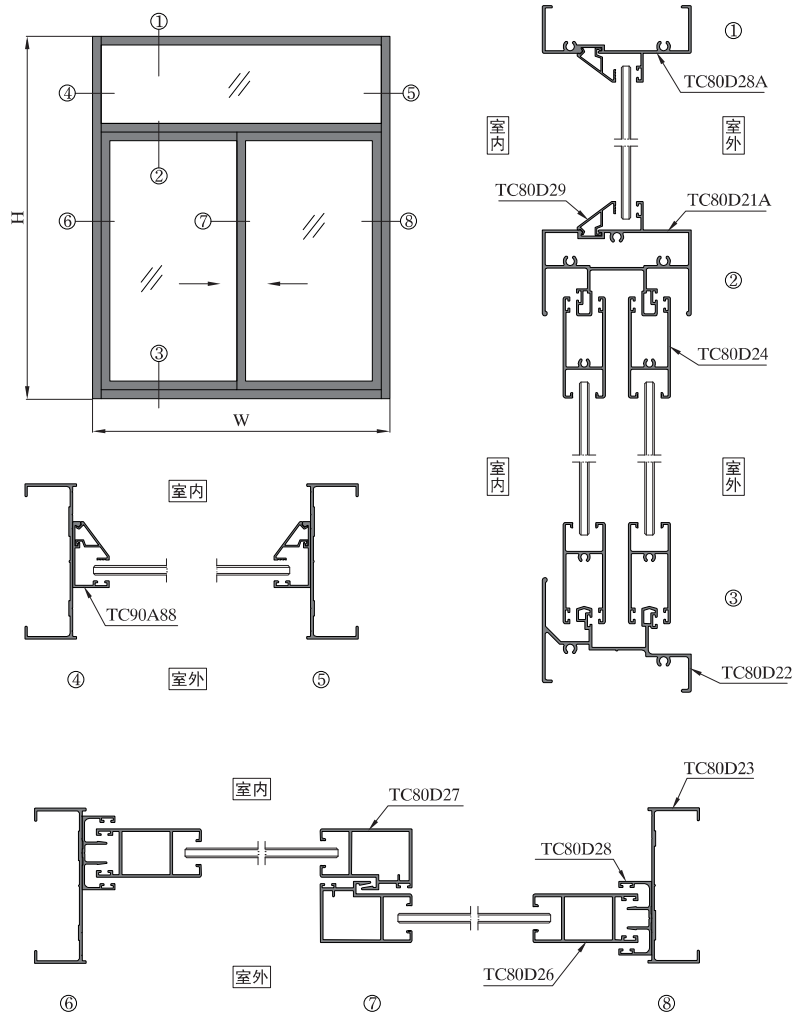

序号 S/N	型号理论重量 JMA Code & KG/M	型材图 Drawing	序号 S/N	型号理论重量 JMA Code & KG/M	型材图 Drawing	序号 S/N	型号理论重量 JMA Code & KG/M	型材图 Drawing
1	上滑 TC80D21 T=1.40 1.082kg/m		10	上固 TC80D28A T=1.40 0.741kg/m		19		
2	固上滑 TC80D21A T=1.40 1.599kg/m		11	压线 TC80D29 T=0.9 0.136kg/m		20		
3	下滑 TC80D22 T=1.40 1.107kg/m		12	压线 TC90A88 T=1.20 0.234kg/m		21		
4	固下滑 TC80D22A T=1.40 1.544kg/m		13			22		
5	边封 TC80D23 T=1.40 0.625kg/m		14			23		
6	上下方 TC80D24 T=1.40 0.583kg/m		15			24		
7	光企 TC80D26 T=1.40 0.714kg/m		16			25		
8	勾企 TC80D27 T=1.40 0.718kg/m		17			26		
9	轨道 TC80D28 T=1.20 0.364kg/m		18			27		

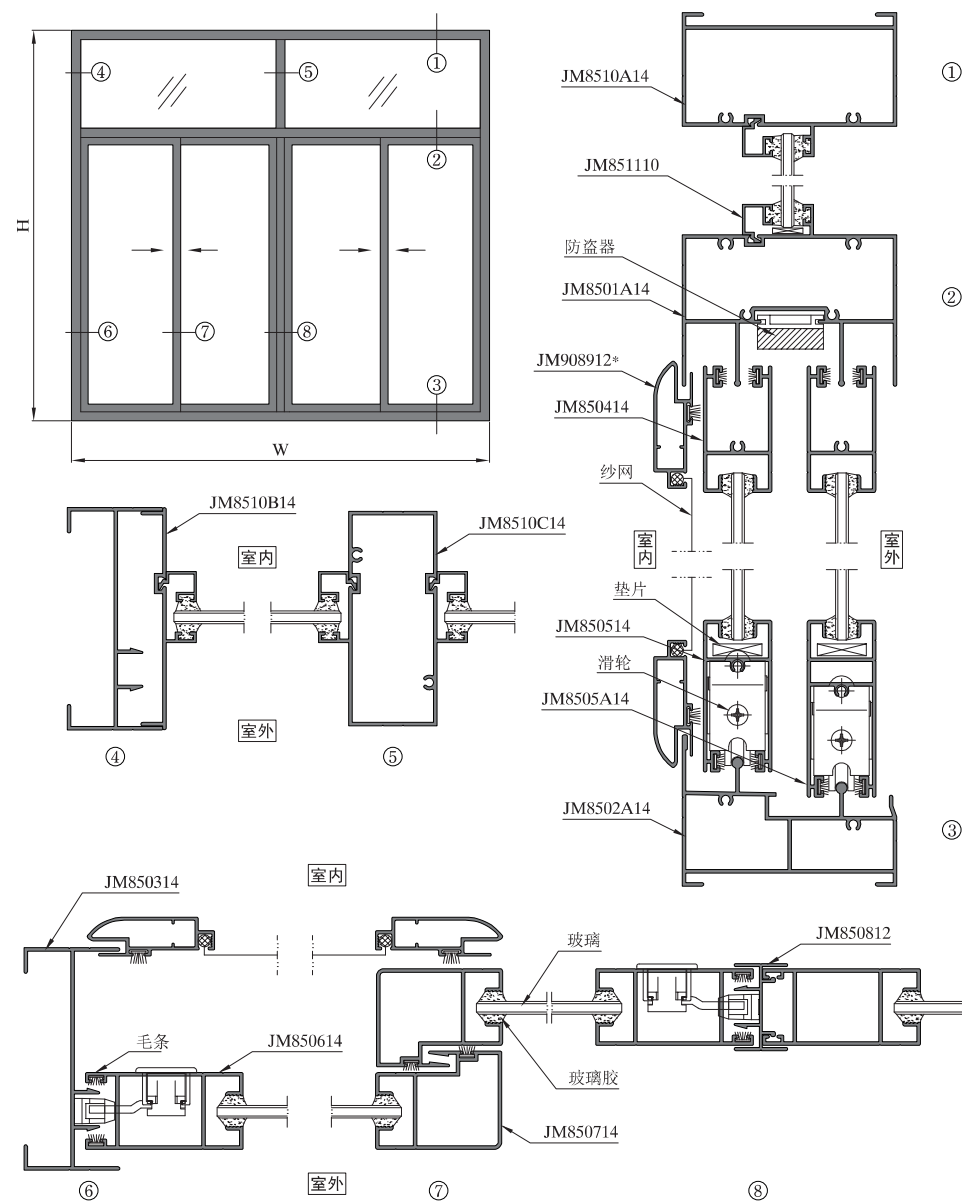
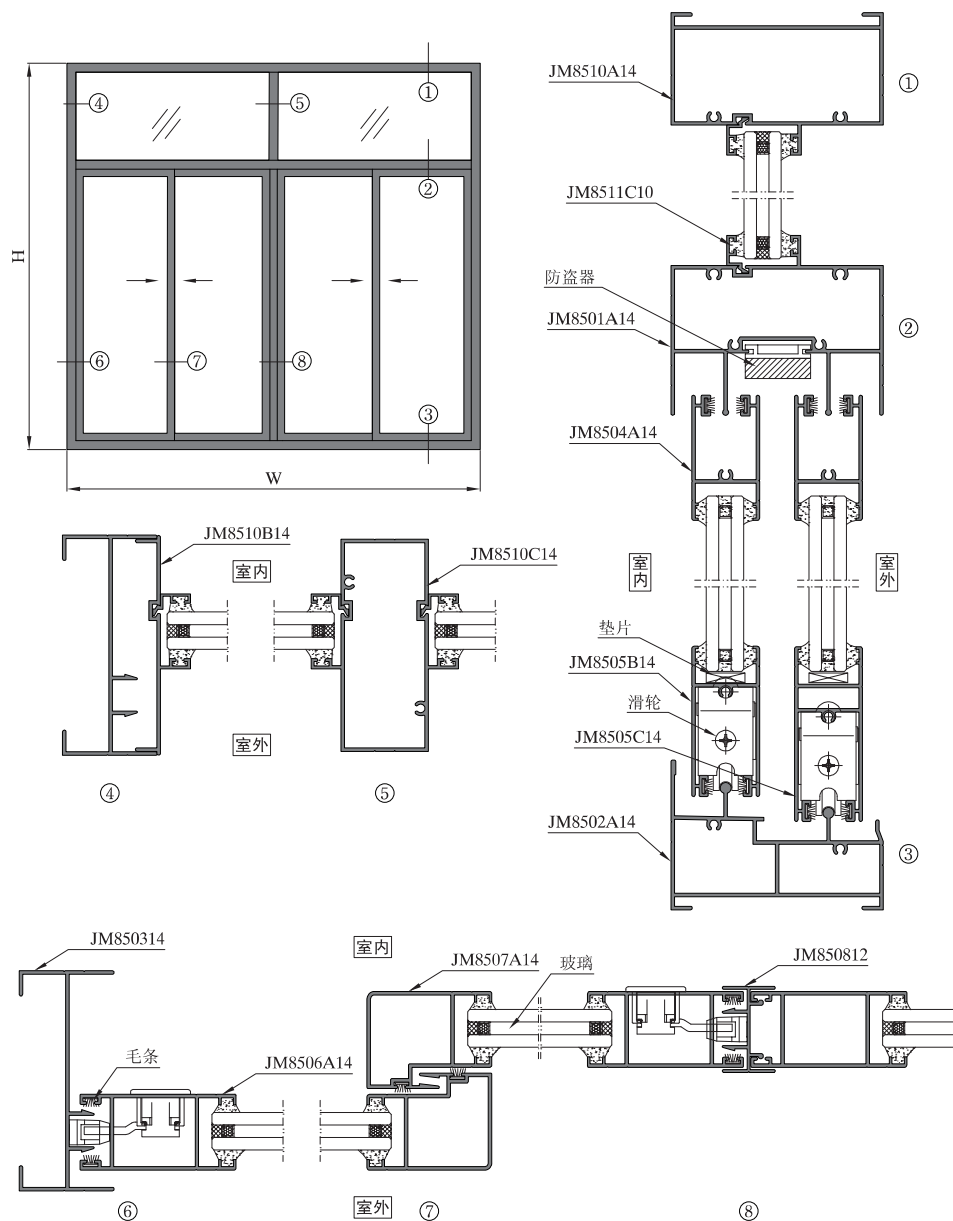

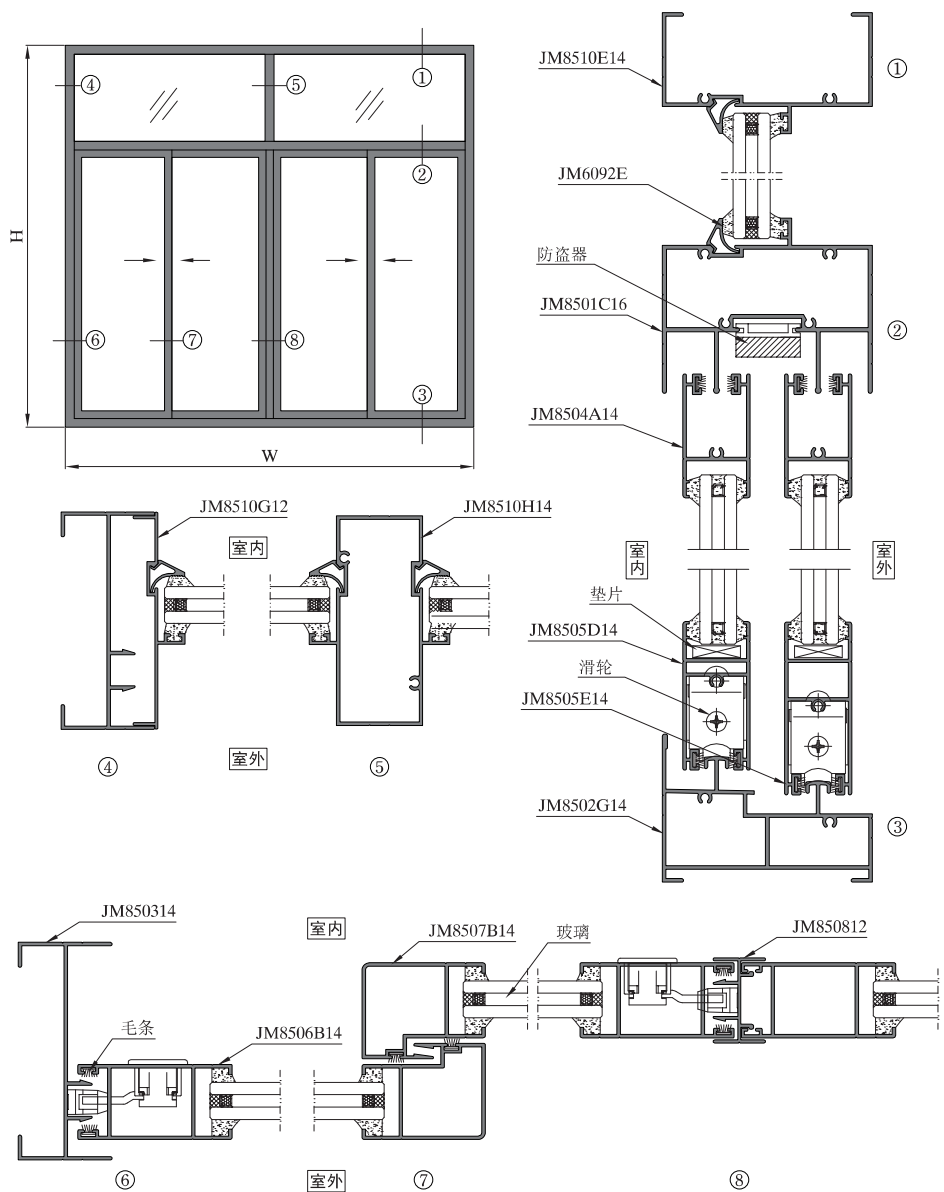

序号 S/N	型号理论重量 JMA Code & KG/M	型材图 Drawing	序号 S/N	型号理论重量 JMA Code & KG/M	型材图 Drawing	序号 S/N	型号理论重量 JMA Code & KG/M	型材图 Drawing
1	上滑 JM8501I14 1.024kg/m		10	下滑 JM8502G14 1.535kg/m		19	边封 JM8503A14 1.179kg/m	
2	固上滑 JM8501A14 1.643kg/m		11	固下滑 JM8502H14 1.663kg/m		20	双边封 JM8503B14 1.288kg/m	
3	上滑 JM8501B14 1.524kg/m		12	下滑 JM8502I14 1.17kg/m		21	上方 JM8504I4 0.765kg/m	
4	固上滑 JM8501C16 1.832kg/m		13	固下滑 JM8502L14 1.705kg/m		22	下方 JM8505I4 0.839kg/m	
5	固上滑 JM8501F14 1.675kg/m		14	下滑 JM8502M16 0.989kg/m		23	下方 JM8505A14 1.021kg/m	
6	下滑 JM8502I4 0.999kg/m		15	固下滑 JM8502V14 1.614kg/m		24	上方 JM8504A14 0.683kg/m	
7	下滑 JM8502A14 1.49kg/m		16	下滑 JM8502XA14 1.085kg/m		25	上方 JM8504K14 0.678kg/m	
8	下滑 JM8502B14 1.425kg/m		17	下滑 JM8502Z14 0.907kg/m		26	上方 JM8504K20 0.833kg/m	
9	固下滑 JM8502C14 1.632kg/m		18	边封 JM8503I4 0.812kg/m		27	上方 JM8505AA14 0.752kg/m	

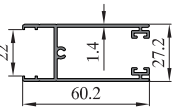
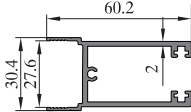
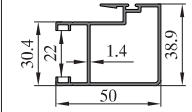
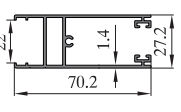
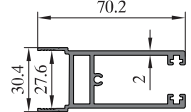
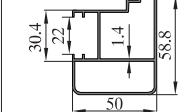
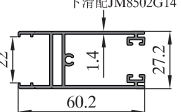
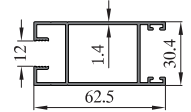
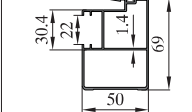
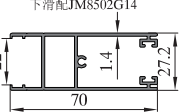
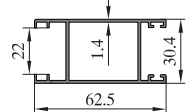
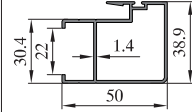
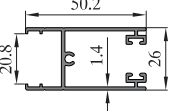
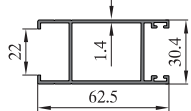
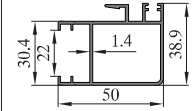
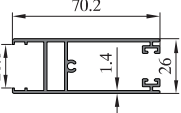
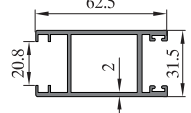
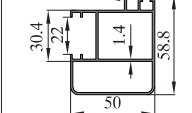
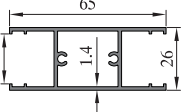
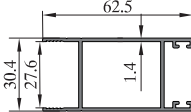
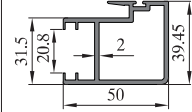
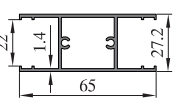
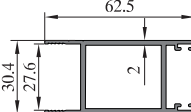
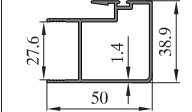
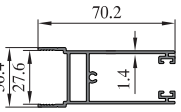
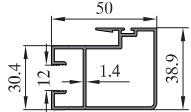
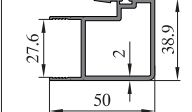

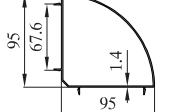
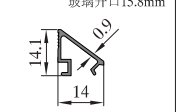
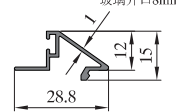
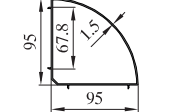
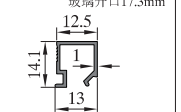
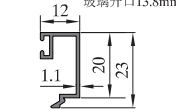
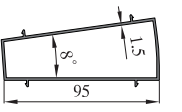
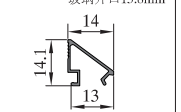
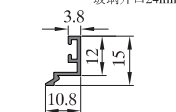
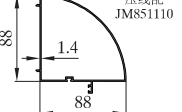
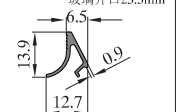
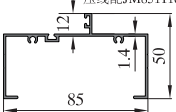
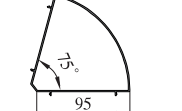
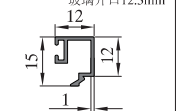
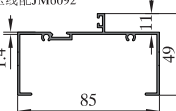
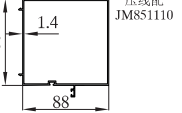
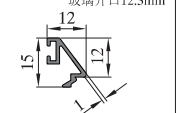
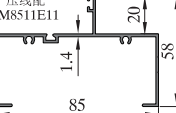
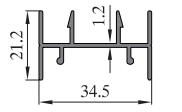
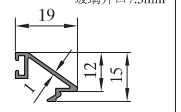
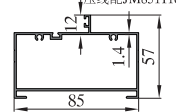
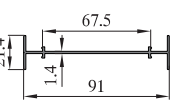
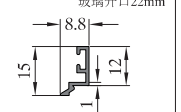
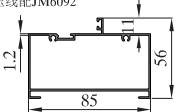
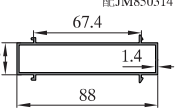
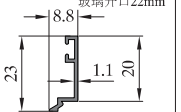
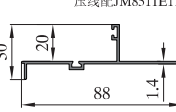
序号 S/N	型号理论重量 JMA Code & KG/M	型材图 Drawing	序号 S/N	型号理论重量 JMA Code & KG/M	型材图 Drawing	序号 S/N	型号理论重量 JMA Code & KG/M	型材图 Drawing
28	下方 JM8505B14 0.754kg/m		37	下方 JM8505AD20 0.94kg/m		46	勾企 JM8507A14 0.795kg/m	
29	下方 JM8505C14 0.934kg/m		38	下方 JM8505AF20 1.192kg/m		47	勾企 JM8507H14 1.142kg/m	
30	下方 JM8505D14 0.862kg/m	下滑配JM8502G14 	39	光企 JM850614 0.899kg/m		48	勾企 JM8507L14 1.252kg/m	
31	下方 JM8505E14 0.943kg/m	下滑配JM8502G14 	40	光企 JM8506A14 0.825kg/m		49	勾企 JM8507B14 0.78kg/m	
32	上方 JM8504C14 0.674kg/m		41	光企 JM8506B14 0.808kg/m		50	勾企 JM8507J14 0.812kg/m	
33	上方 JM8504G14 0.934kg/m		42	光企 JM8506F20 1.169kg/m		51	勾企 JM8507K14 1.155kg/m	
34	中横 JM8505N14 0.811kg/m		43	光企 JM8506R14 0.784kg/m		52	勾企 JM8507F20 1.104kg/m	
35	中横 JM8505K14 0.821kg/m		44	光企 JM8506R20 1.004kg/m		53	勾企 JM8507Y14 0.754kg/m	
36	下方 JM8505AB14 0.933kg/m		45	勾企 JM850714 0.868kg/m		54	勾企 JM8507Y20 0.988kg/m	

序号 S/N	型号理论重量 JMA Code & KG/M	型材图 Drawing	序号 S/N	型号理论重量 JMA Code & KG/M	型材图 Drawing	序号 S/N	型号理论重量 JMA Code & KG/M	型材图 Drawing
55	转角 JM850914 1.475kg/m		64	压线 JM6092 0.108kg/m	玻璃开口15.8mm 	73	压线 JM8511F10 0.18kg/m	玻璃开口8mm 
56	转角 JM8509C15 1.502kg/m		65	压线 JM6092C 0.13kg/m	玻璃开口17.3mm 	74	压线 JM8511G11 0.168kg/m	玻璃开口13.8mm 
57	转角 JM8509B15 1.146kg/m		66	压线 JM6092D 0.087kg/m	玻璃开口15.8mm 	75	压线 JM8511H10 0.098kg/m	玻璃开口24mm 
58	转角 JM8509G14 1.403kg/m	压线配 JM851110 	67	压线 JM6092E 0.097kg/m	玻璃开口23.3mm 	76	上固 JM851014 0.873kg/m	压线配JM851110 
59	转角 JM8509A15 1.51kg/m		68	压线 JM851110 0.132kg/m	玻璃开口12.3mm 	77	上固 JM8510E14 0.865kg/m	压线配JM6092 
60	转角 JM8509H14 1.556kg/m	压线配 JM851110 	69	压线 JM8511A10 0.117kg/m	玻璃开口12.3mm 	78	上固 JM8510K14 0.902kg/m	压线配 JM8511E11 
61	收口 JM850812 0.377kg/m		70	压线 JM8511B10 0.138kg/m	玻璃开口7.3mm 	79	上固 JM8510A14 1.273kg/m	压线配JM851110 
62	拼条 JM8508A14 0.586kg/m		71	压线 JM8511C10 0.092kg/m	玻璃开口22mm 	80	上固 JM8510F12 1.098kg/m	压线配JM6092 
63	拼管 JM8508B14 0.946kg/m	配JM850314 	72	压线 JM8511E11 0.12kg/m	玻璃开口22mm 	81	插板 JM8510L14 0.559kg/m	压线配JM8511E11 

图中所示型材截面、装配、编号、尺寸及重量仅供参考。如有疑问，请向本公司查询。
 Information above just for your reference. Please contact us if you have any questions, Thank you!

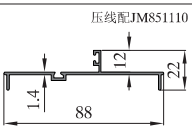
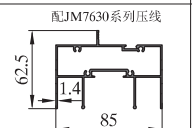
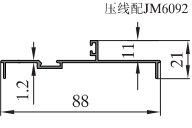
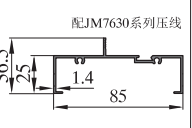
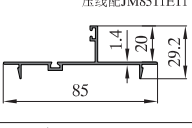
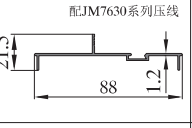
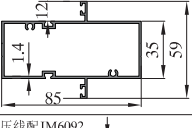
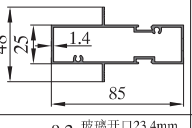
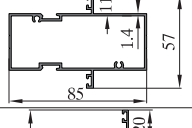
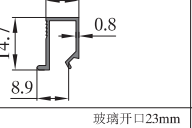
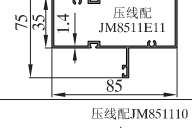
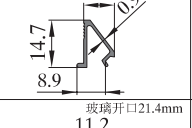
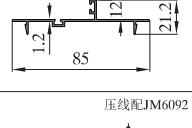
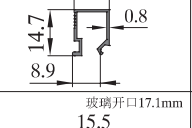
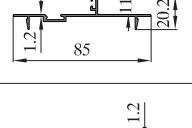
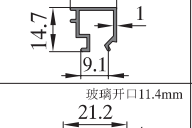
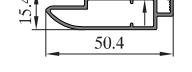
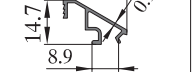
图中所示型材截面、装配、编号、尺寸及重量仅供参考。如有疑问，请向本公司查询。
 Information above just for your reference. Please contact us if you have any questions, Thank you!

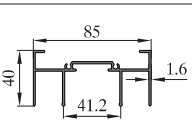
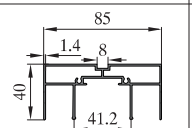
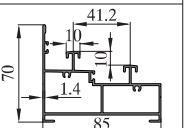
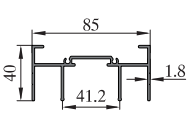
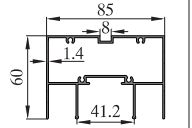
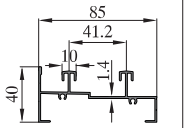
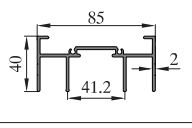
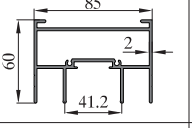
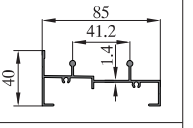
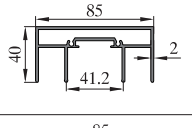
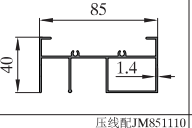
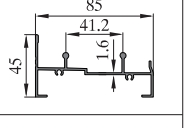
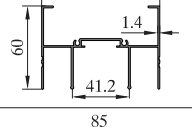
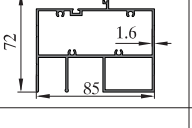
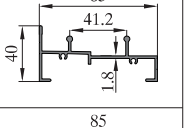
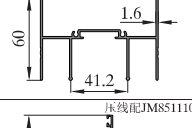
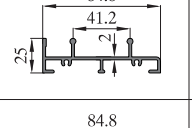
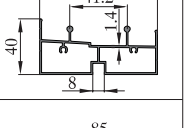
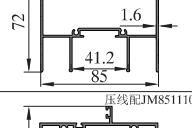
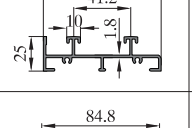
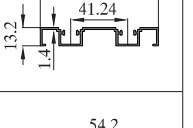
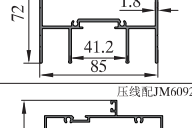
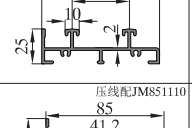
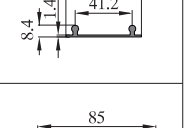
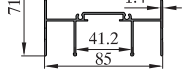
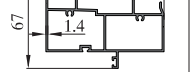







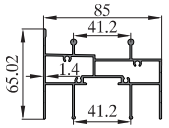
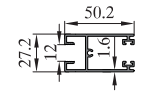
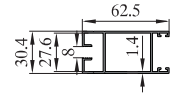
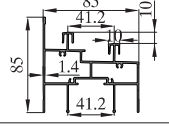
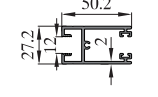
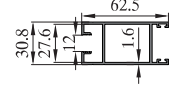
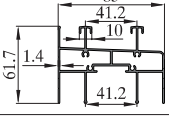
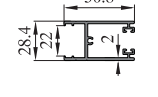
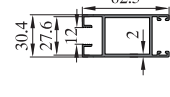
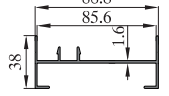
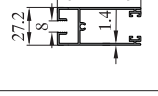
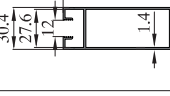
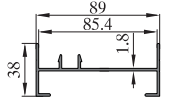
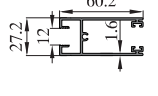
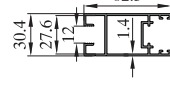
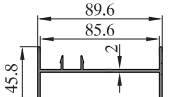
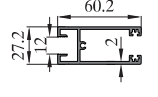
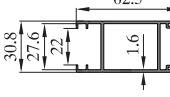
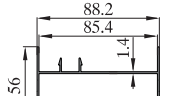
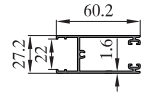
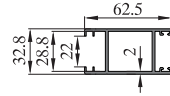
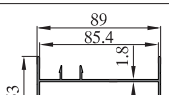
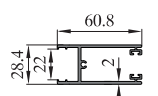
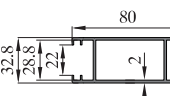
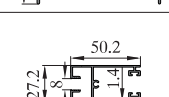
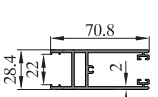
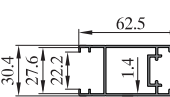

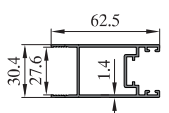
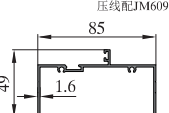

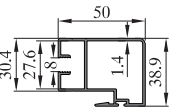
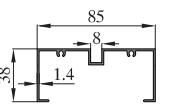

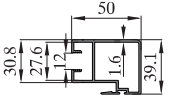
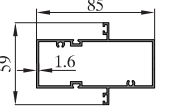

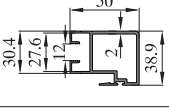
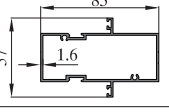

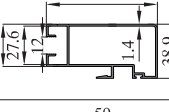
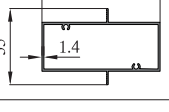
序号 S/N	型号理论重量 JMA Code & KG/M	型材图 Drawing	序号 S/N	型号理论重量 JMA Code & KG/M	型材图 Drawing	序号 S/N	型号理论重量 JMA Code & KG/M	型材图 Drawing
82	插板 JM8510B14 0.536kg/m		91	固上滑 JM8501P14 1.535kg/m		100		
83	插板 JM8510G12 0.474kg/m		92	固定框 JM8510QA14 0.710kg/m		101		
84	插板 JM8510M14 0.539kg/m		93	边封插板 JM8510GA12* 0.434kg/m		102		
85	中柱 JM8510C14 1.239kg/m		94	固定框 JM8510RA14 1.096kg/m		103		
86	中柱 JM8510H14 1.234kg/m		95	压线 JM7630ZC 0.109kg/m		104		
87	中柱 JM8510N14 1.298kg/m		96	压线 JM7630L09 0.103kg/m		105		
88	插板 JM8510D12 0.461kg/m		97	压线 JM7630T08 0.111kg/m		106		
89	插板 JM8510J12 0.464kg/m		98	压线 JM7630I0 0.154kg/m		107		
90	纱窗 JM908912* 0.482kg/m		99	压线 JM7630J09 0.143kg/m		108		

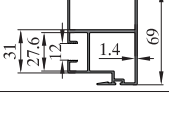
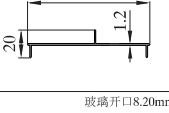
序号 S/N	型号理论重量 JMA Code & KG/M	型材图 Drawing	序号 S/N	型号理论重量 JMA Code & KG/M	型材图 Drawing	序号 S/N	型号理论重量 JMA Code & KG/M	型材图 Drawing
1	上滑 JM8501I16 T=1.60 1.157kg/m		10	固上滑 JM8501AB14 T=1.4 1.339kg/m		19	下滑 JM8502AL T=1.4 1.598kg/m	
2	上滑 JM8501I18 T=1.80 1.284kg/m		11	固上滑 JM8501CA14 T=1.4 1.577kg/m		20	下滑 JM8502AP T=1.4 0.999kg/m	
3	上滑 JM8501DG T=2.0 1.403kg/m		12	上滑 JM8501B20 T=2.0 2.117kg/m		21	下滑 JM8502M14 T=1.4 0.887kg/m	
4	上滑 JM8501K20 T=2.0 1.778kg/m		13	单轨上滑 JM8501W14 T=1.4 1.131kg/m		22	下滑 JM8502ZT T=1.6 1.010kg/m	
5	上滑 JM8501ZA T=1.4 1.218kg/m		14	单轨上滑 JM8501X16 T=1.6 1.960kg/m		23	下滑 JM8502M18 T=1.8 1.084kg/m	
6	上滑 JM8501ZB T=1.6 1.360kg/m		15	下滑 JM8502TC T=2.0 1.138kg/m		24	固下滑 JM8502MQ T=1.4 1.311kg/m	
7	固上滑 JM8501A16 T=1.6 1.835kg/m		16	下滑 JM8502Z18 T=1.8 1.138kg/m		25	下滑 JM8502AT T=1.4 0.734kg/m	
8	固上滑 JM8501A18 T=1.8 2.028kg/m		17	下滑 JM8502Z20 T=2.0 1.251kg/m		26	下滑 JM8502KE T=1.4 0.375kg/m	
9	固上滑 JM8501C14 T=1.4 1.623kg/m		18	固下滑 JM8502BA14 T=1.4 1.503kg/m		27	单轨下滑 JM8502ZB14 T=1.4 0.809kg/m	

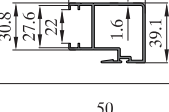
图中所示型材截面、装配、编号、尺寸及重量仅供参考。如有疑问，请向本公司查询。
 Information above just for your reference. Please contact us if you have any questions, Thank you!

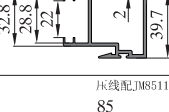
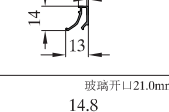
图中所示型材截面、装配、编号、尺寸及重量仅供参考。如有疑问，请向本公司查询。
 Information above just for your reference. Please contact us if you have any questions, Thank you!

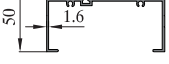
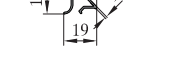
序号 S/N	型号理论重量 JMA Code & KG/M	型材图 Drawing	序号 S/N	型号理论重量 JMA Code & KG/M	型材图 Drawing	序号 S/N	型号理论重量 JMA Code & KG/M	型材图 Drawing
28	上下滑 JM8502BK T=1.4 1.709kg/m		37	上方 JM850416 T=1.6 0.837kg/m		46	光企 JM8506ZC T=1.4 0.915kg/m	
29	上下滑 JM8502RH T=1.4 1.977kg/m		38	上方 JM850420 T=2.0 0.986kg/m		47	光企 JM850616 T=1.6 1.004kg/m	
30	上下滑 JM8502TA T=1.4 1.780kg/m		39	上方 JM8504A20 T=2.0 0.908kg/m		48	光企 JM850620 T=2.0 1.108kg/m	
31	边封 JM850316 T=1.6 0.932kg/m		40	下方 JM8505ZJ T=1.4 0.855kg/m		49	光企 JM8506W14 T=1.4 1.124kg/m	
32	边封 JM850318 T=1.8 1.043kg/m		41	下方 JM850516 T=1.6 0.915kg/m		50	光企 JM8506ZA T=1.4 0.974kg/m	
33	边封 JM8503A20 T=2.0 1.716kg/m		42	下方 JM8505U20 T=2.0 1.091kg/m		51	光企 JM8506A16 T=1.6 0.930kg/m	
34	边封 JM8503AG14 T=1.4 1.322kg/m		43	下方 JM8505B16 T=1.6 0.831kg/m		52	光企 JM8506A20 T=2.0 1.162kg/m	
35	双边封 JM8503B18 T=1.8 1.612kg/m		44	下方 JM8505B20 T=2.0 1.014kg/m		53	光企 JM8506AC T=2.0 1.367kg/m	
36	上方 JM8504R T=1.4 0.782kg/m		45	下方 JM8505C20 T=2.0 1.273kg/m		54	光企 JM8506ZB T=1.4 0.899kg/m	

序号 S/N	型号理论重量 JMA Code & KG/M	型材图 Drawing	序号 S/N	型号理论重量 JMA Code & KG/M	型材图 Drawing	序号 S/N	型号理论重量 JMA Code & KG/M	型材图 Drawing
55	光企 JM8506G14 T=1.4 0.858kg/m		64	上固 JM8510E16 T=1.6 0.959kg/m		73	压线配JM6092	
56	勾企 JM8507ZD T=1.4 0.885kg/m		65	上固 JM8510ZG14 T=1.4 0.859kg/m		74		
57	勾企 JM850716 T=1.6 0.975kg/m		66	中柱 JM8510C16 T=1.6 1.380kg/m		75	压线配JM851110	
58	勾企 JM850720 T=2.0 1.106kg/m		67	中柱 JM8510H16 T=1.6 1.371kg/m		76	压线配JM6092	
59	勾企 JM8507AC14 T=1.4 1.152kg/m		68	中柱 JM8510CA14 T=1.4 1.084kg/m		77		
60	勾企 JM8507P14 T=1.4 1.394kg/m		69	插板 JM8510BA12 T=1.2 0.401kg/m		78		
61	勾企 JM8507A16 T=1.6 0.893kg/m		70	压线 JM6092B T=0.9 0.140kg/m		79	玻璃开口8.20mm	
62	勾企 JM8507A20 T=2.0 1.119kg/m		71	压线 JM6092K T=0.9 0.103kg/m		80	玻璃开口24.0mm	
63	上固 JM851016 T=1.6 0.975kg/m		72	压线 JM6092M T=1.0 0.151kg/m		81	玻璃开口121.0mm	

图中所示型材截面、装配、编号、尺寸及重量仅供参考。如有疑问，请向本公司查询。
 Information above just for your reference. Please contact us if you have any questions, Thank you!

图中所示型材截面、装配、编号、尺寸及重量仅供参考。如有疑问，请向本公司查询。
 Information above just for your reference. Please contact us if you have any questions, Thank you!

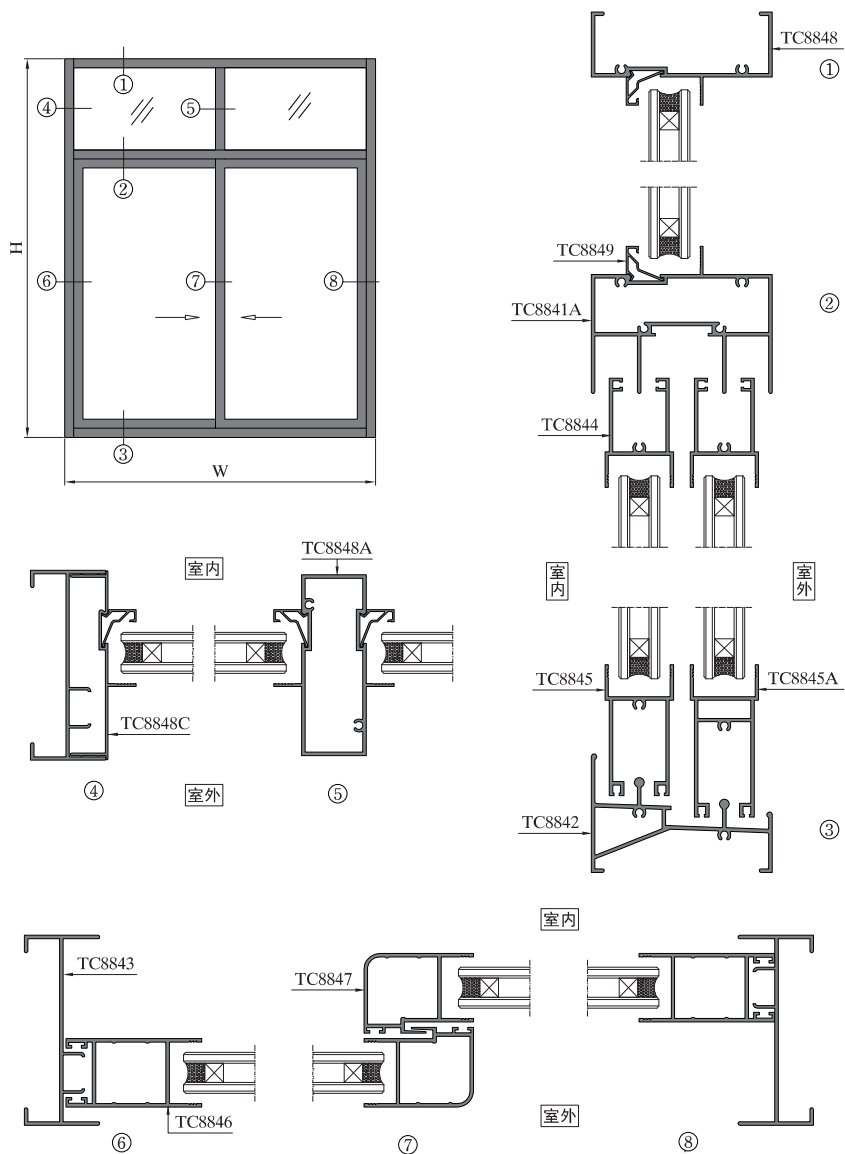

序号 S/N	型号理论重量 JMA Code & KG/M	型材图 Drawing	序号 S/N	型号理论重量 JMA Code & KG/M	型材图 Drawing	序号 S/N	型号理论重量 JMA Code & KG/M	型材图 Drawing
1	上滑 TC8841 1.143kg/m		10	光企 TC8847 0.827kg/m		19	下滑 TC8842D 1.405kg/m	
2	固上滑 TC8841A 1.769kg/m		11	上固 TC8848 0.846kg/m		20	固下滑 TC8842C 1.709kg/m	
3	下滑 TC8842 1.265kg/m		12	中柱 TC8848A 1.270kg/m		21	压线 TC8849E 0.108kg/m	
4	固下滑 TC8842B 1.638kg/m		13	收口 TC8848B 0.310kg/m				
5	边封 TC8843 0.855kg/m		14	边封插板 TC8848C 0.500kg/m				
6	上方 TC8844 0.710kg/m		15	压线 TC8849 0.114kg/m				
7	下方 TC8845 0.834kg/m		16	转角 TC8849B 1.500kg/m				
8	下方 TC8845A 1.043kg/m		17	工字 TC8849D 0.710kg/m				
9	光企 TC8846 0.931kg/m		18	下滑 TC8842A 1.335kg/m				

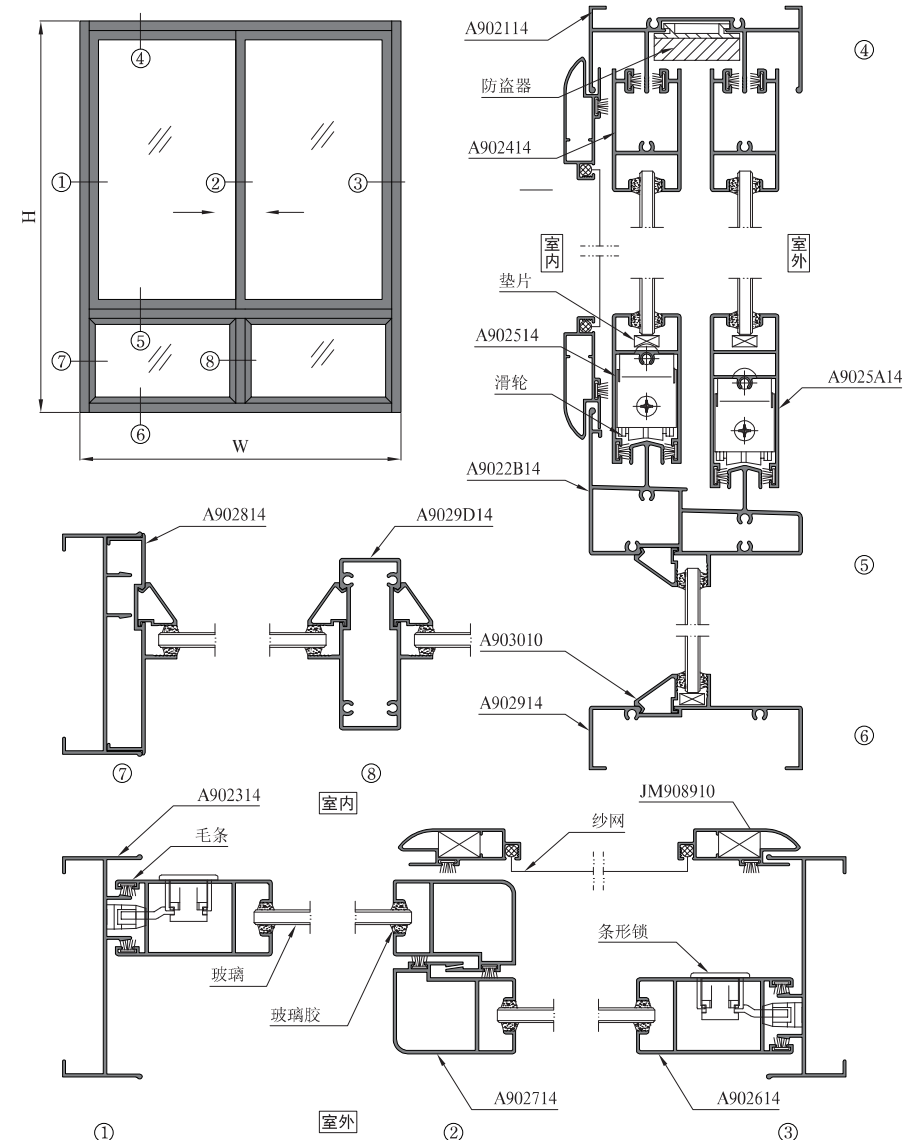
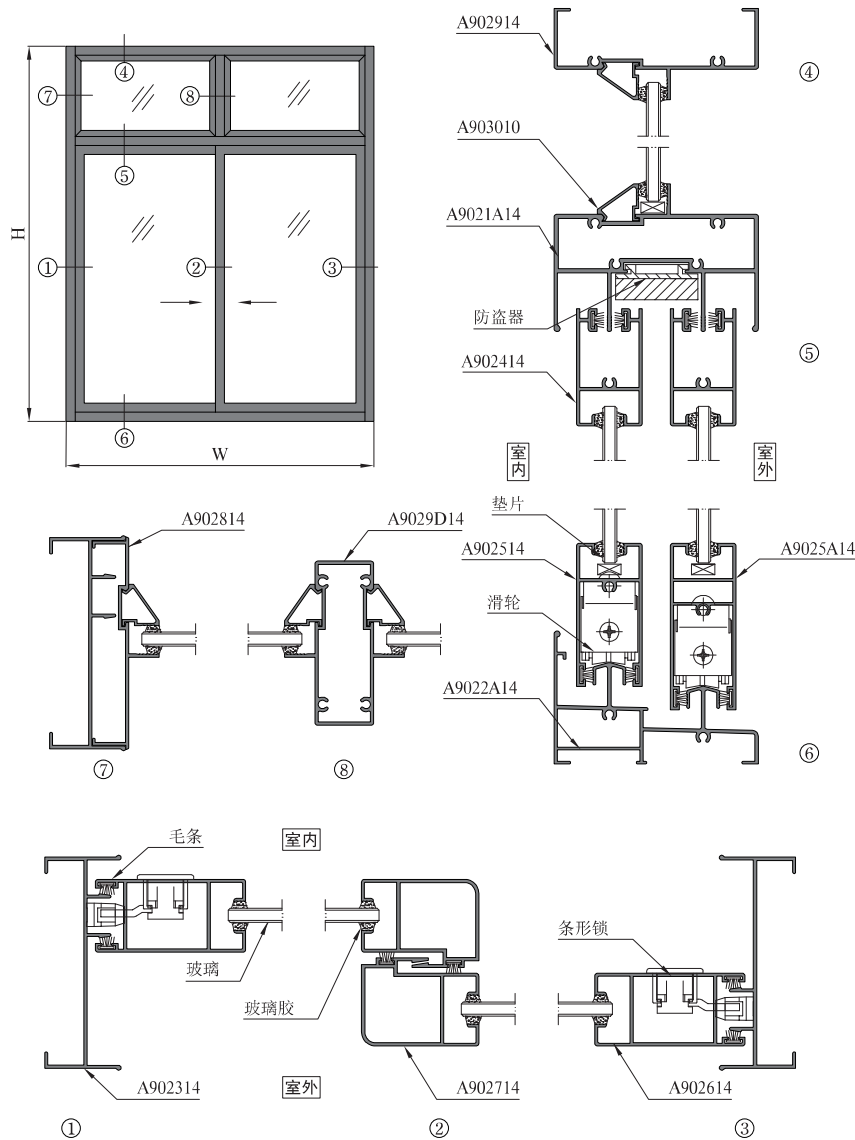

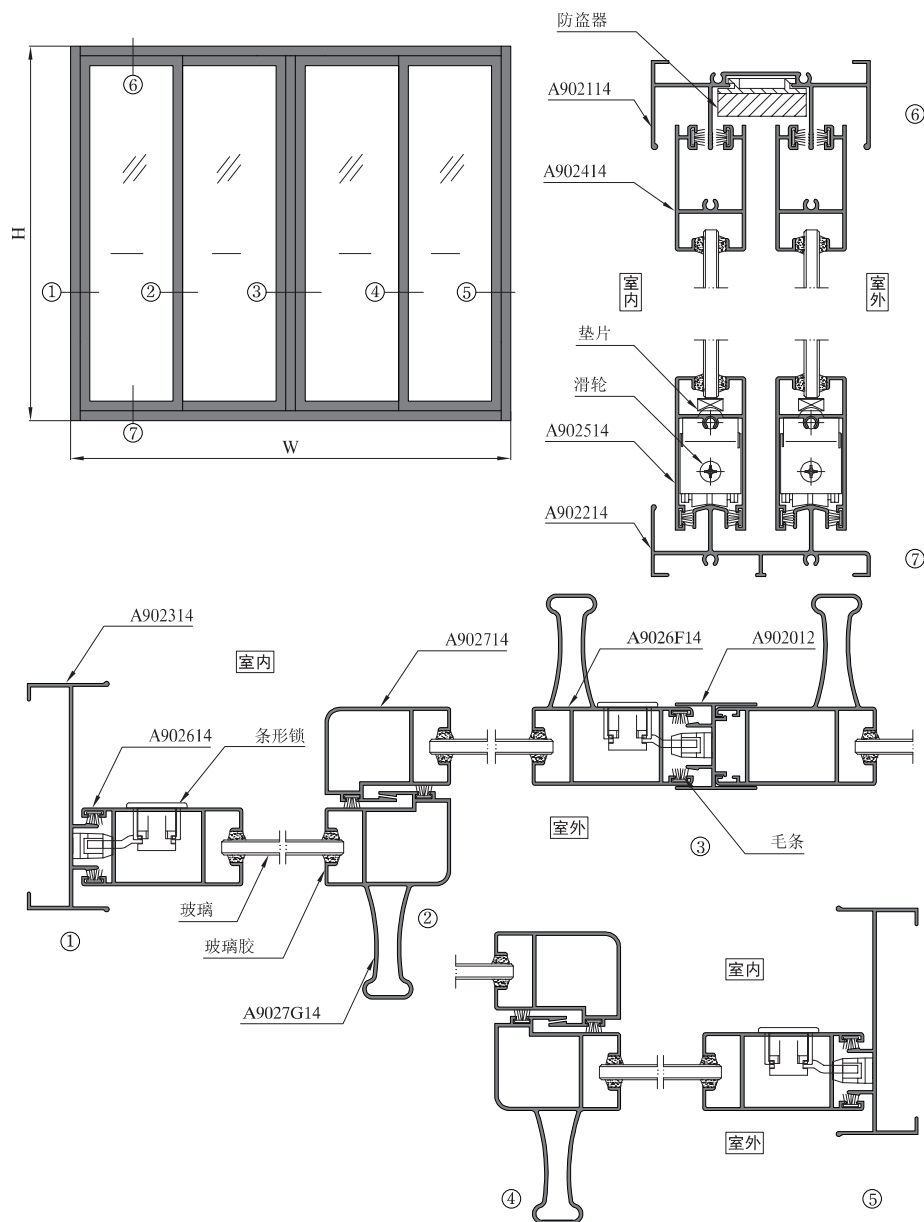

序号 S/N	型号理论重量 JMA Code & KG/M	型材图 Drawing	序号 S/N	型号理论重量 JMA Code & KG/M	型材图 Drawing	序号 S/N	型号理论重量 JMA Code & KG/M	型材图 Drawing
1	上滑 A902114 0.987kg/m		10	下滑 A9022C14 1.134kg/m		19	下方 A9025A14 0.929kg/m	
2	上滑 A902120 1.337kg/m		11	边封 A902314 0.731kg/m		20	下方 A9025B20 0.901kg/m	
3	固上滑 A9021A18 1.807kg/m		12	边封 A902320 1.038kg/m		21	下方 A9025C20 1.015kg/m	
4	固上滑 A9021B20 2.101kg/m		13	上方 A902414 0.766kg/m		22	下方 A9025K14 0.839kg/m	
5	固上滑 A9021A14 1.556kg/m		14	上方 A9024A20 0.903kg/m		23	下方 A9025J20 0.913kg/m	
6	下滑 A902214 0.963kg/m		15	上方 A9024B20 1.017kg/m		24	下方 A9025I14 0.684kg/m	
7	下滑 A902220 1.363kg/m		16	上方 A9024E20 0.915kg/m		25	光企 A902614 0.859kg/m	
8	下滑 A9022A14 1.314kg/m		17	上方 A9024E14 0.684kg/m		26	光企 A9026A20 1.142kg/m	
9	固下滑 A9022B14 1.653kg/m		18	下方 A902514 0.766kg/m		27	光企 A9026B20 1.228kg/m	

图中所示型材截面、装配、编号、尺寸及重量仅供参考。如有疑问，请向本公司查询。
Information above just for your reference. Please contact us if you have any questions, Thank you!

图中所示型材截面、装配、编号、尺寸及重量仅供参考。如有疑问，请向本公司查询。
Information above just for your reference. Please contact us if you have any questions, Thank you!

序号 S/N	型号理论重量 JMA Code & KG/M	型材图 Drawing	序号 S/N	型号理论重量 JMA Code & KG/M	型材图 Drawing	序号 S/N	型号理论重量 JMA Code & KG/M	型材图 Drawing
28	光企 A9026F14 1.302kg/m		37	勾企 A9027Q20 1.014kg/m		46	上固定 A9029C14 1.048kg/m	
29	光企 A9026N14 0.767kg/m		38	勾企 A9027QA20 1.646kg/m		47	中柱 A9029D14 1.041kg/m	
30	光企 A9026N20 1.099kg/m		39	插板 A902814 0.567kg/m		48	转角 A9029SA 1.672kg/m	
31	勾企 A902714 0.809kg/m		40	插板 A902820 0.780kg/m		49	收口 A902012 0.473kg/m	
32	勾企 A9027A20 1.057kg/m		41	插板 A9028A20 0.660kg/m		50	收口 A9020A14 0.522kg/m	
33	勾企 A9027B20 1.144kg/m		42	上固定 A902914 0.741kg/m		51	收口 A9020F 0.253kg/m	
34	勾企 A9027C20 1.689kg/m		43	上固定 A902920 0.986kg/m		52	压线 A903010 0.134kg/m	 玻璃开口12mm
35	勾企 A9027G14 1.257kg/m		44	中柱 A9029A20 1.570kg/m		53	压线 A9030A10 0.116kg/m	 玻璃开口24mm
36	勾企 A9027Q14 0.718kg/m		45	插板 A9029B14 0.522kg/m		54	压线 A9030D10 0.102kg/m	 玻璃开口28.3mm

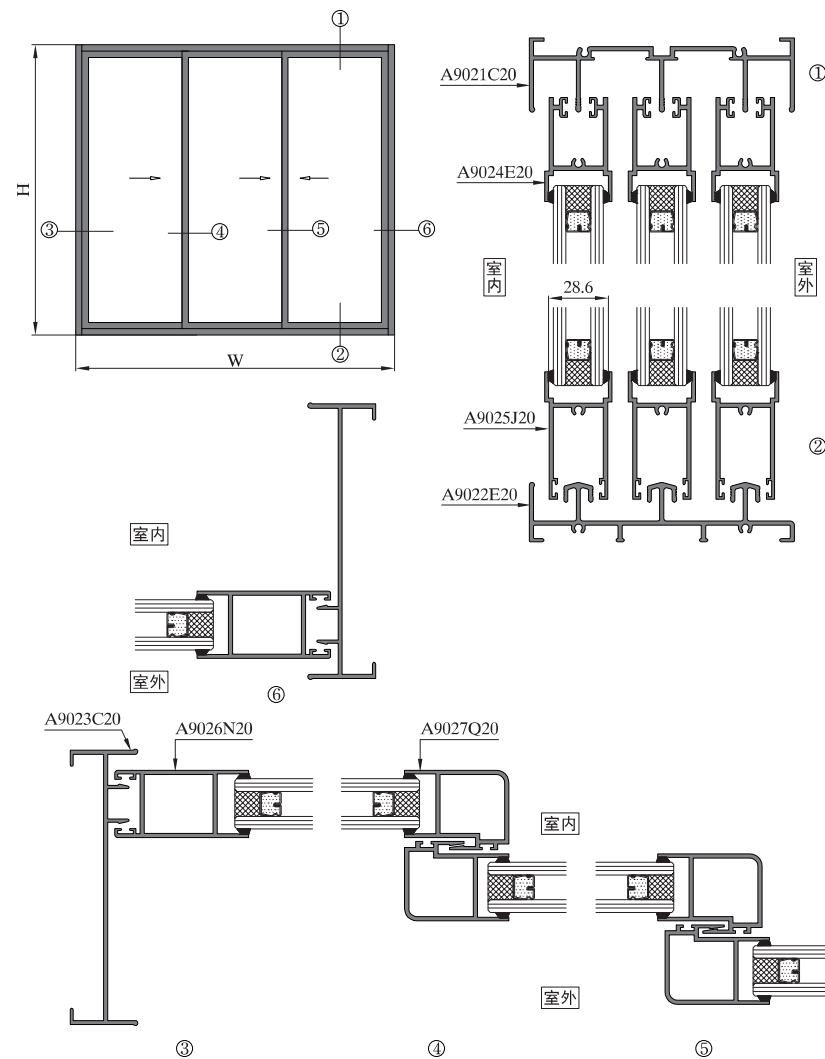

图中所示型材截面、装配、编号、尺寸及重量仅供参考。如有疑问，请向本公司查询。
Information above just for your reference. Please contact us if you have any questions, Thank you!

图中所示型材截面、装配、编号、尺寸及重量仅供参考。如有疑问，请向本公司查询。
Information above just for your reference. Please contact us if you have any questions, Thank you!

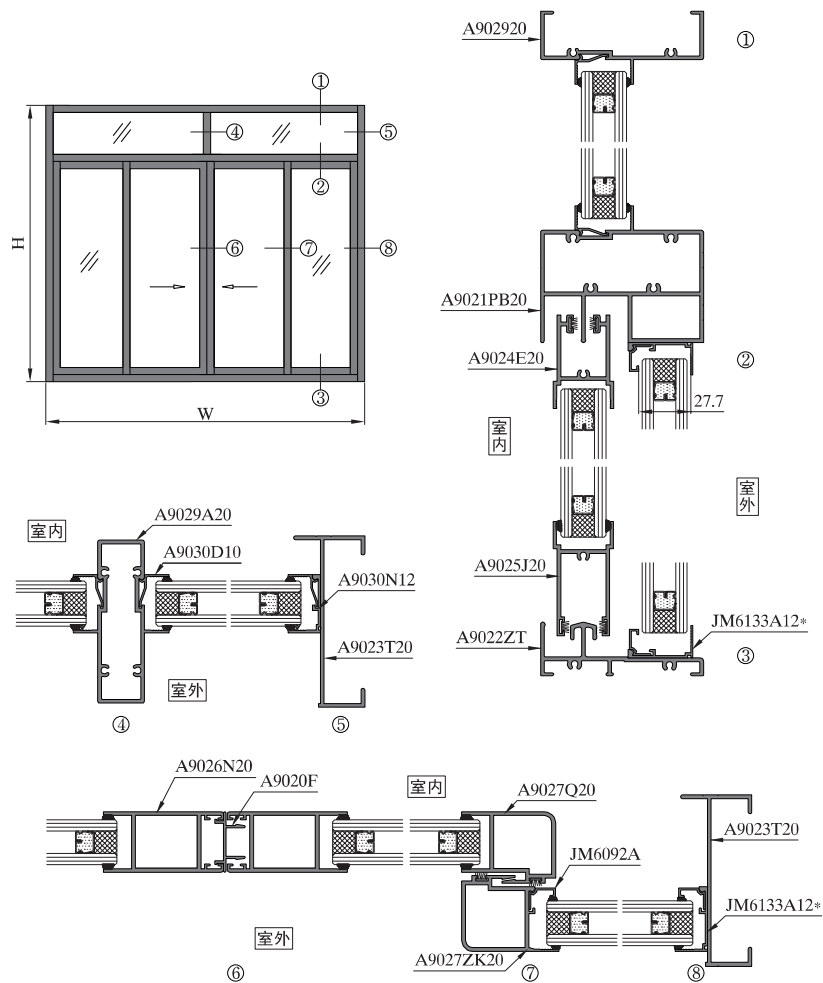

序号 S/N	型号理论重量 JMA Code & KG/M	型材图 Drawing	序号 S/N	型号理论重量 JMA Code & KG/M	型材图 Drawing	序号 S/N	型号理论重量 JMA Code & KG/M	型材图 Drawing
1	上滑 A9021C20 1.784kg/m		10	压座 A9030N12 0.218kg/m		19		
2	上滑 A9021PA20 1.642kg/m		11	压线 JM6092H 0.094kg/m		20		
3	固上滑 A9021PB20 2.473kg/m		12	压线 JM6092P 0.077kg/m		21		
4	下滑 A9022E20 1.899kg/m		13	压线 JM6092A 0.091kg/m		22		
5	下滑 A9022ZT 1.166kg/m		14	压线 A9030A10 0.116kg/m		23		
6	边封 A9023C20 1.271kg/m		15	压线 A9030D10 0.102kg/m		24		
7	边封 A9023T20 0.969kg/m		16	压线 A9030TB 0.104kg/m		25		
8	勾企 A9027ZK20 0.993kg/m		17	上固定 A902920 0.986kg/m		26		
9	压座 JM6133A12* 0.218kg/m		18			27		

图中所示型材截面、装配、编号、尺寸及重量仅供参考。如有疑问，请向本公司查询。
Information above just for your reference. Please contact us if you have any questions, Thank you!

图中所示型材截面、装配、编号、尺寸及重量仅供参考。如有疑问，请向本公司查询。
Information above just for your reference. Please contact us if you have any questions, Thank you!

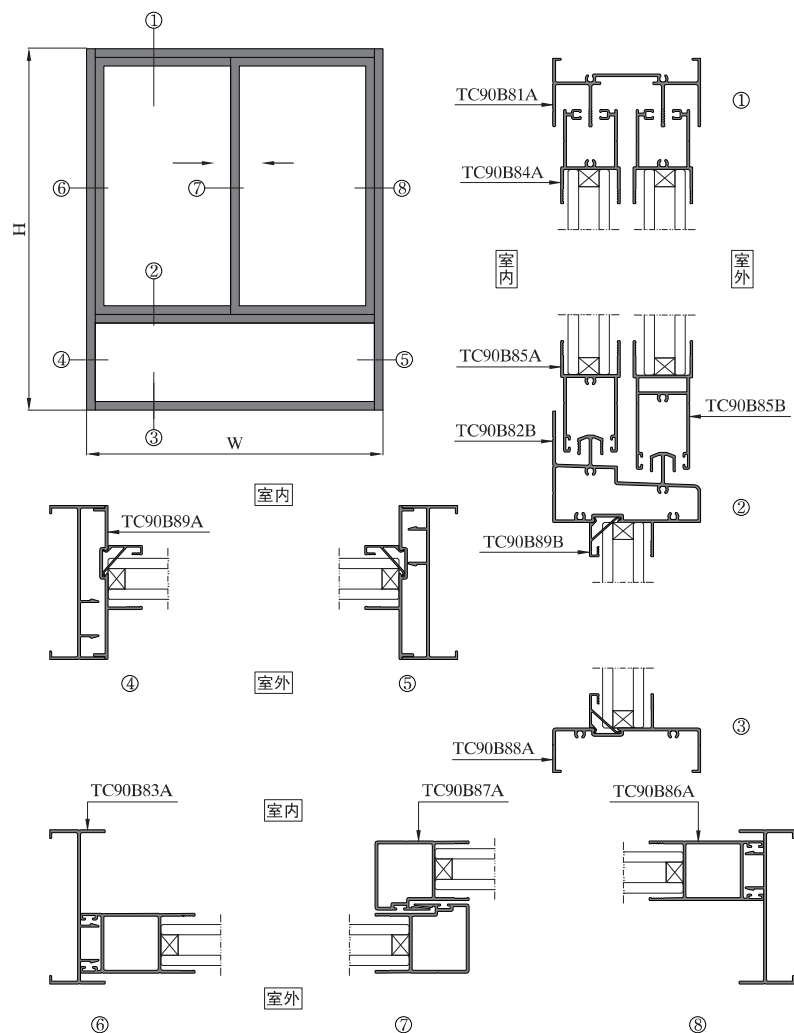

序号 S/N	型号理论重量 JMA Code & KG/M	型材图 Drawing	序号 S/N	型号理论重量 JMA Code & KG/M	型材图 Drawing	序号 S/N	型号理论重量 JMA Code & KG/M	型材图 Drawing
1	上滑 TC90B81A 1.121kg/m		10	下方 TC90B85B 1.041kg/m		19	压线 TC90B89B 0.152kg/m	
2	下滑 TC90B82A 1.336kg/m		11	下方 TC90B85D 1.118kg/m		20	压线 TC90B89D 0.202kg/m	
3	固下滑 TC90B82B 1.908kg/m		12	光企 TC90B86A 0.947kg/m		21	转角 TC90B88D 1.572kg/m	
4	边封 TC90B83A 0.821kg/m		13	光企 TC90B86B 1.055kg/m		22	转角 TC90B88C 2.022kg/m	
5	边封 TC90B83B 1.470kg/m		14	勾企 TC90B87A 0.922kg/m		23	固上滑 TC90B81B 1.784kg/m	
6	上方 TC90B84A 0.813kg/m		15	勾企 TC90B87B 1.030kg/m		24		
7	上方 TC90B84B 0.888kg/m		16	固定框 TC90B88A 0.850kg/m		25		
8	下方 TC90B85A 0.819kg/m		17	固定框 TC90B89C 1.325kg/m		26		
9	下方 TC90B85C 0.892kg/m		18	边封插板 TC90B89A 0.604kg/m		27		

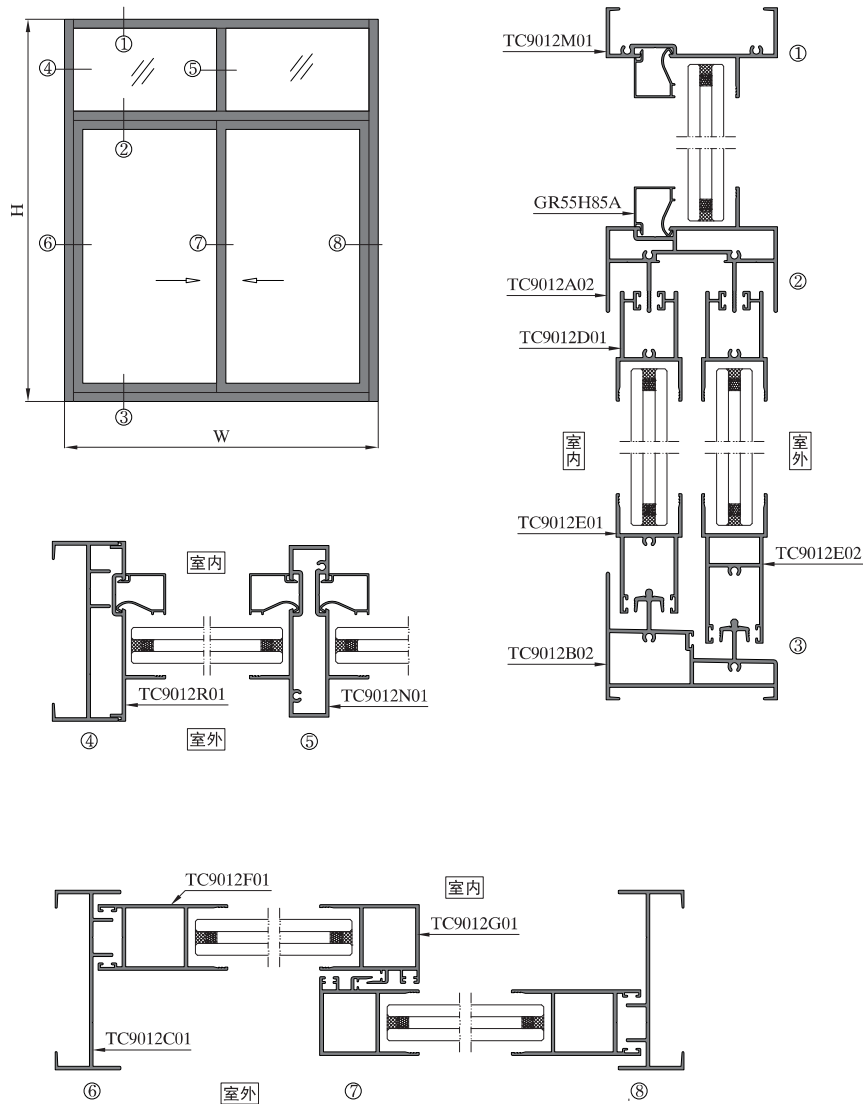

序号 S/N	型号理论重量 JMA Code & KG/M	型材图 Drawing	序号 S/N	型号理论重量 JMA Code & KG/M	型材图 Drawing	序号 S/N	型号理论重量 JMA Code & KG/M	型材图 Drawing
1	上滑 TC9012A01 1.241kg/m		10	光企 TC9012F01 1.000kg/m		19		
2	固定上滑 TC9012A02 1.867kg/m		11	光企 TC9012F02 1.071kg/m		20		
3	下滑 TC9012B01 1.284kg/m		12	勾企 TC9012G01 0.943kg/m		21		
4	下滑 TC9012B02 2.044kg/m		13	上固 TC9012M01 0.973kg/m		22		
5	固定下滑 TC9012B03 2.208kg/m		14	中柱 TC9012N01 1.494kg/m		23		
6	边封 TC9012C01 0.941kg/m		15	边封插板 TC9012R01 0.699kg/m		24		
7	上方 TC9012D01 0.913kg/m		16	收口 TC9012H01 0.203kg/m		25		
8	下方 TC9012E01 0.831kg/m		17	压线 GR55H85A 0.206kg/m		26		
9	下方 TC9012E02 1.121kg/m		18			27		

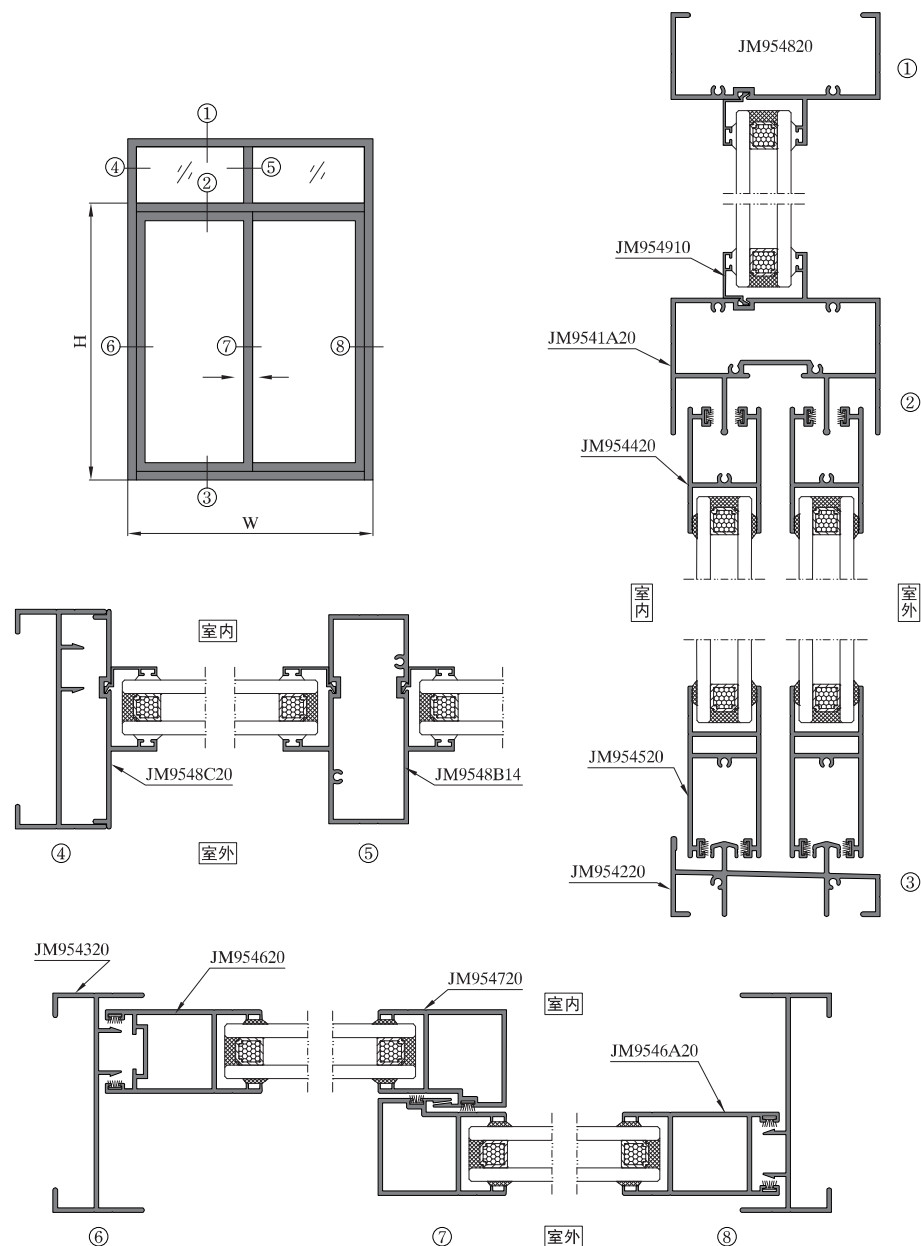
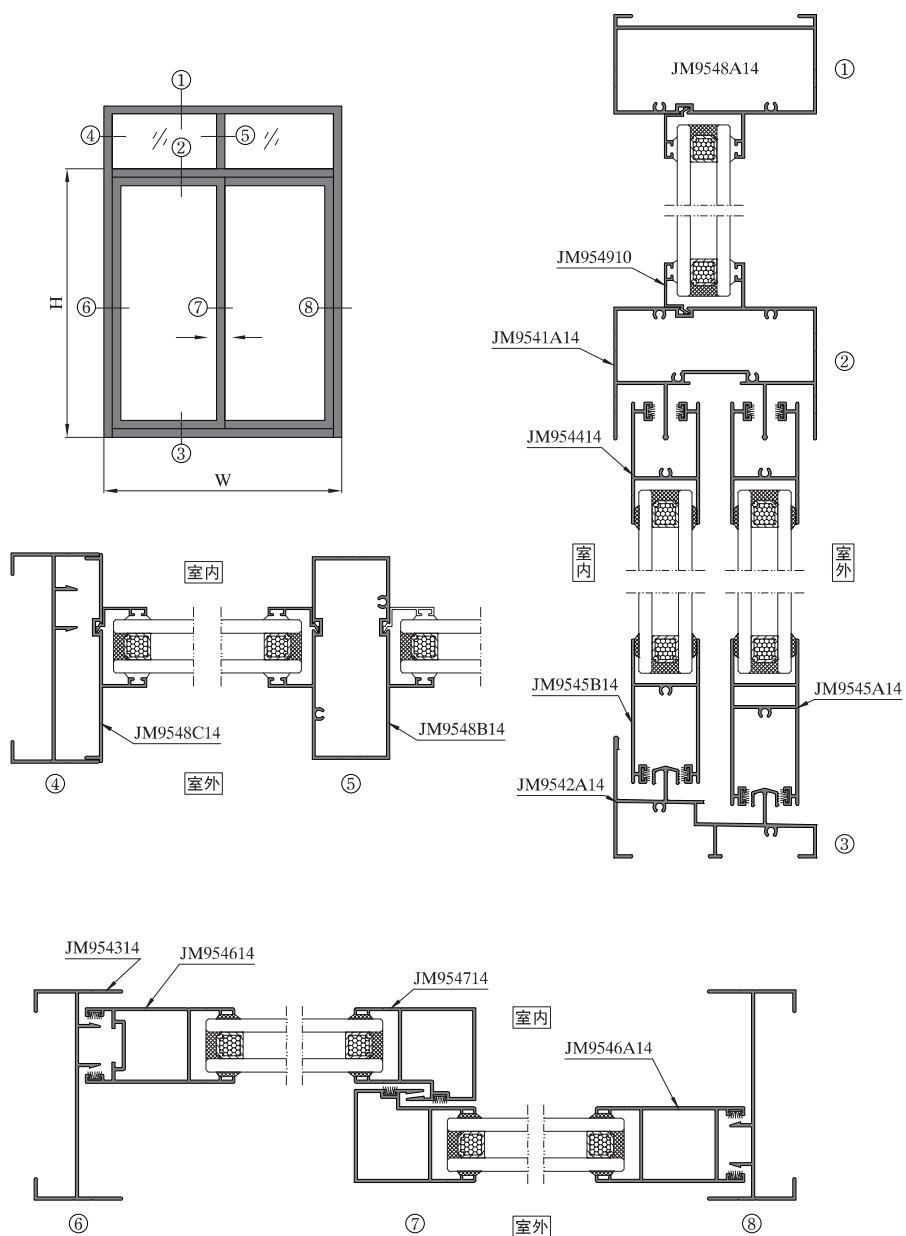

图中所示型材截面、装配、编号、尺寸及重量仅供参考。如有疑问，请向本公司查询。
Information above just for your reference. Please contact us if you have any questions, Thank you!

图中所示型材截面、装配、编号、尺寸及重量仅供参考。如有疑问，请向本公司查询。
Information above just for your reference. Please contact us if you have any questions, Thank you!

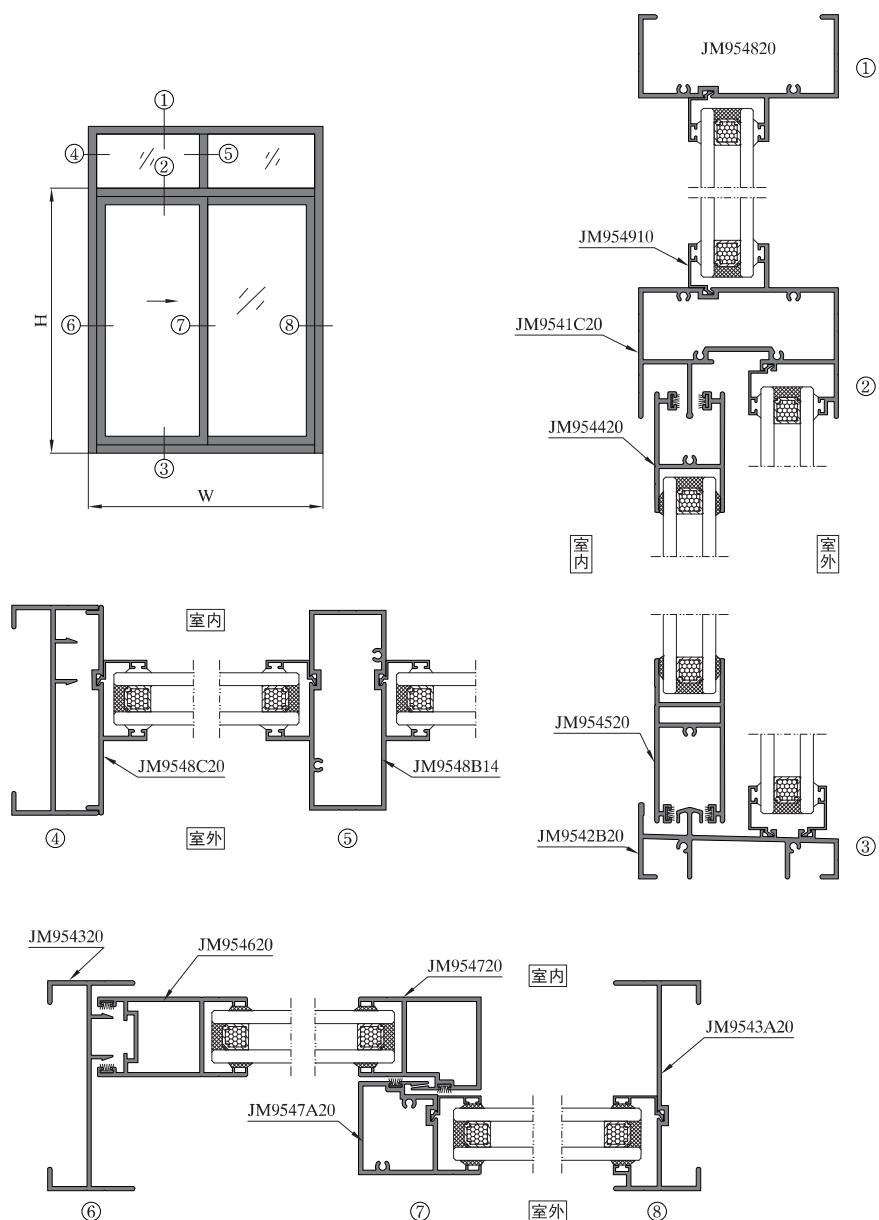

序号 S/N	型号理论重量 JMA Code & KG/M	型材图 Drawing	序号 S/N	型号理论重量 JMA Code & KG/M	型材图 Drawing	序号 S/N	型号理论重量 JMA Code & KG/M	型材图 Drawing
1	上滑 JM954114 1.051kg/m		10	固下滑 JM9542C14 1.743kg/m		19	光企 JM954614 0.945kg/m	
2	上滑 JM954120 1.49kg/m		11	边封 JM954314 0.858kg/m		20	光企 JM954620 1.307kg/m	
3	固上滑 JM9541A14 1.728kg/m		12	边封 JM954320 1.197kg/m		21	光企 JM9546A14 0.883kg/m	
4	固上滑 JM9541A20 2.428kg/m		13	边封 JM9543A20 1.241kg/m		22	光企 JM9546A20 1.256kg/m	
5	上滑 JM9541B20 1.457kg/m		14	上方 JM954414 0.738kg/m		23	勾企 JM954714 0.852kg/m	
6	固上滑 JM9541C20 2.394kg/m		15	上方 JM954420 1.008kg/m		24	勾企 JM954720 1.192kg/m	
7	下滑 JM954220 1.494kg/m		16	下方 JM954520 1.365kg/m		25	勾企 JM9547A20 1.186kg/m	
8	下滑 JM9542A14 1.186kg/m		17	下方 JM9545A14 0.991kg/m		26	上固 JM954820 1.295kg/m	
9	下滑 JM9542B20 1.414kg/m		18	下方 JM9545B14 0.795kg/m		27	上固 JM9548A14 1.361kg/m	

图中所示型材截面、装配、编号、尺寸及重量仅供参考。如有疑问，请向本公司查询。
Information above just for your reference. Please contact us if you have any questions, Thank you!

图中所示型材截面、装配、编号、尺寸及重量仅供参考。如有疑问，请向本公司查询。
Information above just for your reference. Please contact us if you have any questions, Thank you!

序号 S/N	型号理论重量 JMA Code & KG/M	型材图 Drawing	序号 S/N	型号理论重量 JMA Code & KG/M	型材图 Drawing	序号 S/N	型号理论重量 JMA Code & KG/M	型材图 Drawing
28	下方 JM9545E 0.905kg/m		37	中柱 JM9548B14 1.368kg/m		46		
29	下方 JM9545C14 1.116kg/m		38	中柱 JM9548B20 1.929kg/m		47		
30	下方 JM9545C 1.516kg/m		39	插板 JM9548C14 0.586kg/m		48		
31	光企 JM9546B14 1.044kg/m		40	插板 JM9548C20 0.822kg/m		49		
32	光企 JM9546B20 1.453kg/m		41	插板 JM9548D14 0.596kg/m		50		
33	勾企 JM9547B14 0.951kg/m		42	插板 JM9548D20 0.820kg/m		51		
34	勾企 JM9547B20 1.338kg/m		43	收口 JM9548E20 0.347kg/m		52		
35	上方 JM9544A14 0.848kg/m		44	压线 JM954910 0.123kg/m		53		
36	上方 JM9544A20 1.158kg/m		45	下滑 JM9542K 1.572kg/m		54		

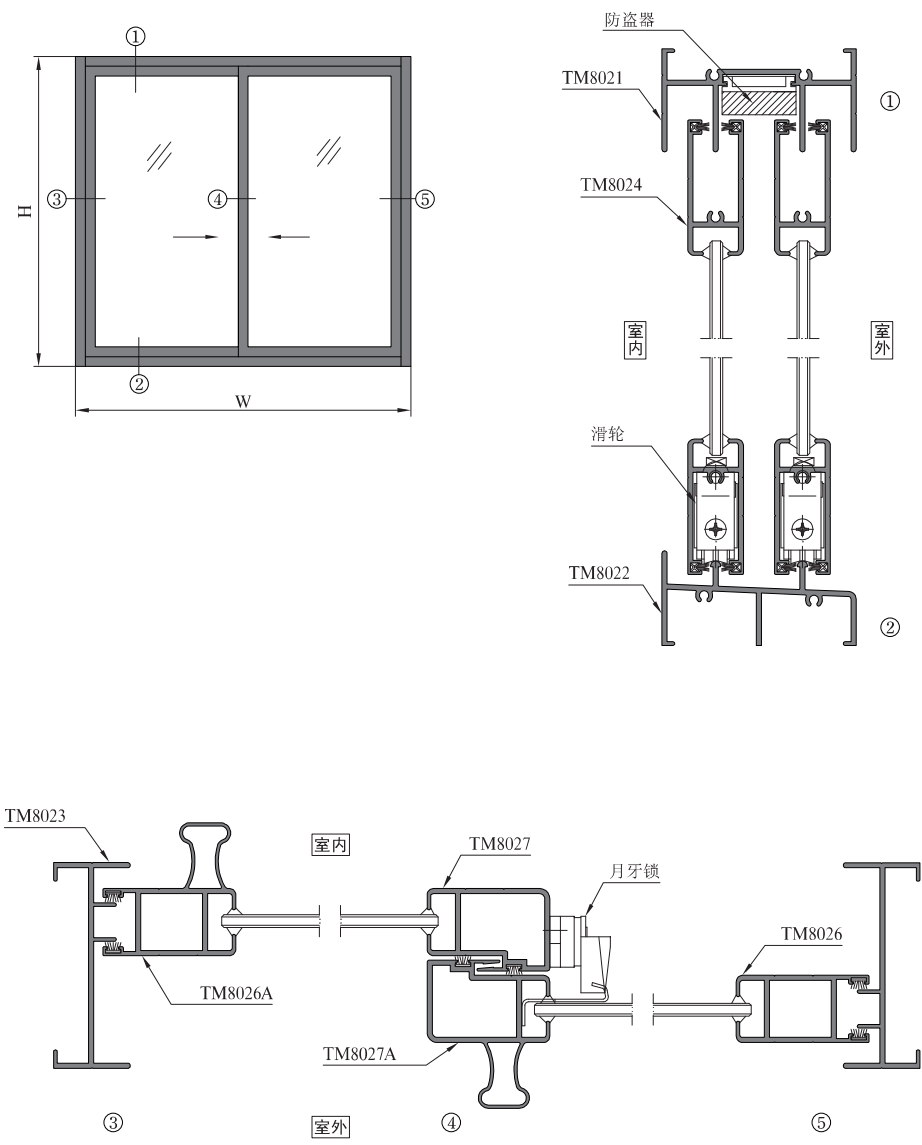

序号 S/N	型号理论重量 JMA Code & KG/M	型材图 Drawing	序号 S/N	型号理论重量 JMA Code & KG/M	型材图 Drawing	序号 S/N	型号理论重量 JMA Code & KG/M	型材图 Drawing
1	上滑 TM8021 1.312kg/m		10	上下方 TM8024E T=2.0 0.814kg/m		19		
2	下滑 TM8022 1.12kg/m		11	光企 TM8026D T=2.0 0.856kg/m		20		
3	边封 TM8023 0.908kg/m		12	勾企 TM8027E T=2.0 0.930kg/m		21		
4	上方 TM8024 0.816kg/m		13	上固 TM8028 T=2.0 0.901kg/m		22		
5	光企 TM8026 0.894kg/m		14	边封插板 TM8028B T=1.2 0.432kg/m		23		
6	光企 TM8026A 1.145kg/m		15	收口 TM8029 T=1.2 0.185kg/m		24		
7	勾企 TM8027 0.98kg/m		16			25		
8	勾企 TM8027A 1.23kg/m		17			26		
9	固上滑 TM8021A T=2.0 1.958kg/m		18			27		

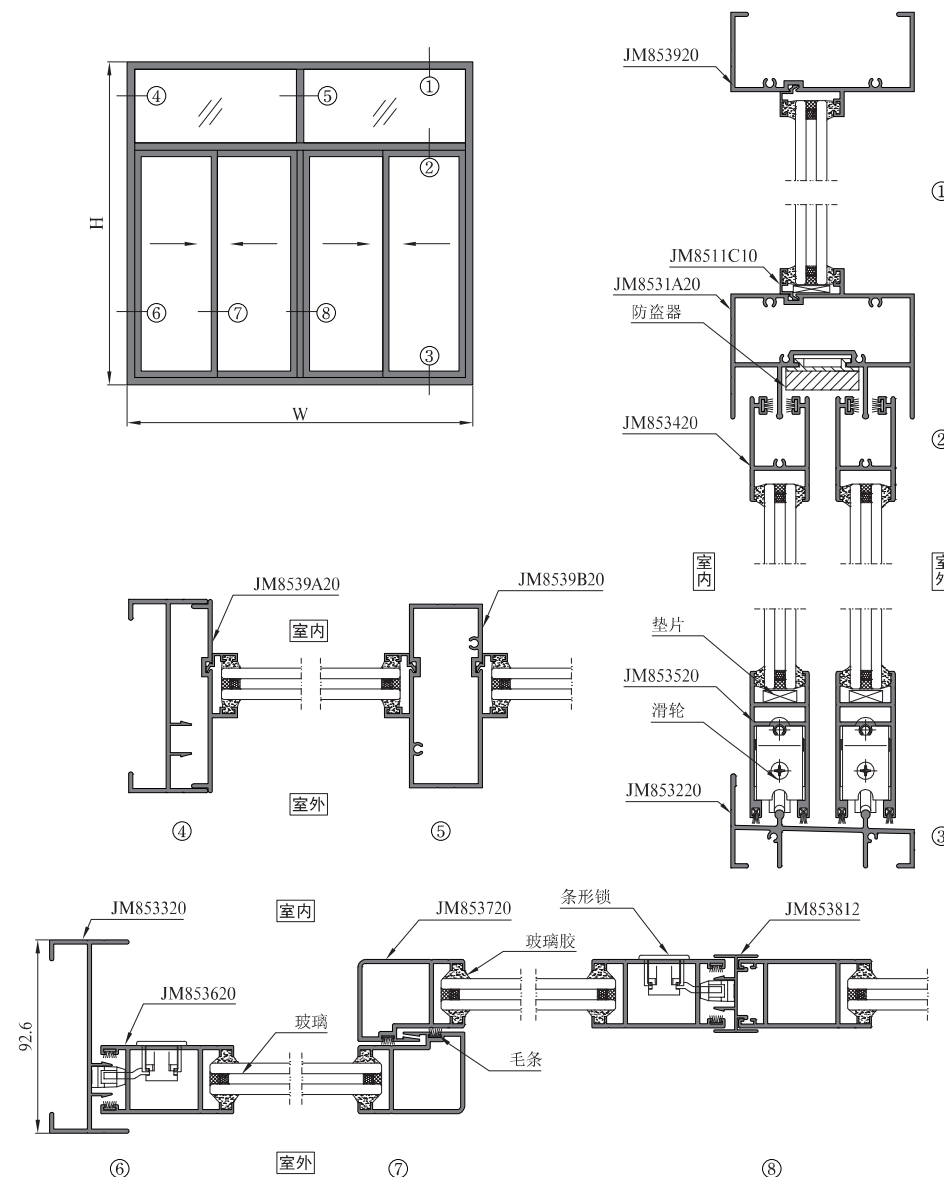

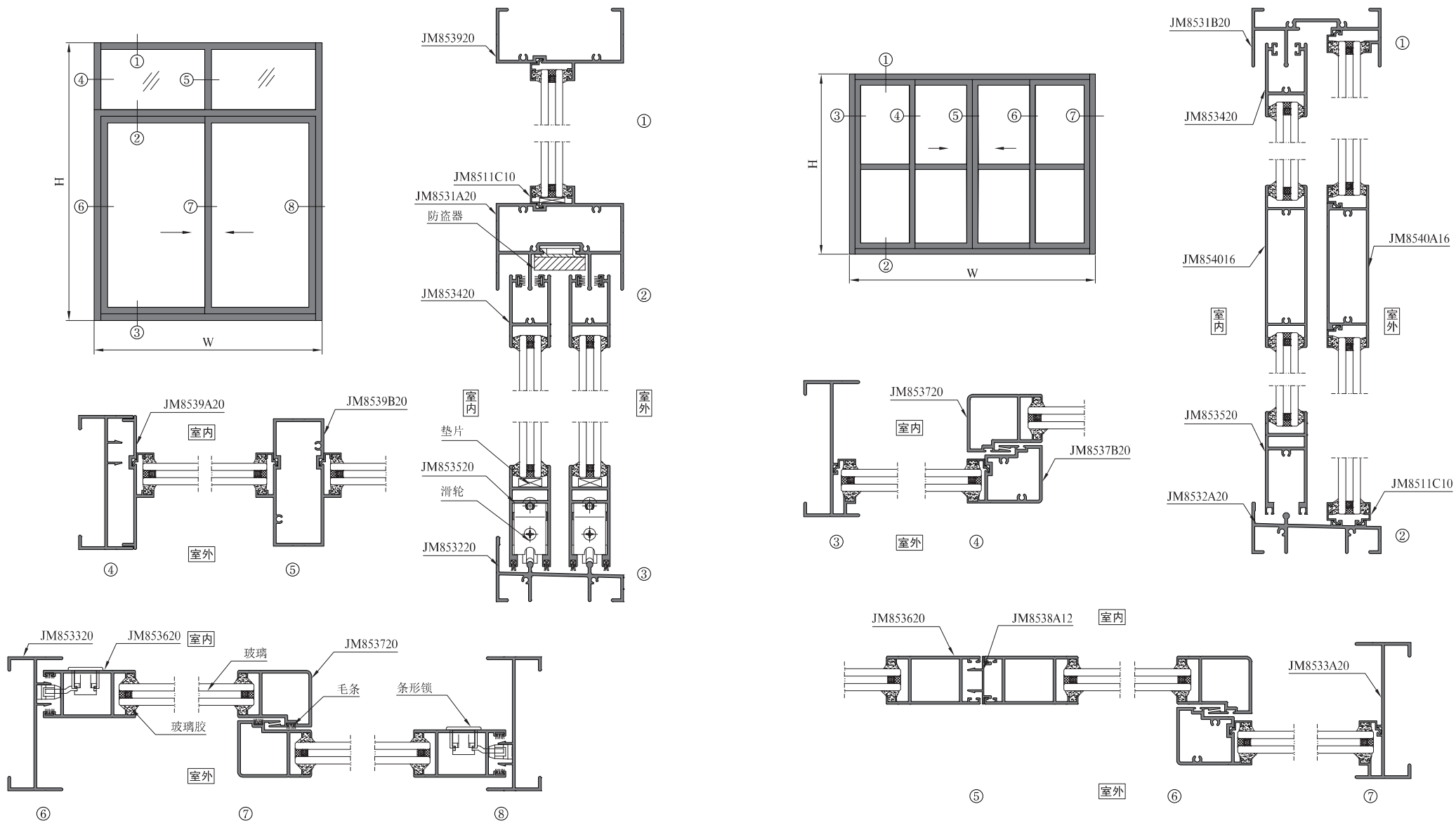

序号 S/N	型号理论重量 JMA Code & KG/M	型材图 Drawing	序号 S/N	型号理论重量 JMA Code & KG/M	型材图 Drawing	序号 S/N	型号理论重量 JMA Code & KG/M	型材图 Drawing
1	上滑 JM853120 1.463kg/m		10	上方 JM8534A20 1.016kg/m		19	中横 JM854016 1.385kg/m	
2	固上滑 JM8531A20 2.328kg/m		11	下方 JM853520 1.233kg/m		20	上固 JM853920 1.224kg/m	
3	上滑 JM8531B20 1.449kg/m		12	下方 JM8535A20 1.346kg/m		21	插板 JM8539A20 0.777kg/m	
4	固上滑 JM8531C20 2.331kg/m		13	光企 JM853620 1.166kg/m		22	中柱 JM8539B20 1.753kg/m	
5	下滑 JM853220 1.344kg/m		14	光企 JM8536A20 1.279kg/m		23	收口 JM853812 0.387kg/m	
6	下滑 JM8532A20 1.302kg/m		15	勾企 JM853720 1.097kg/m		24	收口 JM8538A12 0.232kg/m	
7	边封 JM853320 1.125kg/m		16	勾企 JM8537A20 1.216kg/m		25	压线 JM851110 0.132kg/m	玻璃开口12.3mm
8	边封 JM8533A20 1.183kg/m		17	勾企 JM8537B20 1.124kg/m		26	压线 JM8511A10 0.117kg/m	玻璃开口12.3mm
9	上方 JM853420 0.903kg/m		18	中横 JM8540A16 1.318kg/m		27	压线 JM8511C10 0.092kg/m	玻璃开口22mm

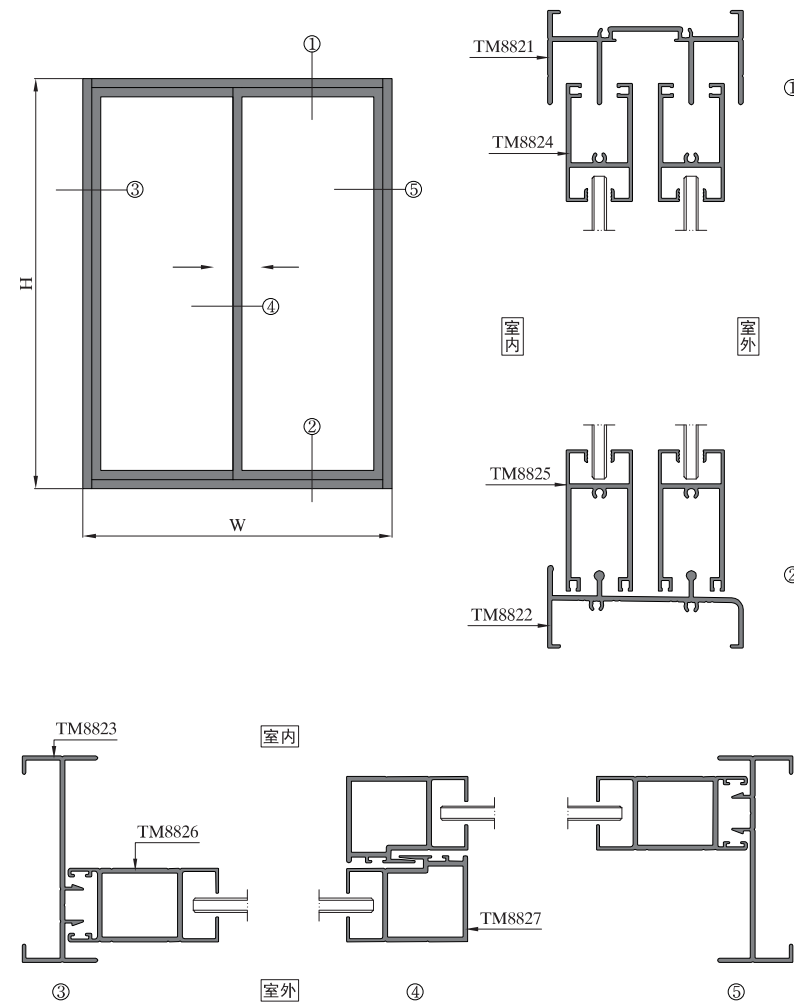

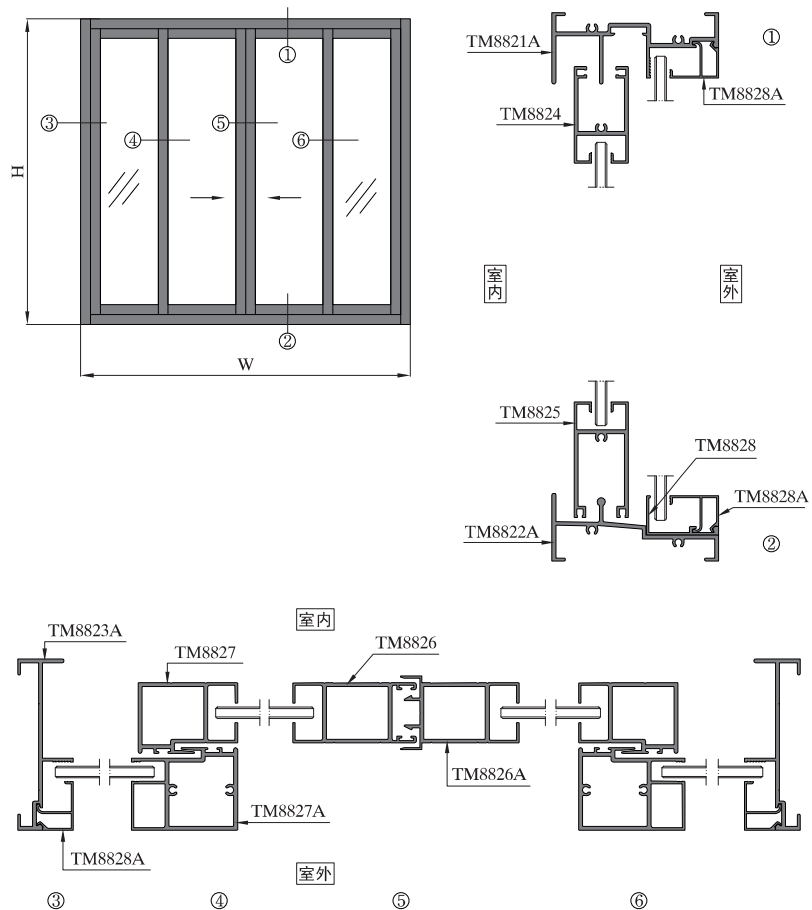

序号 S/N	型号理论重量 JMA Code & KG/M	型材图 Drawing	序号 S/N	型号理论重量 JMA Code & KG/M	型材图 Drawing	序号 S/N	型号理论重量 JMA Code & KG/M	型材图 Drawing
1	TM8821 1.333kg/m		10	TM8826A 1.089kg/m		19		
2	TM8821A 1.245kg/m		11	TM8827 1.041kg/m		20		
3	TM8822 1.010kg/m		12	TM8827A 1.299kg/m		21		
4	TM8822A 0.985kg/m		13	TM8828 0.244kg/m		22		
5	TM8823 0.943kg/m		14	TM8828A 0.210kg/m		23		
6	TM8823A 0.860kg/m		15			24		
7	TM8824 0.847kg/m		16			25		
8	TM8825 0.955kg/m		17			26		
9	TM8826 1.063kg/m		18			27		

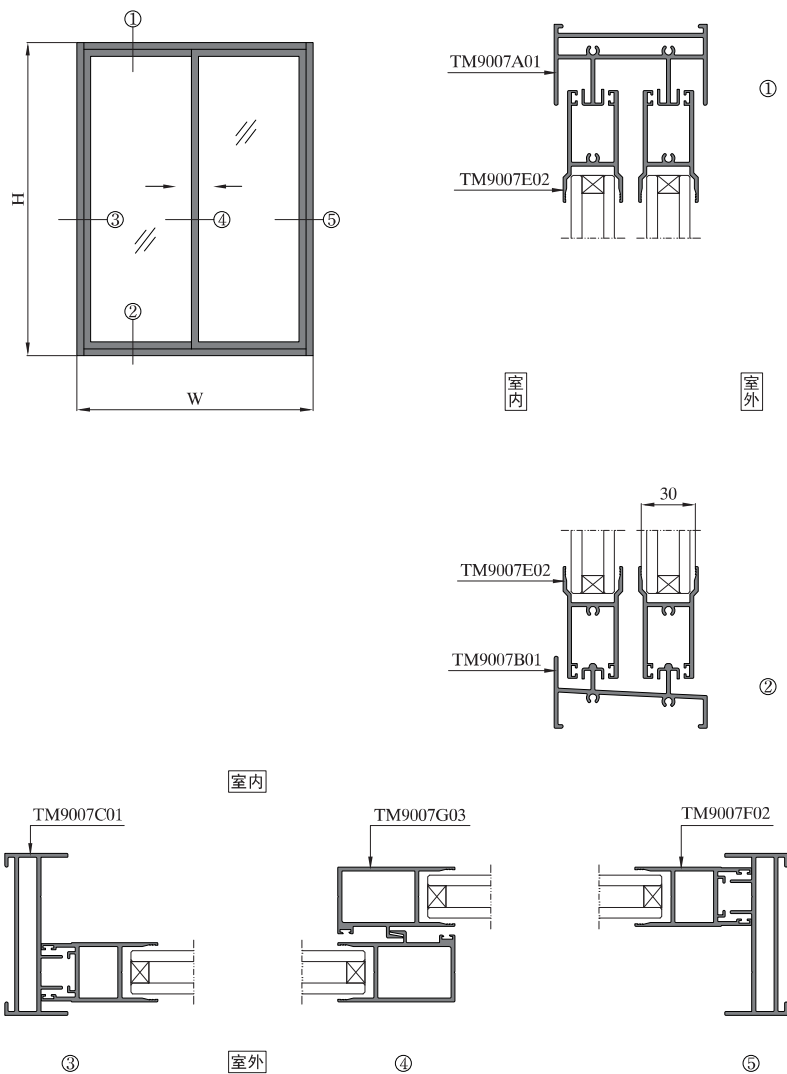

序号 S/N	型号理论重量 JMA Code & KG/M	型材图 Drawing	序号 S/N	型号理论重量 JMA Code & KG/M	型材图 Drawing	序号 S/N	型号理论重量 JMA Code & KG/M	型材图 Drawing
1	上滑 TM9007A01 2.252kg/m		10			19		
2	下滑 TM9007B01 1.377kg/m		11			20		
3	边封 TM9007C01 1.712kg/m		12			21		
4	上下方 TM9007E02 1.018kg/m		13			22		
5	光企 TM9007F02 1.224kg/m		14			23		
6	勾企 TM9007G03 1.298kg/m		15			24		
7			16			25		
8			17			26		
9			18			27		

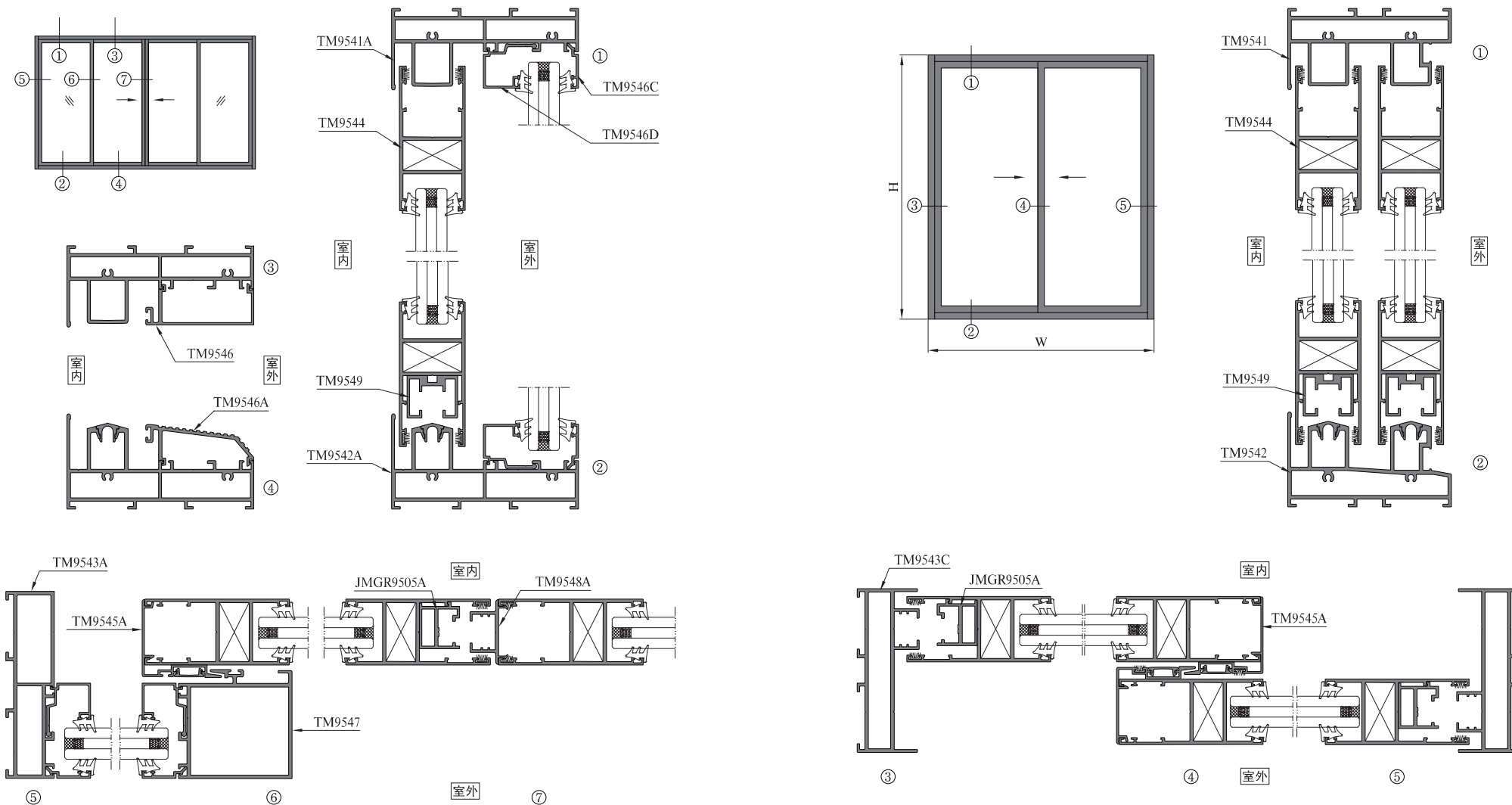

序号 S/N	型号理论重量 JMA Code & KG/M	型材图 Drawing	序号 S/N	型号理论重量 JMA Code & KG/M	型材图 Drawing	序号 S/N	型号理论重量 JMA Code & KG/M	型材图 Drawing
1	上滑 TM9541 2.4kg/m		10	勾企扣条 TM9545 0.518kg/m		19	滑轮槽 TM9549 0.572kg/m	
2	上滑 TM9541A 2.339kg/m		11	勾企扣条 TM9545A 0.444kg/m 配塑料件		20	盖板 TM9549B 0.886kg/m	
3	带固上滑 TM9541B 2.624kg/m		12	压线 TM9546 0.576kg/m		21	上固 TM9549E 1.793kg/m	
4	下滑 TM9542 2.535kg/m		13	压线 TM9546A 0.617kg/m		22	锁座 JMGR9014 0.31kg/m	
5	下滑 TM9542A 2.426kg/m		14	压线 TM9546B 0.397kg/m		23	连杆 JMGR9015 0.122kg/m	
6	边封 TM9543A 1.824kg/m		15	压线 TM9546C 0.143kg/m		24	锁座 JMGR9505A 0.499kg/m	
7	加强中挺 TM9543B 2.039kg/m		16	压线 TM9546D 0.324kg/m		25		
8	边封 TM9543C 1.725kg/m		17	勾企 TM9547 1.673kg/m		26		
9	扇料 TM9544 1.379kg/m		18	收口 TM9548A 0.416kg/m		27		

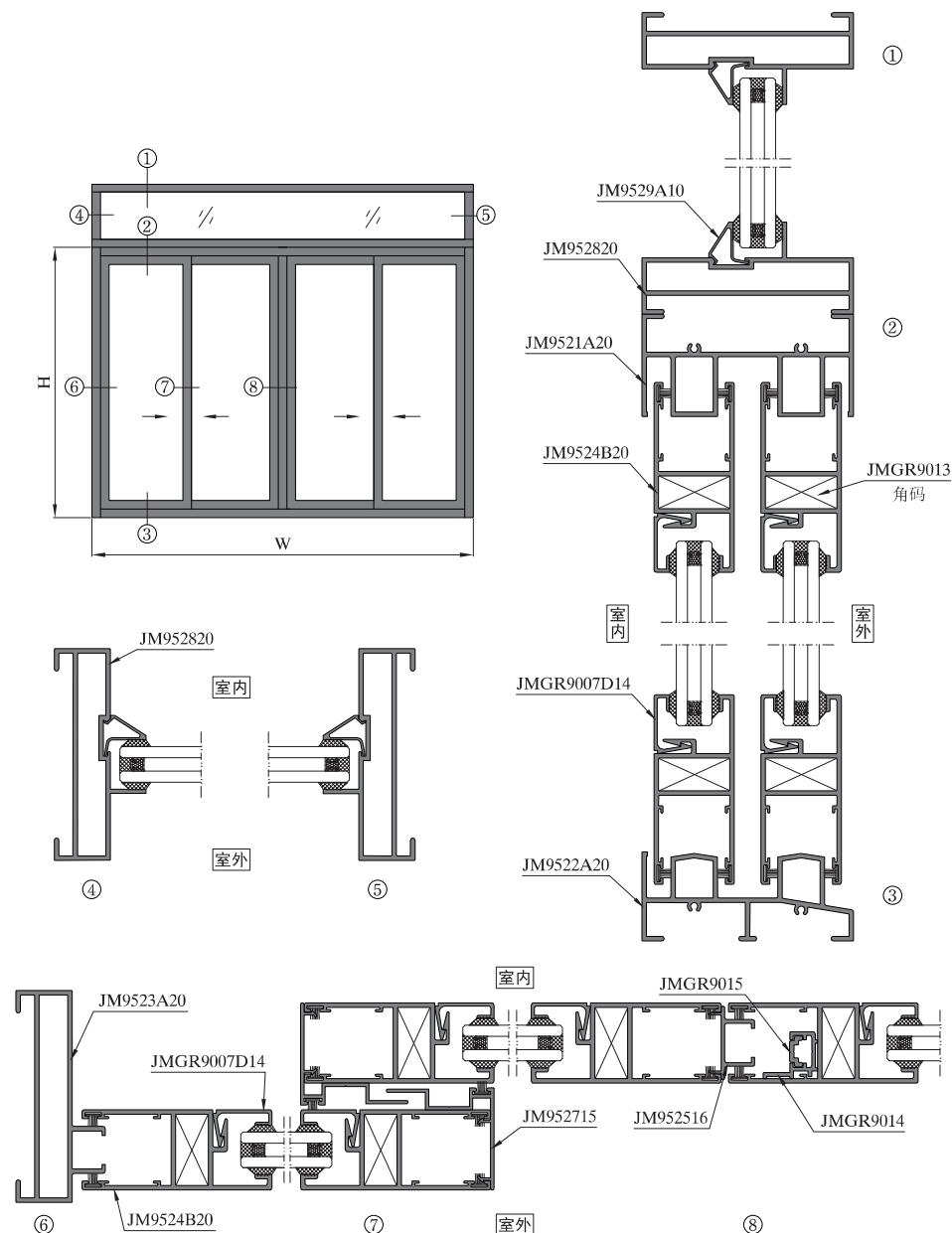

图中所示型材截面、装配、编号、尺寸及重量仅供参考。如有疑问，请向本公司查询。
Information above just for your reference. Please contact us if you have any questions, Thank you!

图中所示型材截面、装配、编号、尺寸及重量仅供参考。如有疑问，请向本公司查询。
Information above just for your reference. Please contact us if you have any questions, Thank you!

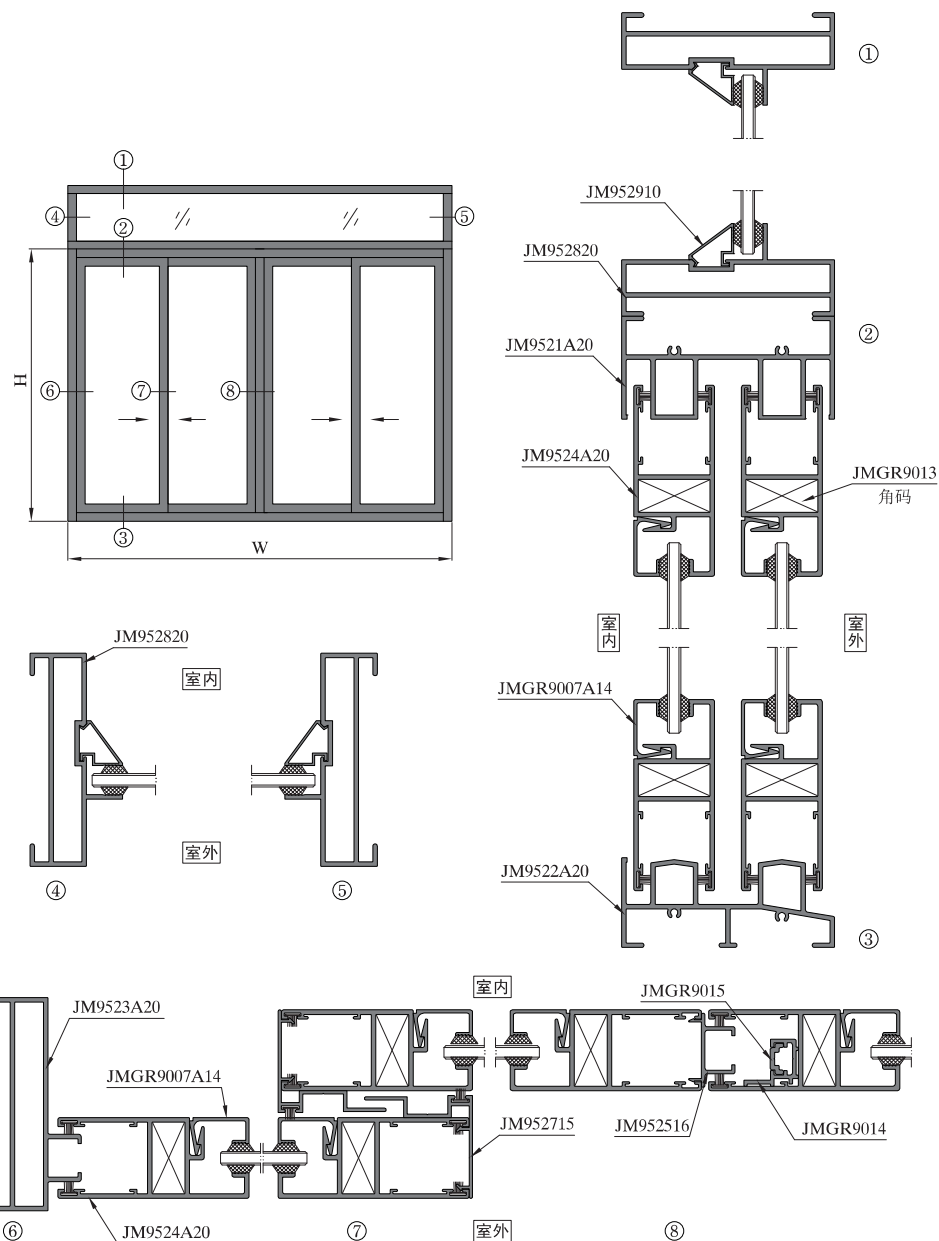



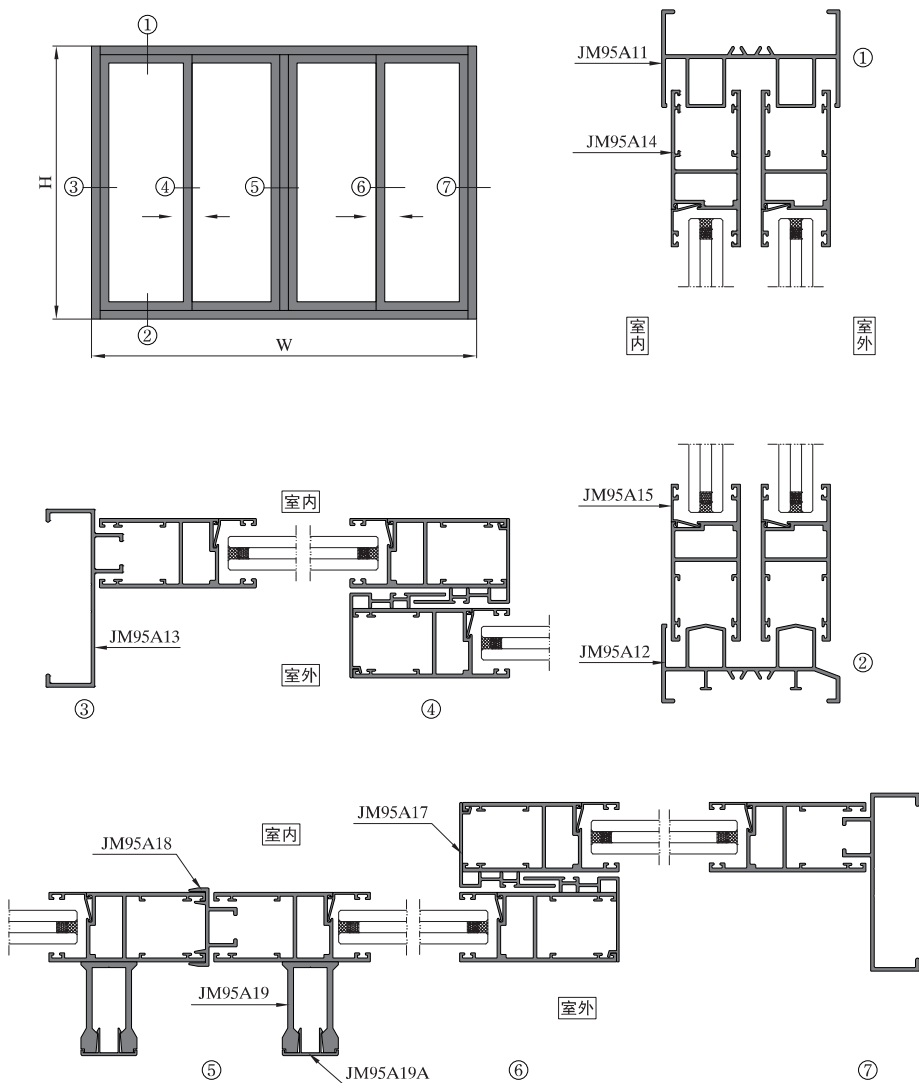

序号 S/N	型号理论重量 JMA Code & KG/M	型材图 Drawing	序号 S/N	型号理论重量 JMA Code & KG/M	型材图 Drawing	序号 S/N	型号理论重量 JMA Code & KG/M	型材图 Drawing
1	上滑 JM9521A20 2.048kg/m		10	勾金扣条 JM9527B15 0.500kg/m		19	连杆 JMGR9015 0.122kg/m	
2	下滑 JM9522A20 1.804kg/m		11	收口 JM952516 0.334kg/m		20	角码 JMGR9013 2.051kg/m	
3	下滑 JM9522C20 2.038kg/m		12	JM9525D 0.453kg/m		21	角铝 JM103120 0.176kg/m	
4	边封 JM9523A20 1.642kg/m		13	上固定 JM952820 1.590kg/m		22	收口 JM9525H 0.435kg/m	
5	扇料 JM9524A20 1.463kg/m	角码配JMGR9013 	14	压线 JM952910 0.158kg/m	玻璃开口13mm 	23	锁槽 JM9530 0.383kg/m	
6	扇料 JM9524B20 1.436kg/m	角码配JMGR9013 	15	压线 JM9529A10 0.139kg/m	玻璃开口22mm 	24	扇料压线 JMGR9007 0.187kg/m	
7	扇料 JM9524A16 1.221kg/m	角码配JMGR9013 	16	压线 JMGR9007A14 0.242kg/m	玻璃开口13mm 	25		
8	扇料 JM9524J20 2.124kg/m	角码配JMGR9013 	17	压线 JMGR9007D14 0.224kg/m	玻璃开口22mm 配JM9524B20 	26		
9	勾金扣条 JM952715 0.534kg/m		18	JMGR9014 0.310kg/m		27		

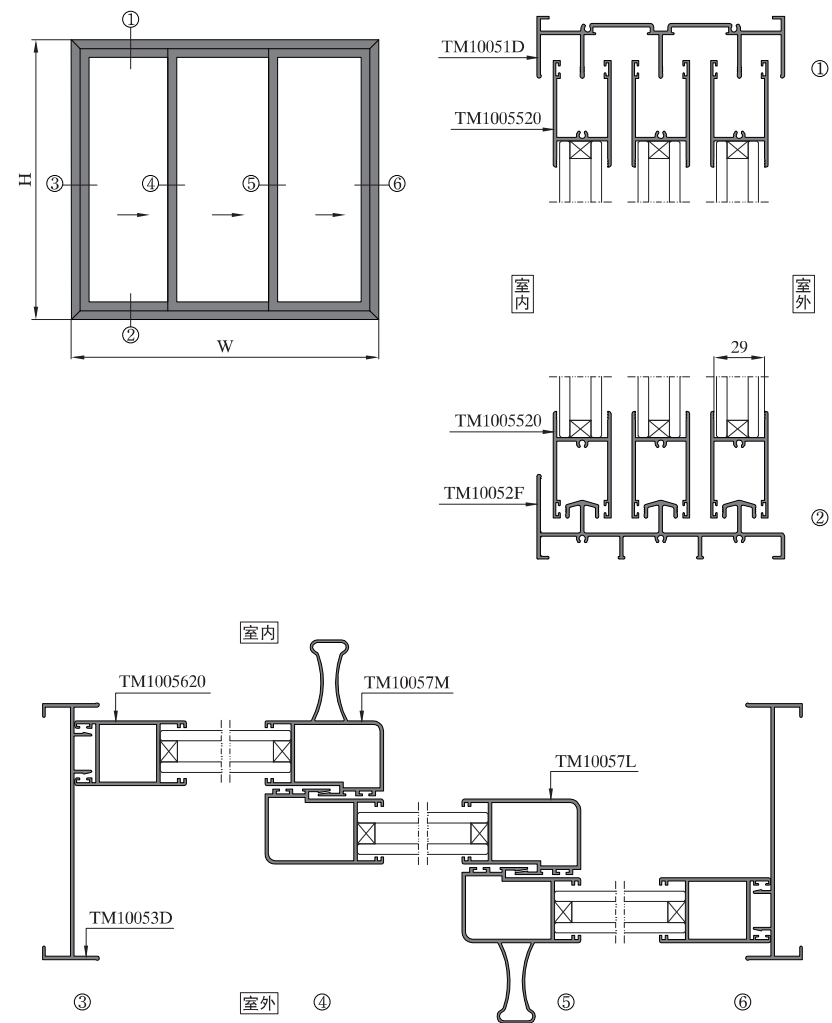
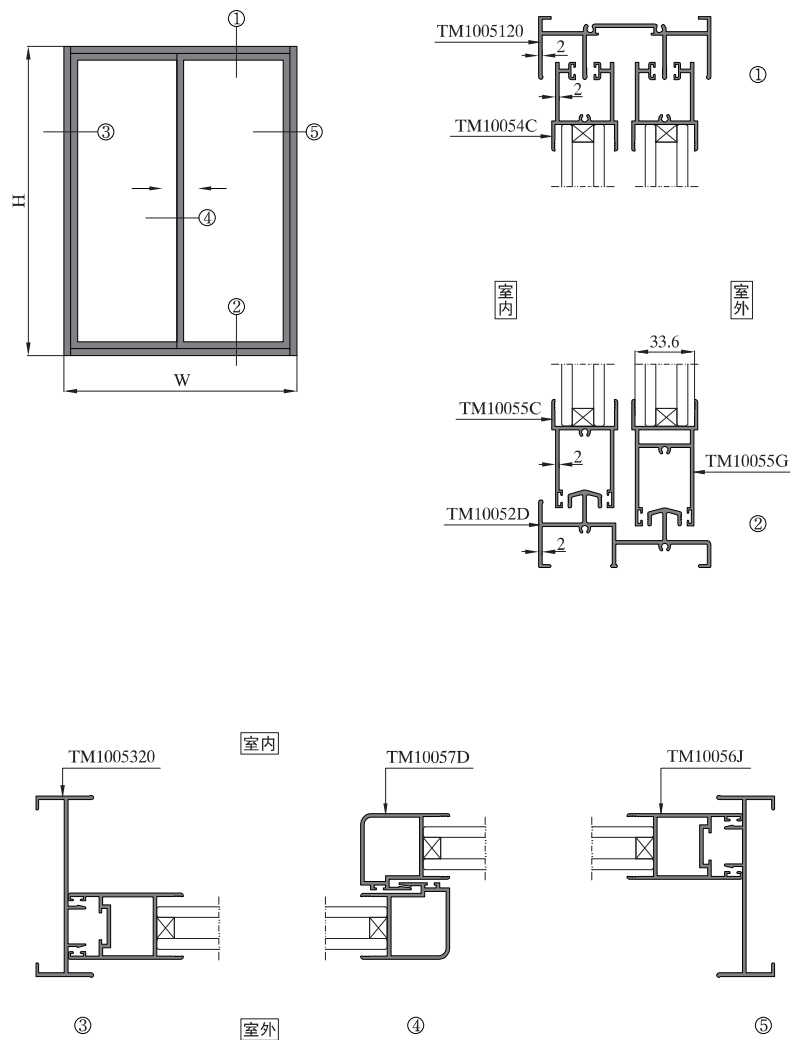

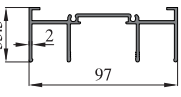
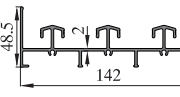
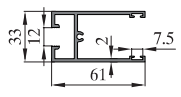
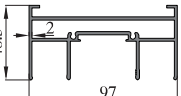
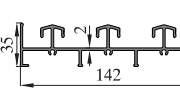
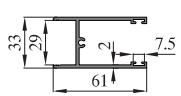
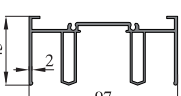
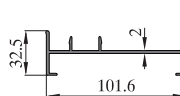
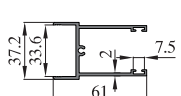
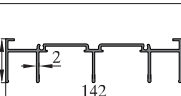
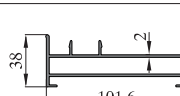
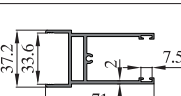
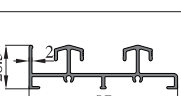
序号 S/N	型号理论重量 JMA Code & KG/M	型材图 Drawing	序号 S/N	型号理论重量 JMA Code & KG/M	型材图 Drawing	序号 S/N	型号理论重量 JMA Code & KG/M	型材图 Drawing
1	上滑 JM95A11 1.908kg/m		10	JM95A19B 0.446kg/m		19		
2	下滑 JM95A12 1.648kg/m		11	上滑 JM95A11A 1.749kg/m		20		
3	边封 JM95A13 1.076kg/m		12	上滑 JM95A11B 2.588kg/m		21		
4	扇料 JM95A14 1.383kg/m		13	下滑 JM95A12A 1.725kg/m		22		
5	扇压线 JM95A15 0.141kg/m		14	下滑 JM95A12B 2.467kg/m		23		
6	单勾 JM95A17 0.536kg/m		15	边封 JM95A13A 1.140kg/m		24		
7	收口 JM95A18 0.536kg/m		16	边封 JM95A13B 1.677kg/m		25		
8	把手 JM95A19 1.398kg/m		17	扇压线 JM95A14A 0.131kg/m		26		
9	把手盖板 JM95A19A 0.215kg/m		18	收口 JM95A18A 0.521kg/m		27		

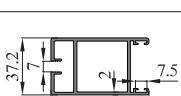
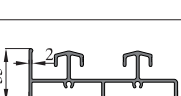
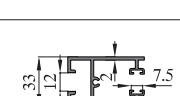
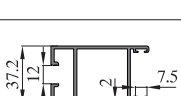
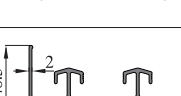
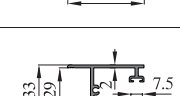
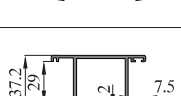
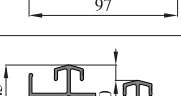
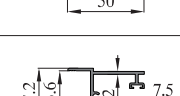

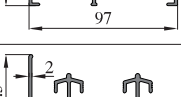
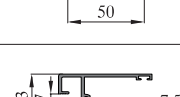
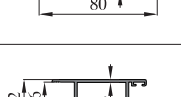
序号 S/N	型号理论重量 JMA Code & KG/M	型材图 Drawing	序号 S/N	型号理论重量 JMA Code & KG/M	型材图 Drawing	序号 S/N	型号理论重量 JMA Code & KG/M	型材图 Drawing
1	上滑 TM1005120 1.396kg/m		10	下滑 TM10052F 2.312kg/m		19	下方 TM10055A20 1.065kg/m	
2	上滑 TM10051C 2.093kg/m		11	下滑 TM10052FA 2.233kg/m		20	下方 TM1005520 0.930kg/m	
3	上滑 TM10051E 1.810kg/m		12	边封 TM1005320 1.096kg/m		21	下方 TM10055C 0.937kg/m	
4	上滑 TM10051D 1.868kg/m		13	边封 TM10053C 1.731kg/m		22	下方 TM10055G 1.224kg/m	
5	下滑 TM1005220 1.482kg/m		14	边封 TM10053D 1.360kg/m		23	光企 TM10056C 1.353kg/m	
6	下滑 TM10052BA 1.578kg/m		15	上方 TM10054A20 1.097kg/m		24	光企 TM10056B20 1.332kg/m	
7	下滑 TM10052B 1.657kg/m		16	上方 TM1005420 0.961kg/m		25	光企 TM1005620 1.199kg/m	
8	下滑 TM10052D 1.653kg/m		17	上方 TM10054C 0.969kg/m		26	光企 TM10056G 1.386kg/m	
9	下滑 TM10052E 1.874kg/m		18	下方 TM10055B 1.103kg/m		27	光企 TM10056D 1.153kg/m	

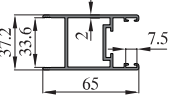
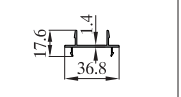
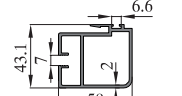
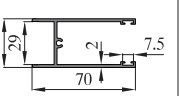
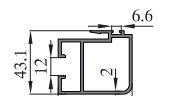
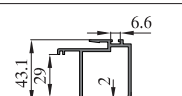
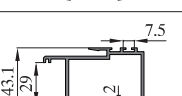
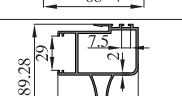
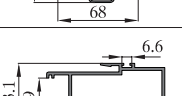
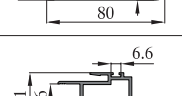
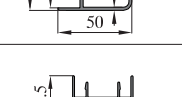
序号 S/N	型号理论重量 JMA Code & KG/M	型材图 Drawing	序号 S/N	型号理论重量 JMA Code & KG/M	型材图 Drawing	序号 S/N	型号理论重量 JMA Code & KG/M	型材图 Drawing
28	光企 TM10056J 1.237kg/m		37	收口 TM10058B 0.261kg/m		46		
29	勾企 TM10057C 1.271kg/m		38	下方 TM10055E 1.036kg/m		47		
30	勾企 TM10057B20 1.233kg/m		39			48		
31	勾企 TM1005720 1.116kg/m		40			49		
32	勾企 TM10057L 1.351kg/m		41			50		
33	勾企 TM10057M 1.820kg/m		42			51		
34	勾企 TM10057G 1.467kg/m		43			52		
35	勾企 TM10057D 1.071kg/m		44			53		
36	收口 TM1005814 0.542kg/m		45			54		

图中所示型材截面、装配、编号、尺寸及重量仅供参考。如有疑问，请向本公司查询。
 Information above just for your reference. Please contact us if you have any questions, Thank you!

图中所示型材截面、装配、编号、尺寸及重量仅供参考。如有疑问，请向本公司查询。
 Information above just for your reference. Please contact us if you have any questions, Thank you!

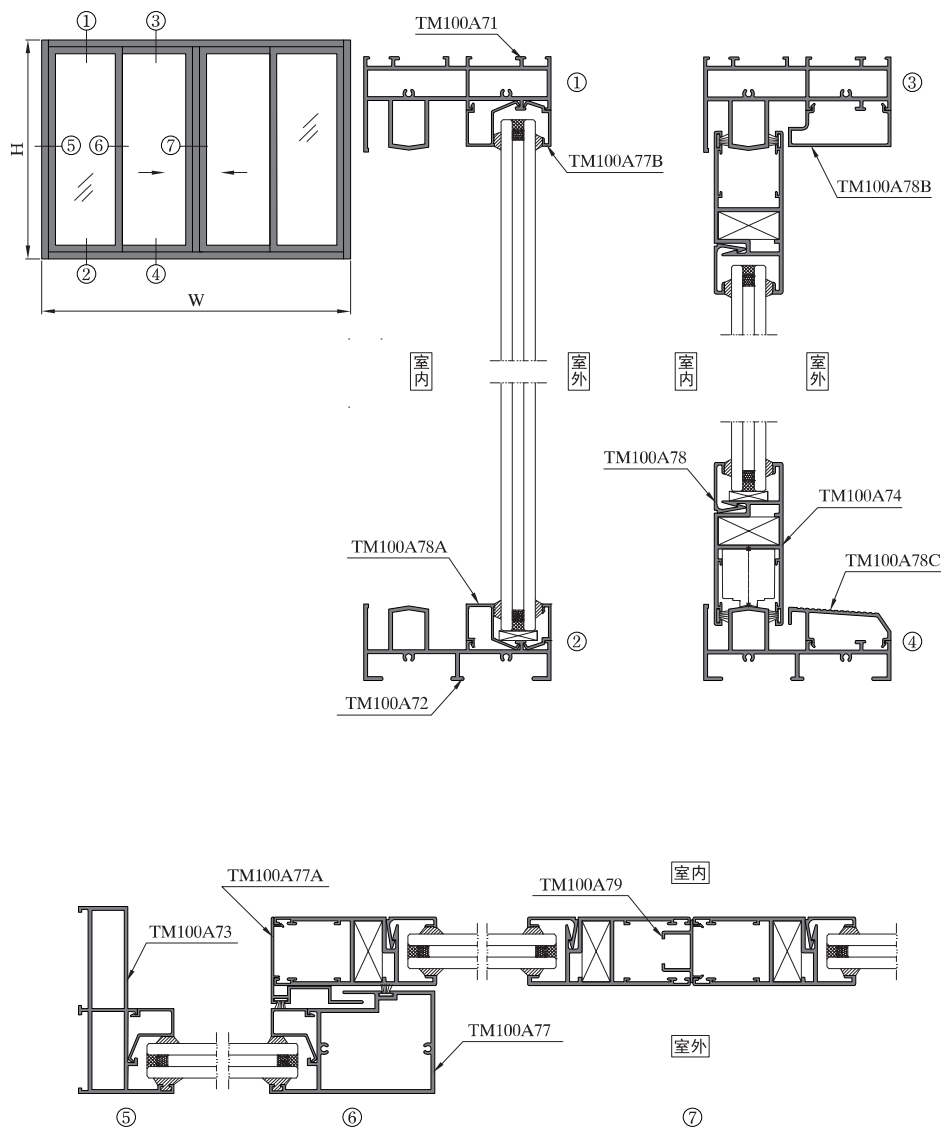

序号 S/N	型号理论重量 JMA Code & KG/M	型材图 Drawing	序号 S/N	型号理论重量 JMA Code & KG/M	型材图 Drawing	序号 S/N	型号理论重量 JMA Code & KG/M	型材图 Drawing
1	上滑 TM100A71 2.284kg/m		10	上滑盖板 TM100A78B 0.442kg/m		19		
2	下滑 TM100A72 1.599kg/m		11	下滑盖板 TM100A78C 0.457kg/m		20		
3	边封 TM100A73 1.747kg/m		12	收口 TM100A79 0.306kg/m		21		
4	扇料 TM100A74 1.428kg/m		13			22		
5	固定勾企 TM100A77 1.699kg/m		14			23		
6	单勾 TM100A77A 0.469kg/m		15			24		
7	框压线 TM100A77B 0.166kg/m		16			25		
8	扇压线 TM100A78 0.21kg/m		17			26		
9	框压线 TM100A78A 0.252kg/m		18			27		

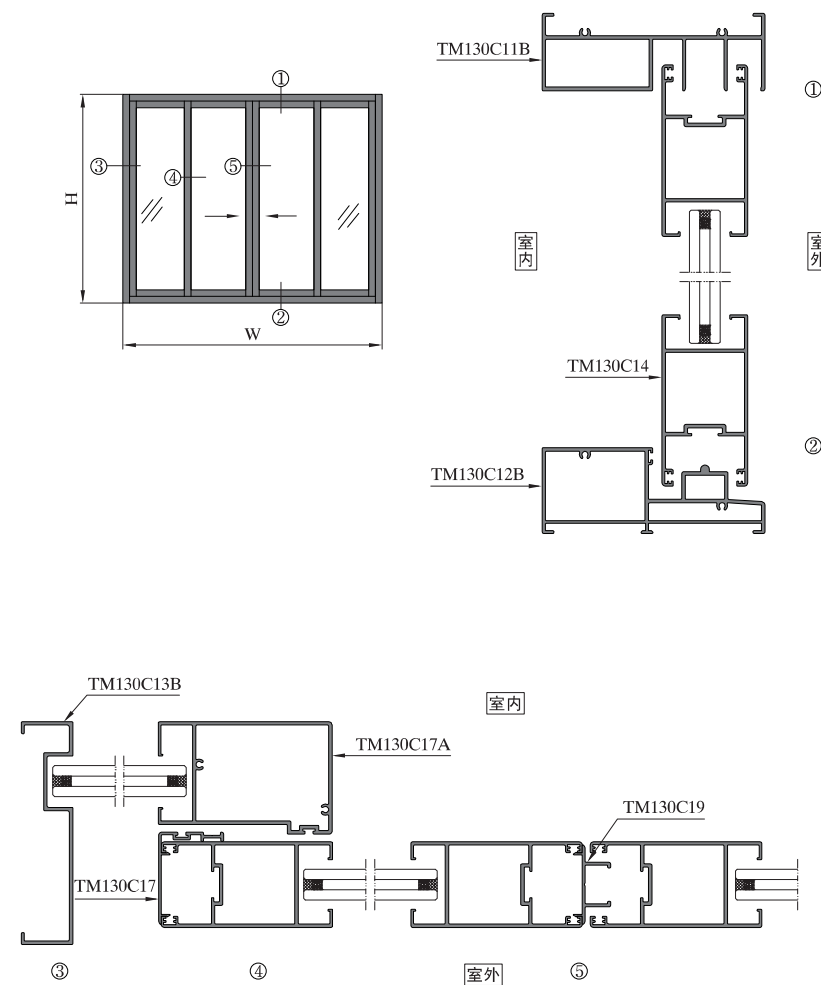
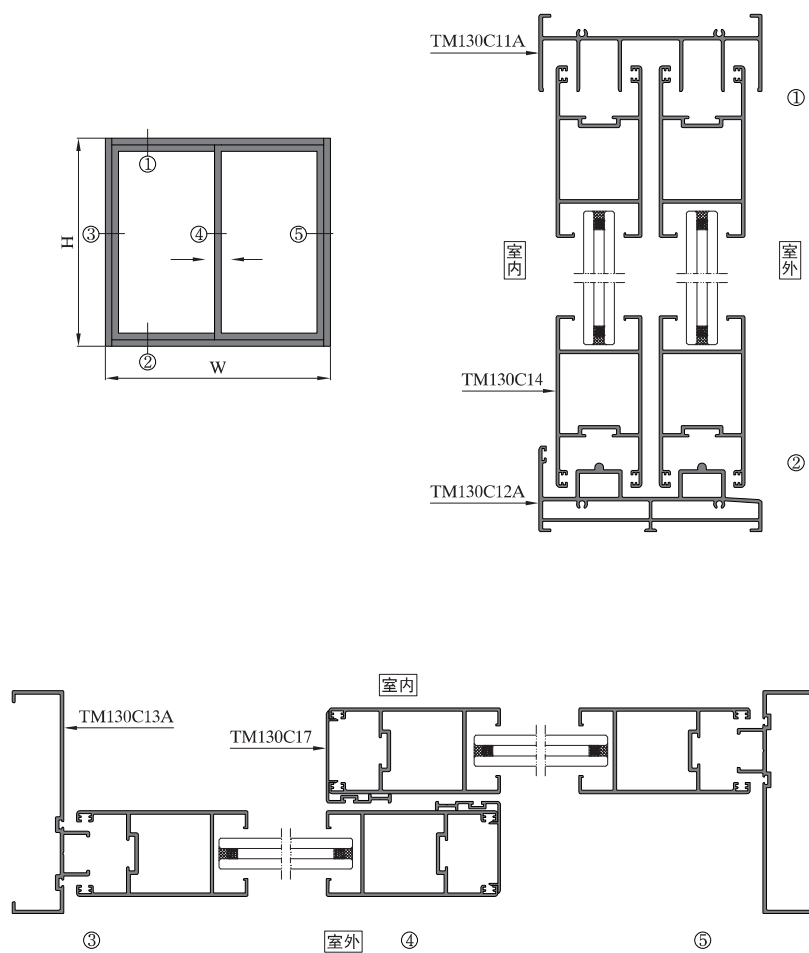

序号 S/N	型号理论重量 JMA Code & KG/M	型材图 Drawing	序号 S/N	型号理论重量 JMA Code & KG/M	型材图 Drawing	序号 S/N	型号理论重量 JMA Code & KG/M	型材图 Drawing
1	上滑 TM130C11A 2.024kg/m		10	收口 TM130C19 0.406kg/m		19		
2	上滑 TM130C11B 2.237kg/m		11			20		
3	下滑 TM130C12A 2.679kg/m		12			21		
4	下滑 TM130C12B 2.503kg/m		13			22		
5	边封 TM130C13A 1.373kg/m		14			23		
6	边封 TM130C13B 1.312kg/m		15			24		
7	扇料 TM130C14 1.953kg/m		16			25		
8	勾企扣条 TM130C17 0.471kg/m		17			26		
9	扇料 TM130C17A 2.147kg/m		18			27		

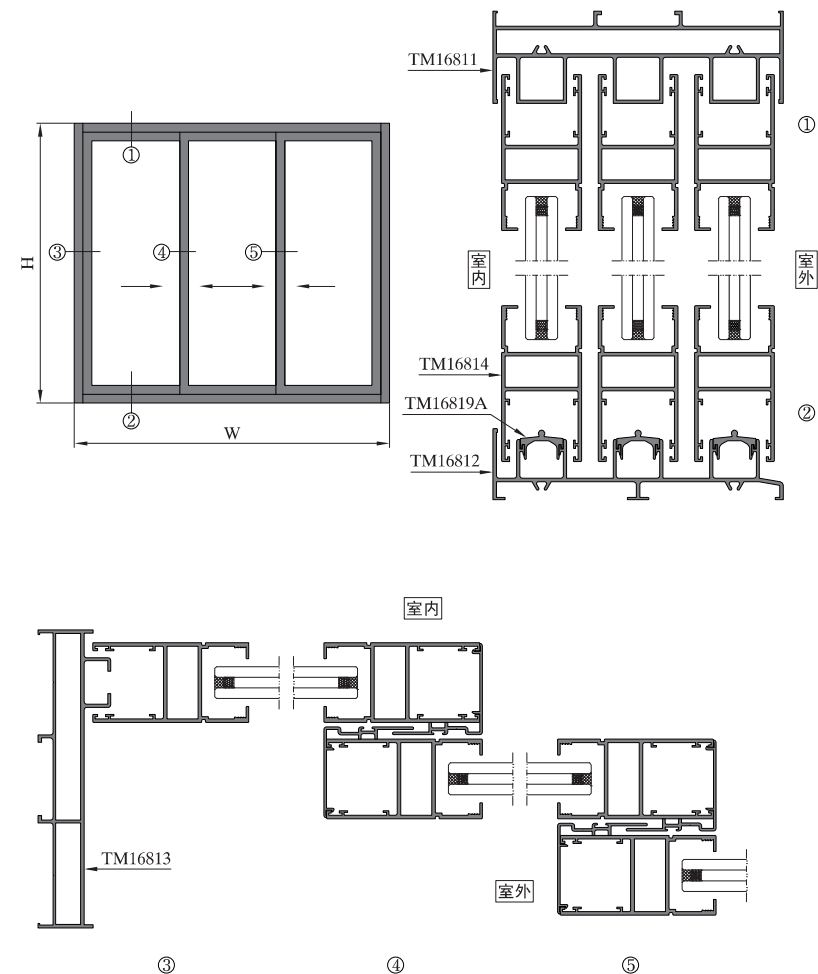

序号 S/N	型号理论重量 JMA Code & KG/M	型材图 Drawing	序号 S/N	型号理论重量 JMA Code & KG/M	型材图 Drawing	序号 S/N	型号理论重量 JMA Code & KG/M	型材图 Drawing
1	上滑 TM16811 3.853kg/m		10			19		
2	下滑 TM16812 2.247kg/m		11			20		
3	边封 TM16813 2.376kg/m		12			21		
4	扇料 TM16814 1.704kg/m		13			22		
5	勾企扣条 TM16817 0.531kg/m		14			23		
6	TM16819A 0.307kg/m		15			24		
7	收口 TM16819B 0.480kg/m		16			25		
8	角码 JM5508 3.533kg/m		17			26		
9			18			27		

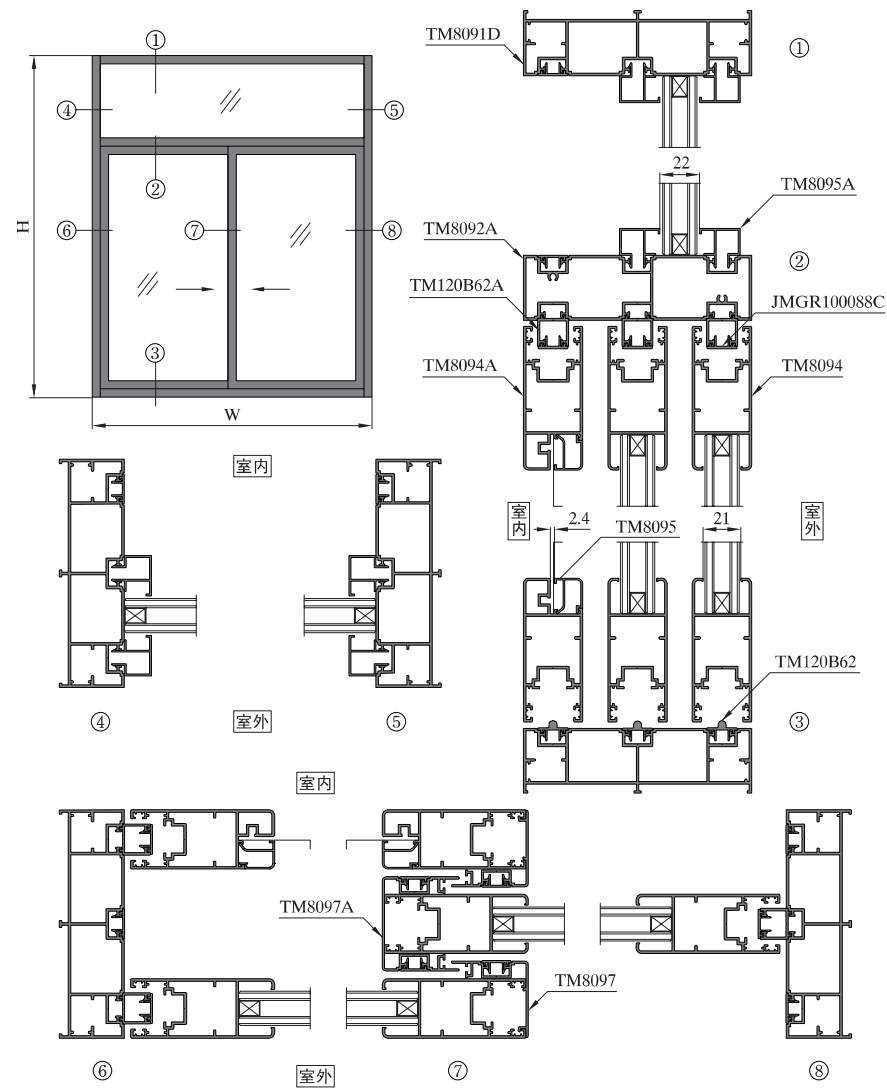

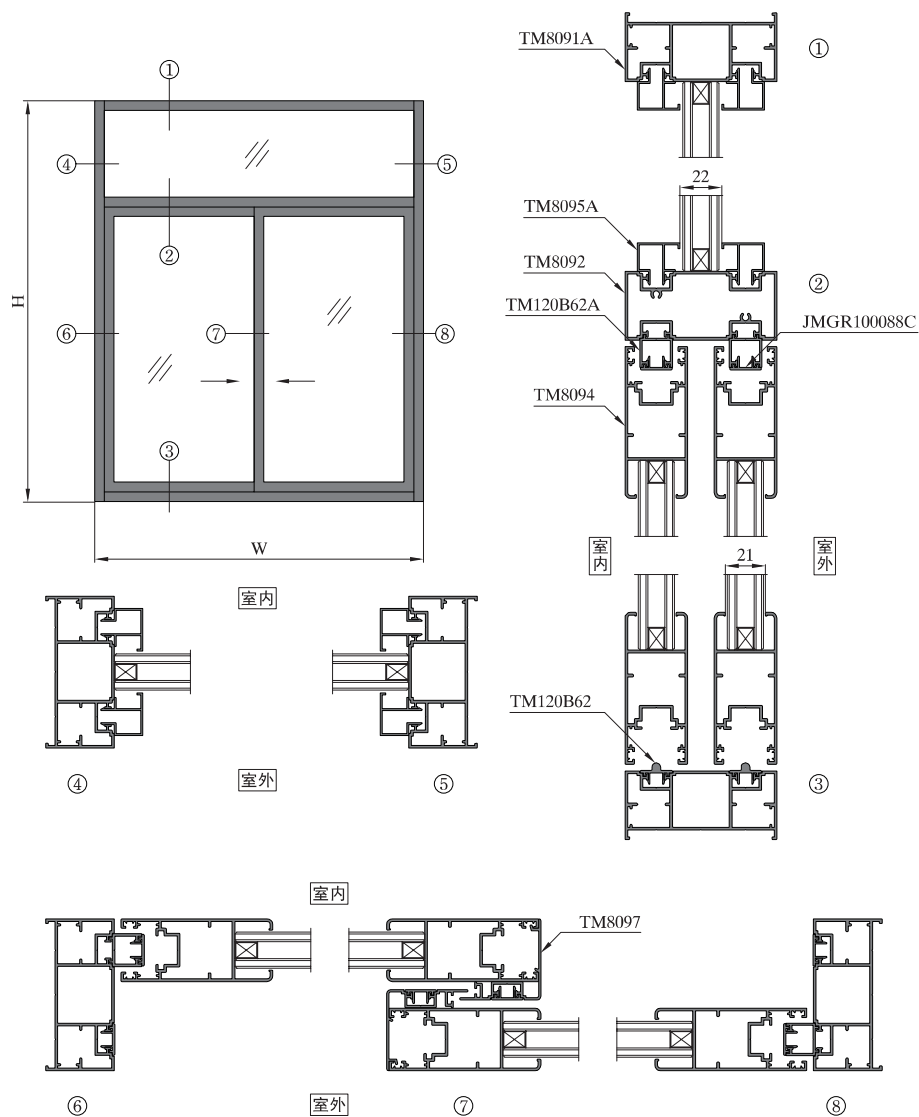

序号 S/N	型号理论重量 JMA Code & KG/M	型材图 Drawing	序号 S/N	型号理论重量 JMA Code & KG/M	型材图 Drawing	序号 S/N	型号理论重量 JMA Code & KG/M	型材图 Drawing
1	边框 TM8091A T=1.4 1.383kg/m		10	纱扇 TM8094A T=1.4 1.237kg/m		19	滑道槽 TM120B62A T=1.2 0.205kg/m	
2	边框 TM8091B T=1.4 1.526kg/m		11	纱中横 TM8094B T=1.4 1.152kg/m		20	固定勾企 TM8547 1.187kg/m	
3	边框 TM8091D T=1.4 1.985kg/m		12	纱窗压线 TM8095 T=1 0.173kg/m		21	压座 TM8548 0.26kg/m	
4	边框 TM8091E T=1.4 2.125kg/m		13	框压线 TM8095A T=1 0.226kg/m		22	压线 TM8549 0.135kg/m	
5	下滑 TM8091 T=1.4 0.687kg/m		14	勾企盖板 TM8097 T=1.2 0.46kg/m		23	滑道槽 TM120B62G T=1.2 0.163kg/m	
6	下滑 TM8091C T=1.4 0.983kg/m		15	勾企盖板 TM8097A T=1.2 0.751kg/m		24	滑道槽 TM120B62H T=1.2 0.171kg/m	
7	中框 TM8092 T=1.4 1.404kg/m		16	收口 TM8098 T=1.2 0.28kg/m		25	边框 TM8091G T=1.9 1.552kg/m	
8	中框 TM8092A T=1.4 2.062kg/m		17	封盖 JMGR100088C T=1.2 0.097kg/m		26	边框 TM8091H T=1.9 2.294kg/m	
9	扇料 TM8094 T=1.4 1.155kg/m		18	滑道头 TM120B62 T=1.2 0.146kg/m		27	中框 TM8091J T=1.4 2.263kg/m	

图中所示型材截面、装配、编号、尺寸及重量仅供参考。如有疑问，请向本公司查询。
Information above just for your reference. Please contact us if you have any questions, Thank you!

图中所示型材截面、装配、编号、尺寸及重量仅供参考。如有疑问，请向本公司查询。
Information above just for your reference. Please contact us if you have any questions, Thank you!

序号 S/N	型号理论重量 JMA Code & KG/M	型材图 Drawing	序号 S/N	型号理论重量 JMA Code & KG/M	型材图 Drawing	序号 S/N	型号理论重量 JMA Code & KG/M	型材图 Drawing
28	中框 TM8091K T=1.4 1.665kg/m		37	收口 TM8098A T=1.2 0.287kg/m		46		
29	扇料 TM8094D T=1.9 1.348kg/m	勾企配TM8097B 收口配TM8098 	38	封盖 GR19018A T=1.0 0.090kg/m		47		
30	扇料 TM8094E T=1.4 1.146kg/m	勾企配TM8097, TM8097A 收口配TM8098 	39	角码 JMCW03637 2.933kg/m		48		
31	扇料 TM8094F T=1.4 1.166kg/m	勾企配TM8097C 收口配TM8098A 	40			49		
32	扇料 TM8094G T=2.0 0.910kg/m	勾企配TM8097D 收口配TM8098A 	41			50		
33	纱扇 TM8094H T=1.4 1.197kg/m	勾企配TM8097C 收口配TM8098A 压线配TM8095 开L13.0 	42			51		
34	勾企扣板 TM8097B T=1.2 0.444kg/m	封盖JMGR10008SC 	43			52		
35	勾企扣板 TM8097C T=1.2 0.446kg/m	封盖GR19018A 	44			53		
36	勾企扣板 TM8097D T=1.2 0.348kg/m	封盖GR19018A 	45			54		

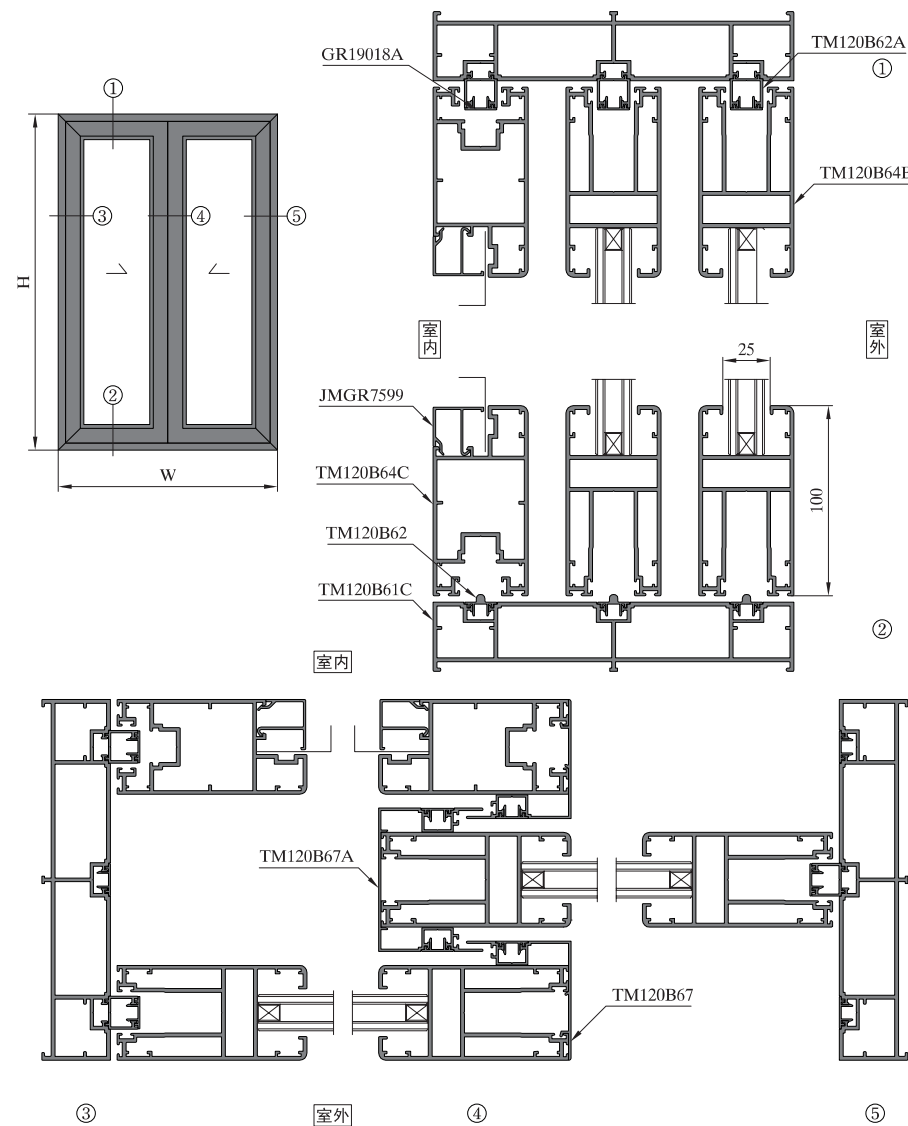

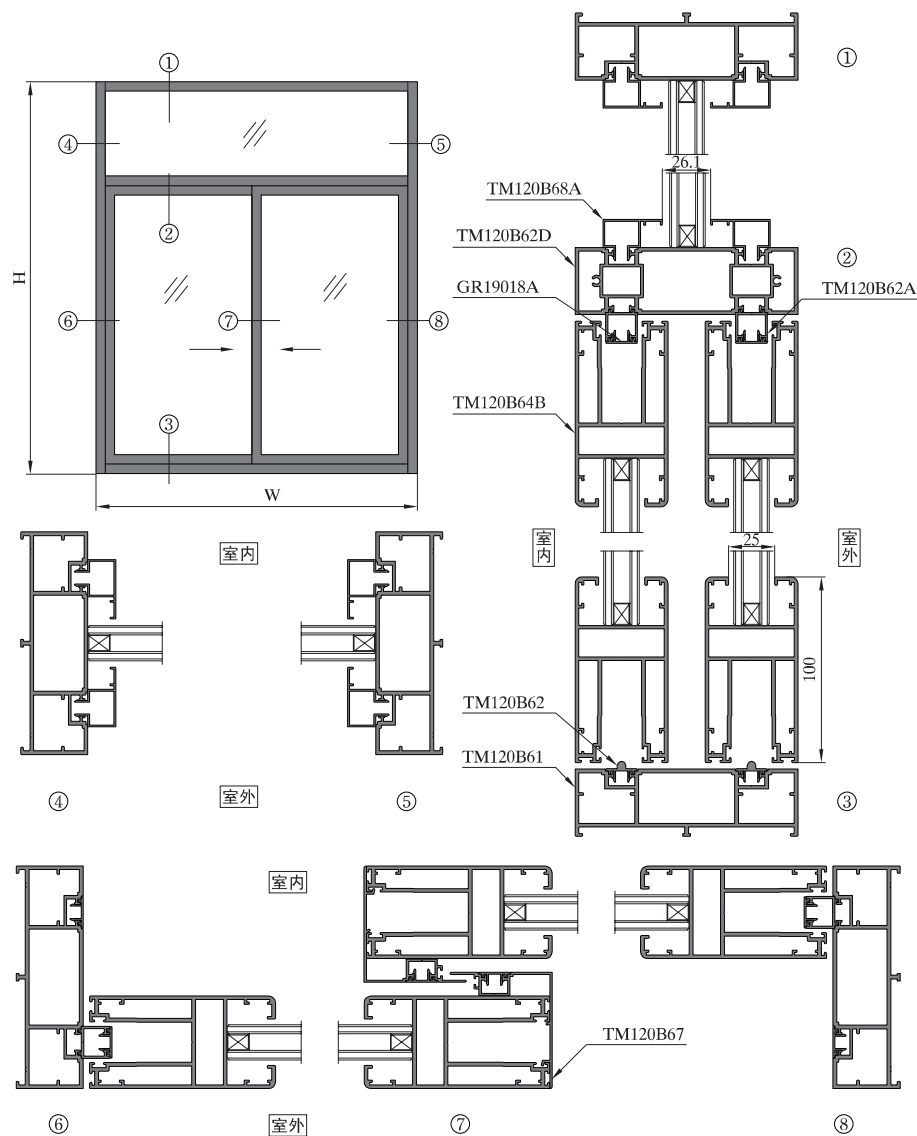

序号 S/N	型号理论重量 JMA Code & KG/M	型材图 Drawing	序号 S/N	型号理论重量 JMA Code & KG/M	型材图 Drawing	序号 S/N	型号理论重量 JMA Code & KG/M	型材图 Drawing
1	边框 TM120B61 T=2.0 2.319kg/m		7	轨道 TM120B62 T=1.2 0.146kg/m		15	纱扇 TM120B64D T=2.0 2.2kg/m	
2	边框 TM120B61C T=2.0 3.359kg/m		8	轨道槽 TM120B62A T=1.2 0.205kg/m		16	纱扇 TM120B64C T=2.0 2.411kg/m	
			9	中框 TM120B62D T=2.0 2.65kg/m		17	纱中横 TM120B64F T=2.0 1.842kg/m	
3	边框 TM120B61D T=2.0 2.486kg/m		10	中框 TM120B62C T=2.0 3.601kg/m		18	纱窗压线 JMGR7599 T=1.2 0.299kg/m	
4	边框 TM120B61E T=2.0 3.527kg/m					19	勾企盖板 TM120B67B T=1.2 0.536kg/m	
			11	扇料 TM120B64A T=2.0 2.118kg/m		20	勾企盖板 TM120B67 T=1.2 0.567kg/m	
5	下轨 TM120B61B T=2.0 1.723kg/m		12	扇料 TM120B64 T=2.0 2.376kg/m		21	勾企盖板 TM120B67D T=1.2 0.62kg/m	
			13	扇料 TM120B64B T=2.0 2.719kg/m		22	双勾企盖板 TM120B67C T=1.2 0.86kg/m	
6	下轨 TM120B61A T=2.0 1.238kg/m		14	扇料 TM120B64E T=2.5 3.745kg/m		23	双勾企盖板 TM120B67A T=1.2 0.923kg/m	

序号 S/N	型号理论重量 JMA Code & KG/M	型材图 Drawing	序号 S/N	型号理论重量 JMA Code & KG/M	型材图 Drawing	序号 S/N	型号理论重量 JMA Code & KG/M	型材图 Drawing
24	收口 TM120B68 T=1.2 0.346kg/m		33	中框 TM120B61K T=2.0 3.526kg/m		41	纱扇 TM120B64L T=1.60 1.866kg/m	
25	滑轮槽 TM120B68B T=1.6 0.427kg/m					42	纱中横 TM120B64M T=1.60 1.527kg/m	
26	压线 TM120B68A T=1.0 0.259kg/m		34	中框 TM120B61L T=2.0 2.457kg/m		43	扇料 TM120B64N T=3.0 1.818kg/m	
27	隔条 TM120B68C T=1.0 0.185kg/m		35	轨道槽 TM120B62G T=1.20 0.163kg/m		44	勾企扣板 TM120B67E T=1.2 0.451kg/m	
28	封盖 GR19018A T=1.0 0.09kg/m		36	轨道槽 TM120B62H T=1.20 0.171kg/m		45	辅料 TM120B69E T=1.4 0.408kg/m	
29	插板 TM120B69A T=1.2 0.968kg/m		37	扇料 TM120B64G T=2.0 2.319kg/m		46	连接件 TM120B69D T=1.0 0.168kg/m	
30	连接件 TM120B69B T=1.0 0.173kg/m		38	扇料 TM120B64H T=1.60 2.009kg/m		47	副框 GR19018 T=2.0 1.103kg/m	
31	连接件 TM120B69C T=1.0 0.187kg/m		39	扇料 TM120B64J T=1.60 1.799kg/m		48		
32	装饰线 TM120B69 T=1.5 1.391kg/m		40	纱扇 TM120B64K T=1.60 2.035kg/m		49		

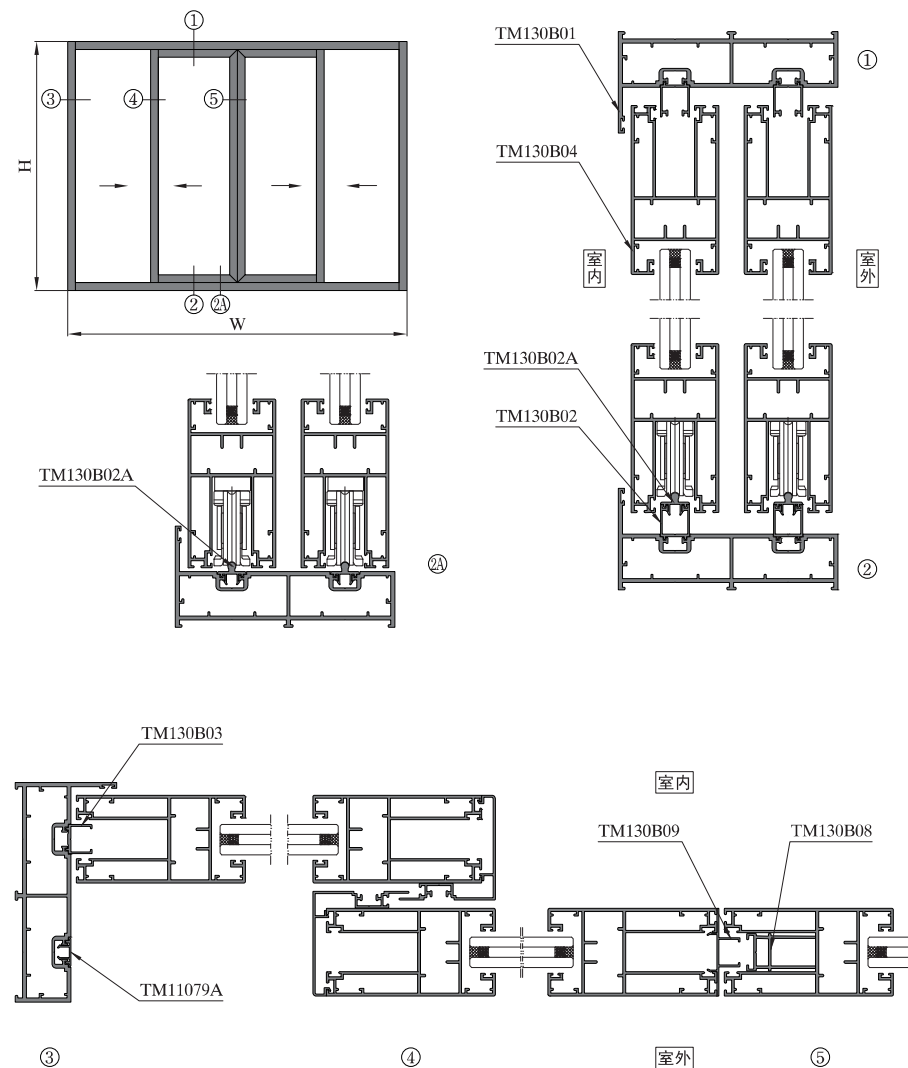

图中所示型材截面、装配、编号、尺寸及重量仅供参考。如有疑问，请向本公司查询。
Information above just for your reference. Please contact us if you have any questions, Thank you!

图中所示型材截面、装配、编号、尺寸及重量仅供参考。如有疑问，请向本公司查询。
Information above just for your reference. Please contact us if you have any questions, Thank you!

序号 S/N	型号理论重量 JMA Code & KG/M	型材图 Drawing	序号 S/N	型号理论重量 JMA Code & KG/M	型材图 Drawing	序号 S/N	型号理论重量 JMA Code & KG/M	型材图 Drawing
1	TM130B01 2.899kg/m		10	TM130B01B 3.207kg/m		19		
2	TM130B02 0.228kg/m		11	TM11079A 0.102kg/m		20		
3	TM130B02A 0.178kg/m		12			21		
4	TM130B03 0.177kg/m		13			22		
5	TM130B04 2.551kg/m		14			23		
6	TM130B07 0.626kg/m		15			24		
7	TM130B07A 0.975kg/m		16			25		
8	TM130B08 0.534kg/m		17			26		
9	TM130B09 0.294kg/m		18			27		

序号 S/N	型号理论重量 JMA Code & KG/M	型材图 Drawing	序号 S/N	型号理论重量 JMA Code & KG/M	型材图 Drawing	序号 S/N	型号理论重量 JMA Code & KG/M	型材图 Drawing
1	框料 TM130B01C T=2.0 1.391kg/m		10	收口 TM130B09A T=1.40 0.428kg/m		19		
2	滑轨 TM130B03A T=1.20 0.202kg/m		11	滑轨 TM130B09B T=1.60 0.323kg/m		20		
3	扇料 TM130B04C T=1.85 2.388kg/m		12	盖板 TM130B09C T=1.0 0.100kg/m		21		
4	扇料 TM130B04D T=1.80 2.251kg/m		13	辅料 TM130B09D T=1.40 0.347kg/m		22		
5	扇料 TM130B04E T=2.20 2.595kg/m		14			23		
6	勾企扣条 TM130B07B T=1.30 0.666kg/m		15			24		
7	包边 TM130B08A T=1.20 1.394kg/m		16			25		
8	包边 TM130B08B T=1.20 0.195kg/m		17			26		
9	锁槽 TM130B08C T=1.50 0.549kg/m		18			27		

图中所示型材截面、装配、编号、尺寸及重量仅供参考。如有疑问，请向本公司查询。
 Information above just for your reference. Please contact us if you have any questions, Thank you!

图中所示型材截面、装配、编号、尺寸及重量仅供参考。如有疑问，请向本公司查询。
 Information above just for your reference. Please contact us if you have any questions, Thank you!

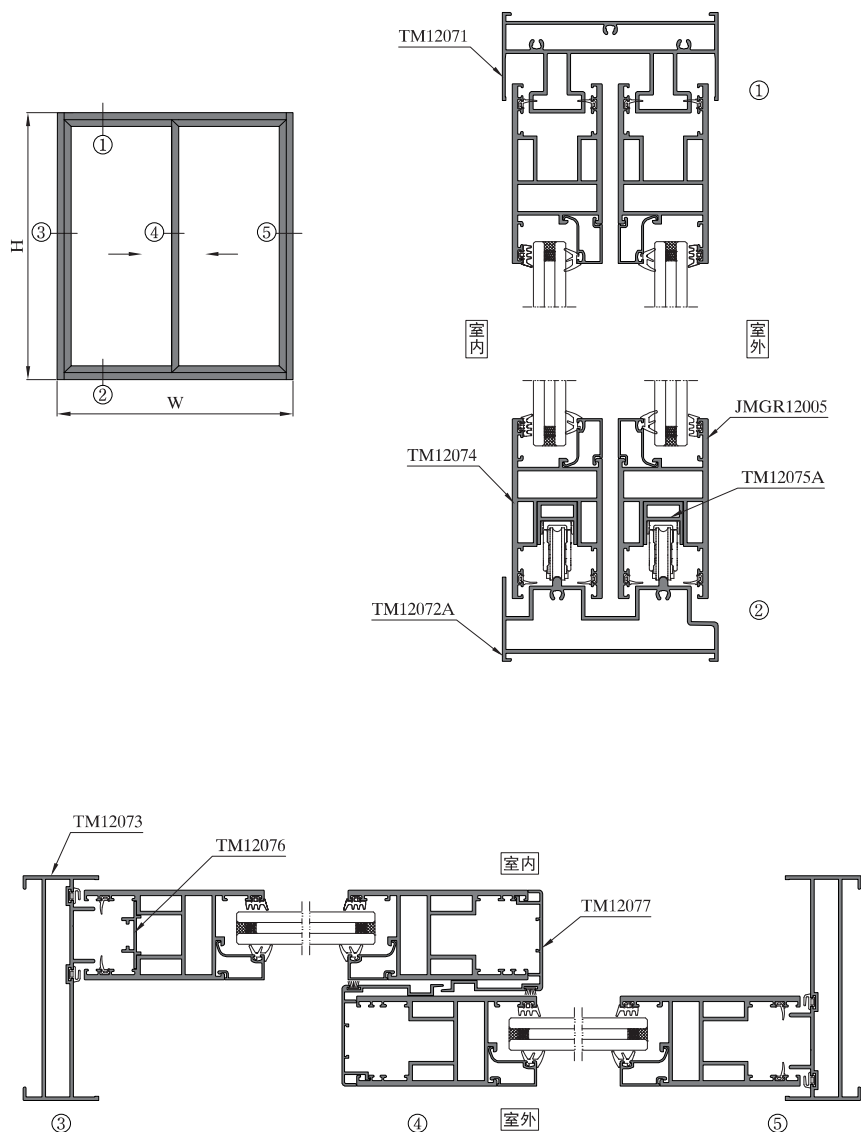

序号 S/N	型号理论重量 JMA Code & KG/M	型材图 Drawing	序号 S/N	型号理论重量 JMA Code & KG/M	型材图 Drawing	序号 S/N	型号理论重量 JMA Code & KG/M	型材图 Drawing
1	上滑 TM12071 3.236kg/m		10	锁槽 TM12076 0.262kg/m		19	压线 JMGR12005C 0.231kg/m	
2	固定上滑 TM12071A 3.392kg/m		11	勾企扣条 TM12077 0.683kg/m		20	压线 JMGR12005F 0.315kg/m	
3	下滑 TM12072 2.305kg/m		12	收口 TM12078 0.553kg/m		21	90° 转角 TC12518B 2.372kg/m	
4	下滑 TM12072A 2.457kg/m		13	上固 TM12079 1.969kg/m		22	收口 TM12078A 0.422kg/m	
5	边封 TM12073 2.131kg/m		14	边封插板 TM12079A 0.946kg/m		23	边封插板 TM12079D 0.918kg/m	
6	扇料 TM12074 2.689kg/m		15	中挺 TM12079B 2.32kg/m		24	锁槽 TM12079F 0.637kg/m	
7	滑轮槽 TM12075 0.565kg/m		16	压线 JMGR12005 0.261kg/m		25	压线 JMGR12005D 0.260kg/m	
8	滑轮槽 TM12075A 0.471kg/m		17	压线 JMGR12005A 0.22kg/m		26	压线 JMGR12005E 0.252kg/m	
9	滑轮槽 TM12075B 0.825kg/m		18	压线 JMGR12005B 0.238kg/m		27	压线 JMGR12005H 0.191kg/m	

图中所示型材截面、装配、编号、尺寸及重量仅供参考。如有疑问，请向本公司查询。
Information above just for your reference. Please contact us if you have any questions, Thank you!

图中所示型材截面、装配、编号、尺寸及重量仅供参考。如有疑问，请向本公司查询。
Information above just for your reference. Please contact us if you have any questions, Thank you!

序号 S/N	型号理论重量 JMA Code & KG/M	型材图 Drawing	序号 S/N	型号理论重量 JMA Code & KG/M	型材图 Drawing	序号 S/N	型号理论重量 JMA Code & KG/M	型材图 Drawing
1	下滑 TM12072E T=2.0 2.785kg/m		10	光企扣条 TM12077D T=1.50 0.660kg/m		19		
2	下滑 TM12072F T=2.0 2.548kg/m		11			20		
3	下滑 TM12072G T=2.0 2.873kg/m		12			21		
4	边封 TM12073A T=2.0 2.097kg/m		13			22		
5	扇料 TM12074B T=2.0 2.447kg/m		14			23		
6	扇料 TM12074D T=2.0 2.115kg/m		15			24		
7	扇料 TM12074E T=2.0 2.040kg/m		16			25		
8	锁槽 TM12075C T=1.60 0.634kg/m		17			26		
9	光企扣条 TM12077A T=1.50 0.686kg/m		18			27		

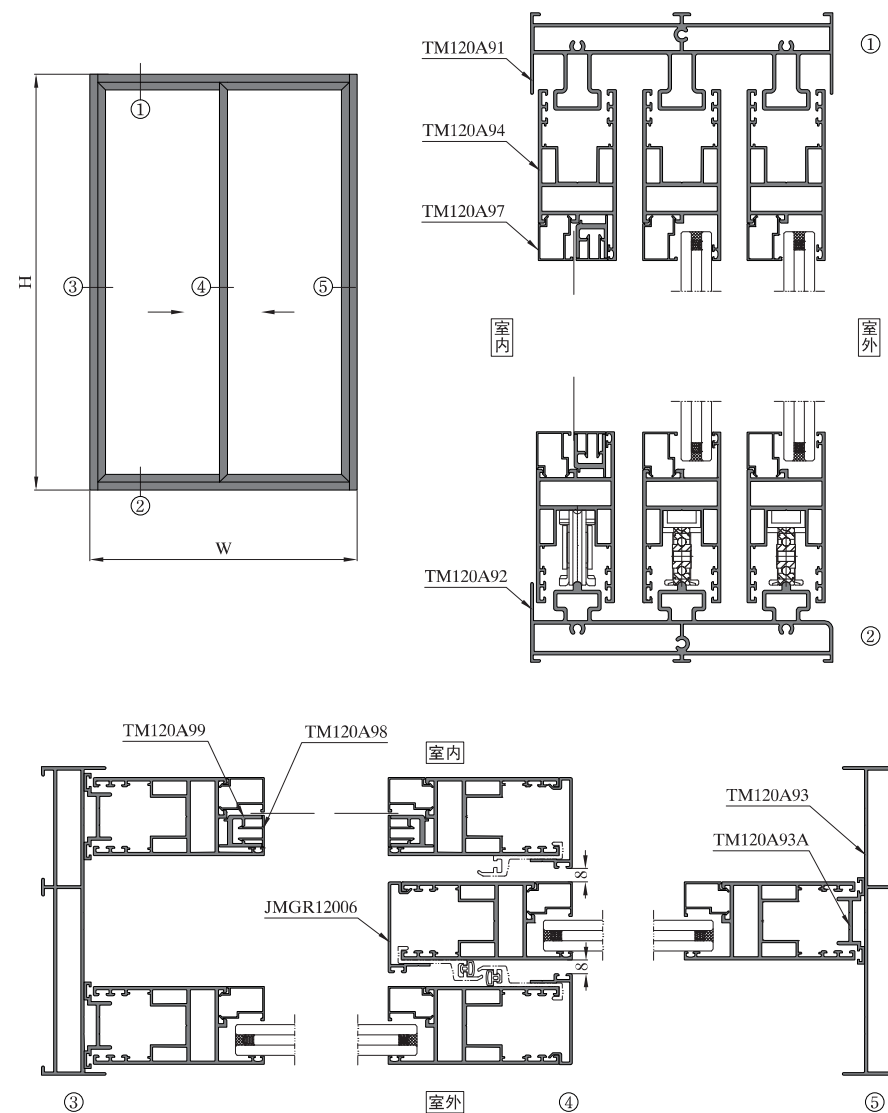

序号 S/N	型号理论重量 JMA Code & KG/M	型材图 Drawing	序号 S/N	型号理论重量 JMA Code & KG/M	型材图 Drawing	序号 S/N	型号理论重量 JMA Code & KG/M	型材图 Drawing
1	上滑 TM120A91 4.669kg/m		10	TM120A99 0.416kg/m		19		
2	下滑 TM120A92 4.251kg/m		11			20		
3	边封 TM120A93 2.675kg/m		12			21		
4	TM120A93A 0.469kg/m		13			22		
5	扇料 TM120A94 2.070kg/m		14			23		
6	勾企 JMGR12006 0.437kg/m		15			24		
7	扇压线 TM120A97 0.237kg/m		16			25		
8	TM120A97A 0.184kg/m		17			26		
9	TM120A98 0.150kg/m		18			27		

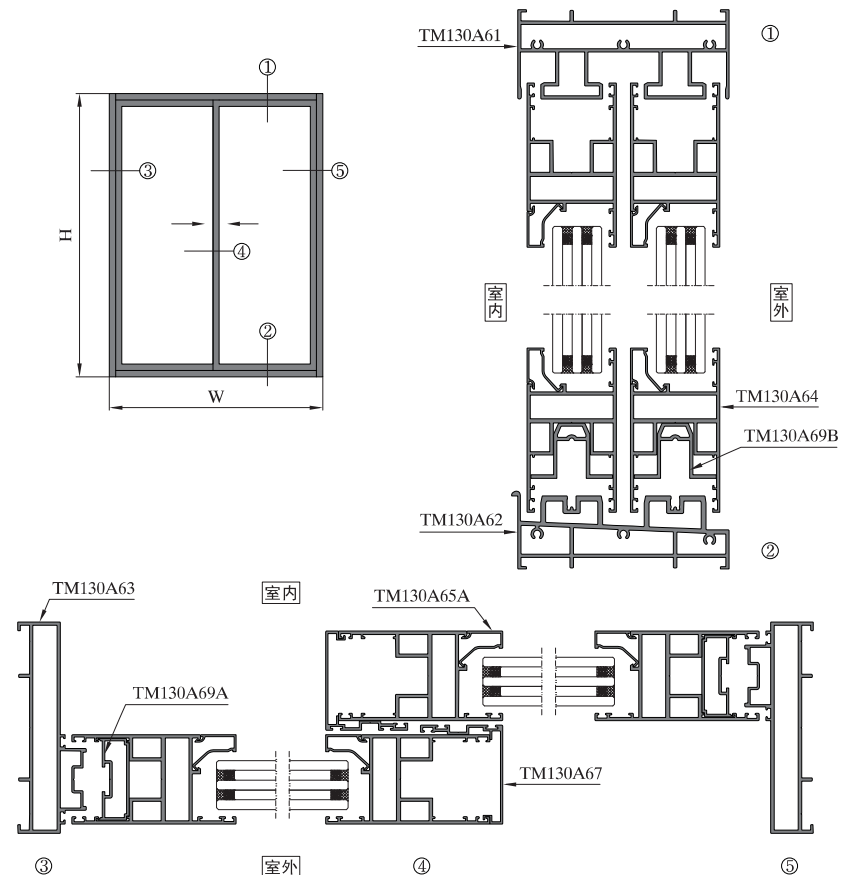

序号 S/N	型号理论重量 JMA Code & KG/M	型材图 Drawing	序号 S/N	型号理论重量 JMA Code & KG/M	型材图 Drawing	序号 S/N	型号理论重量 JMA Code & KG/M	型材图 Drawing
1	TM130A61 3.610kg/m		10	TM130A69B 0.766kg/m		19		
2	TM130A62 3.982kg/m		11	GRC7208A 2.727kg/m		20		
3	TM130A63 2.267kg/m		12			21		
4	TM130A63A 1.886kg/m		13			22		
5	TM130A64 2.241kg/m		14			23		
6	TM130A65A 0.245kg/m		15			24		
7	TM130A67 0.626kg/m		16			25		
8	TM130A68 0.627kg/m		17			26		
9	TM130A69A 0.636kg/m		18			27		

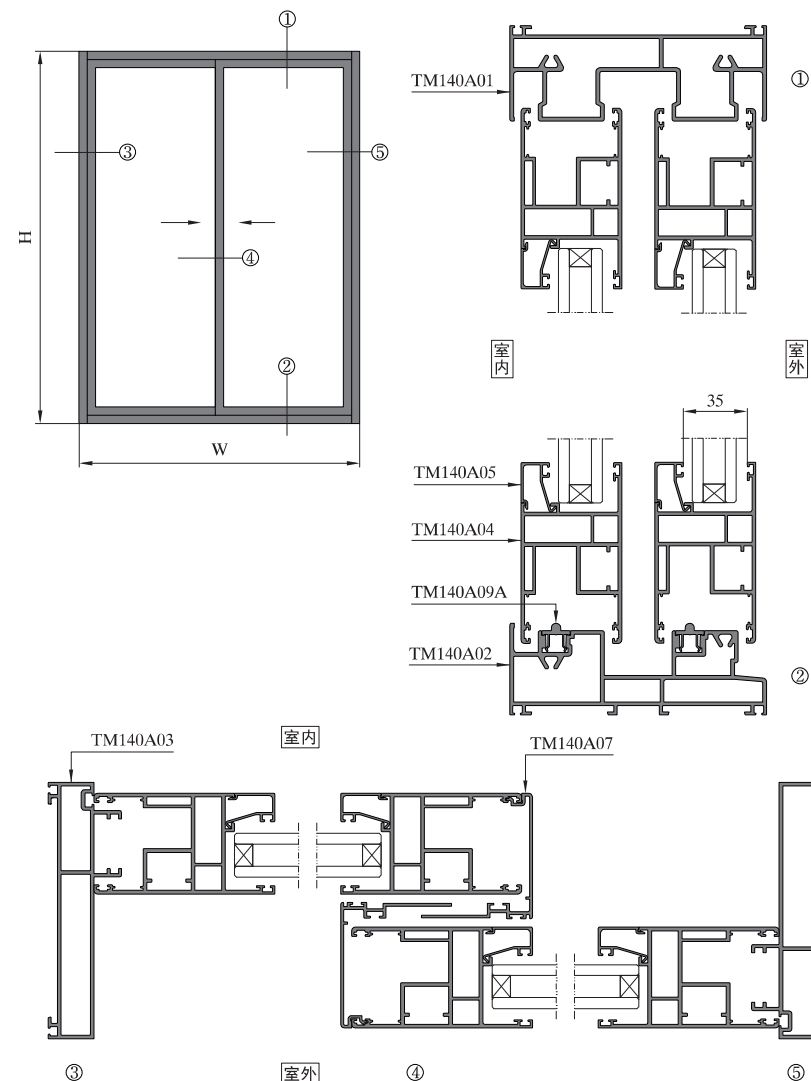

图中所示型材截面、装配、编号、尺寸及重量仅供参考。如有疑问，请向本公司查询。
Information above just for your reference. Please contact us if you have any questions, Thank you!

图中所示型材截面、装配、编号、尺寸及重量仅供参考。如有疑问，请向本公司查询。
Information above just for your reference. Please contact us if you have any questions, Thank you!

序号 S/N	型号理论重量 JMA Code & KG/M	型材图 Drawing	序号 S/N	型号理论重量 JMA Code & KG/M	型材图 Drawing	序号 S/N	型号理论重量 JMA Code & KG/M	型材图 Drawing
1	上滑 TM140A01 3.405kg/m		10			19		
2	下滑 TM140A02 3.457kg/m		11			20		
3	边封 TM140A03 2.321kg/m		12			21		
4	扇料 TM140A04 2.260kg/m		13			22		
5	扇料 TM140A05 0.260kg/m		14			23		
6	勾余盖板 TM140A07 0.744kg/m		15			24		
7	轨道 TM140A09A 0.195kg/m		16			25		
8	收口 TM140A09B 1.010kg/m		17			26		
9			18			27		

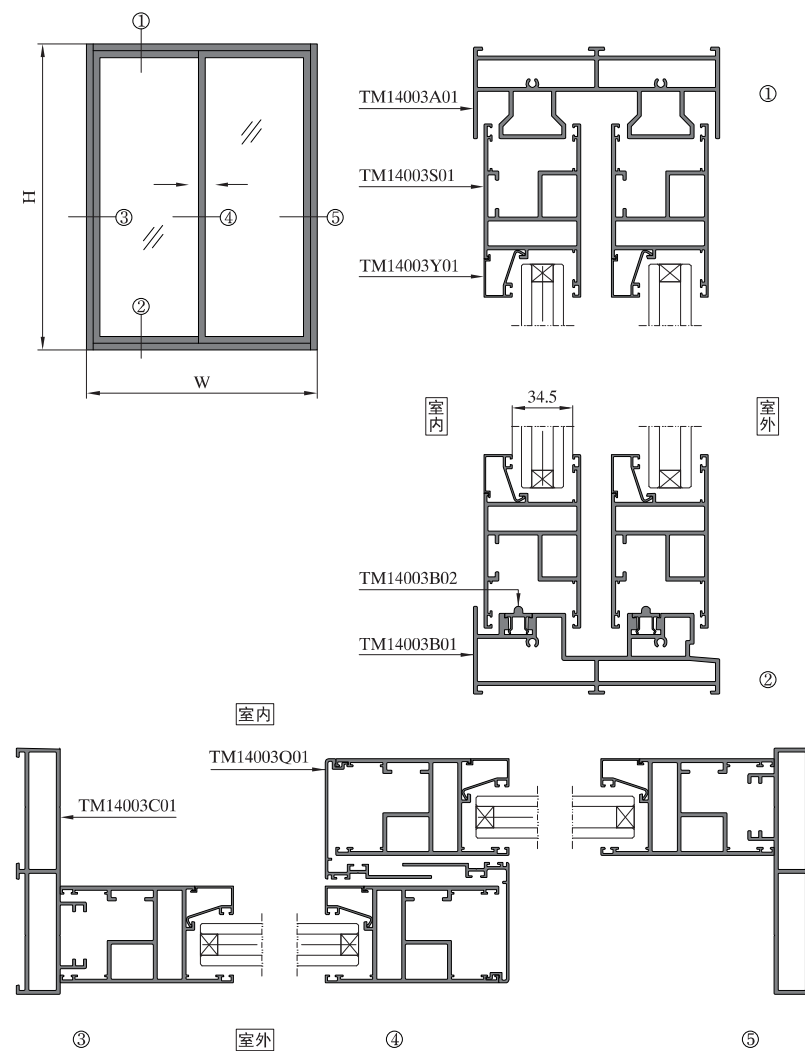

序号 S/N	型号理论重量 JMA Code & KG/M	型材图 Drawing	序号 S/N	型号理论重量 JMA Code & KG/M	型材图 Drawing	序号 S/N	型号理论重量 JMA Code & KG/M	型材图 Drawing
1	上滑 TM14003A01 3.893kg/m		10			19		
2	下滑 TM14003B01 3.651kg/m		11			20		
3	边封 TM14003C01 2.485kg/m		12			21		
4	扇料 TM14003S01 2.257kg/m		13			22		
5	压线 TM14003Y01 0.242kg/m		14			23		
6	压线 TM14003Y02 0.237kg/m		15			24		
7	勾企盖板 TM14003Q01 0.733kg/m		16			25		
8	轨道 TM14003B02 0.197kg/m		17			26		
9			18			27		

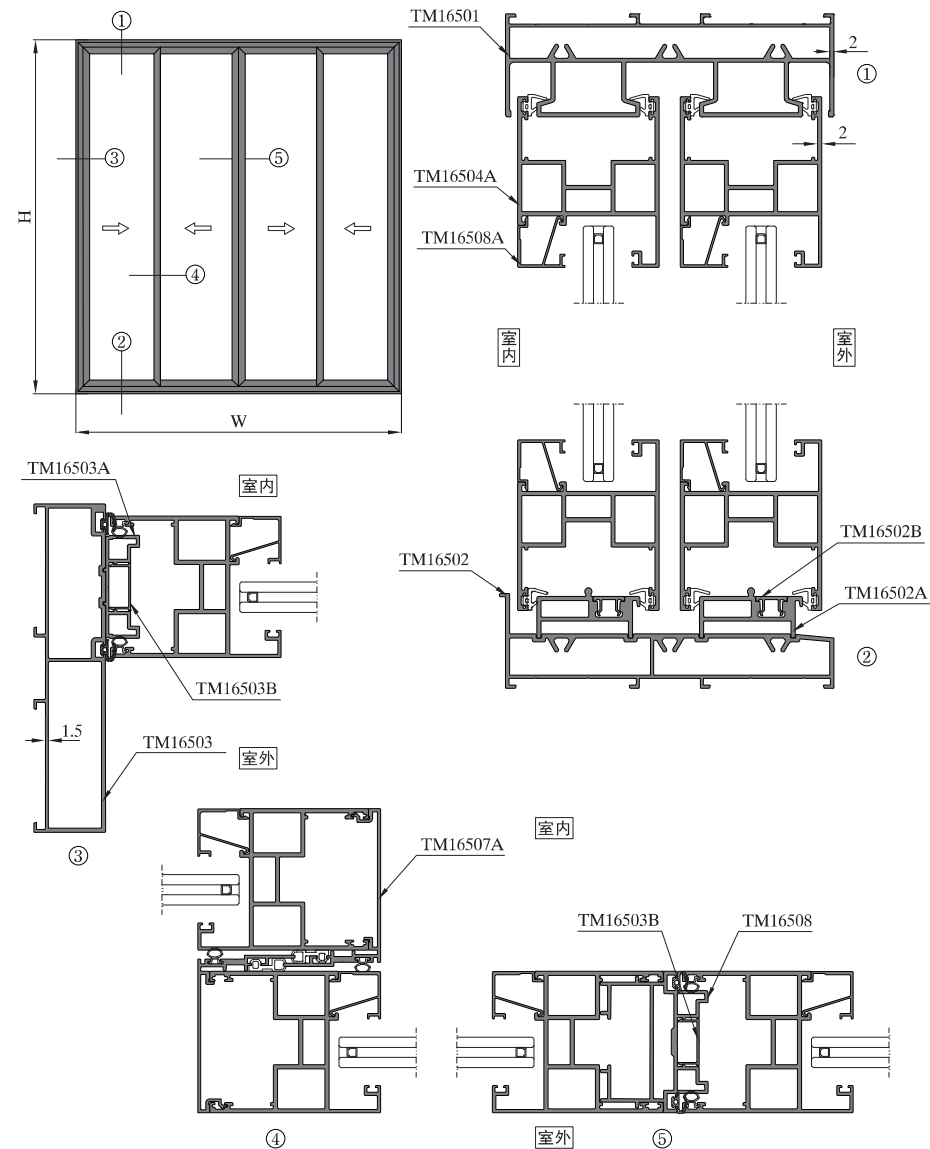

序号 S/N	型号理论重量 JMA Code & KG/M	型材图 Drawing	序号 S/N	型号理论重量 JMA Code & KG/M	型材图 Drawing	序号 S/N	型号理论重量 JMA Code & KG/M	型材图 Drawing
1	TM16501 3.928kg/m		10	TM16508 1.682kg/m		19		
2	TM16502 2.613kg/m		11	TM16508A 0.279kg/m		20		
3	TM16502A 0.909kg/m		12			21		
4	TM16502B 0.124kg/m		13			22		
5	TM16503 2.373kg/m		14			23		
6	TM16503A 0.646kg/m		15			24		
7	TM16503B 0.121kg/m		16			25		
8	TM16504A 2.118kg/m		17			26		
9	TM16507A 0.805kg/m		18			27		

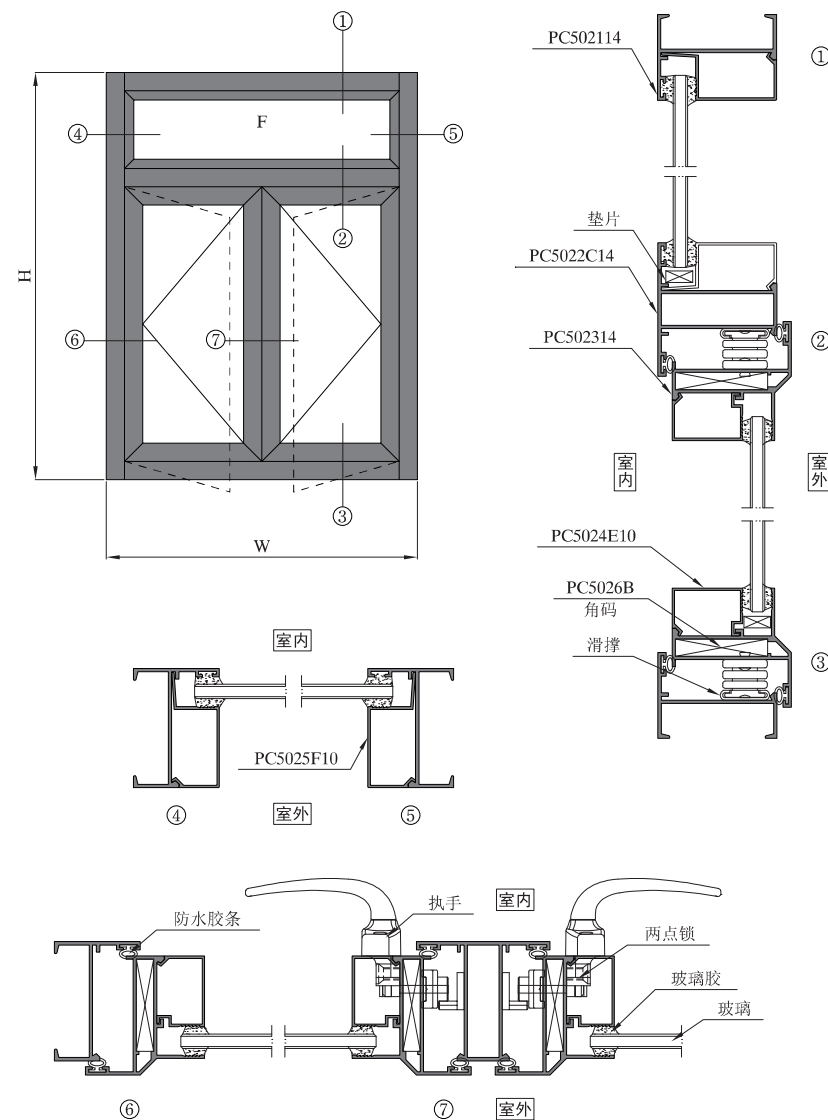

序号 S/N	型号理论重量 JMA Code & KG/M	型材图 Drawing	序号 S/N	型号理论重量 JMA Code & KG/M	型材图 Drawing	序号 S/N	型号理论重量 JMA Code & KG/M	型材图 Drawing
1	窗框 PC5021I14 0.491kg/m		10	窗框 PC5021R18 0.732kg/m		19	窗框 PC5021L17 1.296kg/m	
2	窗框 PC5021K14 0.596kg/m		11	窗框 PC5021E-B16 0.616kg/m	压线PC5025C10 	20	窗框 PC5021H16 1.043kg/m	角码JM4026A66
3	窗框 PC5021Q15 0.549kg/m		12	窗框 PC5021A14 0.541kg/m		21	窗框 PC5021P15 0.540kg/m	
4	窗框 PC5021E18 0.594kg/m	压线PC5025C10 	13	窗框 PC5021B14 0.543kg/m		22	窗框 PC5021C15 0.603kg/m	
5	窗框 PC5021F18 0.617kg/m	压线PC5025C10 	14	窗框 PC5021U15 0.610kg/m		23	窗框 PC5021T14 0.623kg/m	
6	窗框 PC5021D14 0.538kg/m		15	窗框 PC5021X14 0.541kg/m		24	窗框 PC5021W15 0.677kg/m	
7	窗框 PC5021I14 0.755kg/m	角码LT6019A 	16	窗框 PC5021E-A16 0.605kg/m	压线PC5025C10 	25	边框 PC5030F16 0.824kg/m	
8	窗框 PC5021Y18 0.966kg/m	角码PC5096A 	17	窗框 PC5021M16 0.640kg/m		26	边框 PC5030I16 0.872kg/m	
9	窗框 PC5021R14 0.606kg/m		18	窗框 PC5021G16 1.009kg/m	角码JM4026A66 	27	中挺 PC5022C14 0.796kg/m	

序号 S/N	型号理论重量 JMA Code & KG/M	型材图 Drawing	序号 S/N	型号理论重量 JMA Code & KG/M	型材图 Drawing	序号 S/N	型号理论重量 JMA Code & KG/M	型材图 Drawing
28	中挺 PC5022I14 0.899kg/m		37	中挺 PC5022D14 0.869kg/m		46	外开窗扇 PC5023I14 0.707kg/m	角码配PC5026B
29	中挺 PC5022Z18 1.084kg/m		38	中挺 PC5022N20 1.462kg/m		47	外开窗扇 PC5023A18 0.901kg/m	角码配PC5026B
30	中挺 PC5022E18 0.986kg/m		39	加强中挺 PC5022L14 1.182kg/m		48	外开窗扇 PC5023C18 0.880kg/m	角码配PC5026B
31	中挺 PC5022A14 0.845kg/m		40	中挺 PC5030A16 1.483kg/m		49	外开窗扇 PC5023Y 1.293kg/m	角码配E5055
32	中挺 PC5022A-A14 1.009kg/m		41	中挺 PC5030C25 2.060kg/m		50	扇压线 PC5024I10 0.242kg/m	开口7.6mm
33	中挺 PC5022B-B15 0.920kg/m		42	中挺 PC5030D40 2.976kg/m		51	扇压线 PC5024B10 0.205kg/m	开口19.6mm
34	中挺 PC5022G14 0.836kg/m		43	中挺 PC5030B16 1.535kg/m		52	扇压线 PC5024E10 0.216kg/m	开口11.9mm
35	中挺 PC5022F18 1.027kg/m	压线PC5025C10 	44	门中横 PC502920 1.857kg/m		53	扇压线 PC5024F 0.282kg/m	开口11.9mm
36	中挺 PC5022B14 0.892kg/m		45	门中横 PC5029A18 1.650kg/m		54	扇压线 PC5024D10 0.194kg/m	开口11.9mm

图中所示型材截面、装配、编号、尺寸及重量仅供参考。如有疑问，请向本公司查询。
Information above just for your reference. Please contact us if you have any questions, Thank you!

图中所示型材截面、装配、编号、尺寸及重量仅供参考。如有疑问，请向本公司查询。
Information above just for your reference. Please contact us if you have any questions, Thank you!

序号 S/N	型号理论重量 JMA Code & KG/M	型材图 Drawing	序号 S/N	型号理论重量 JMA Code & KG/M	型材图 Drawing	序号 S/N	型号理论重量 JMA Code & KG/M	型材图 Drawing
55	扇压线 PC5024G10 0.177kg/m	开口16mm 	64	框压线 PC5025C-B10 0.233kg/m	开口16mm 配PC5021E-A16 PC5022F18 	73	拼料 PC5027A17 0.831kg/m	
56	扇压线 PC5024A10 0.194kg/m	开口23.5mm 	65	框压线 PC5025D10 0.261kg/m	开口18mm 	74	拼料 PC5027F20 1.197kg/m	
57	扇压线 PC5024C10 0.178kg/m	开口23.5mm 	66	框压线 PC5025E10 0.264kg/m	开口23.5mm 	75	转角 PC5027B17 1.050kg/m	
58	框压线 PC502510 0.224kg/m	开口7.5mm 	67	框压线 PC5025A10 0.228kg/m	开口23.5mm 	76	转角 PC5027I16 1.089kg/m	
59	框压线 PC5025B10 0.232kg/m	开口12mm 	68	框压线 PC5025C-A10 0.248kg/m	开口23.5mm 配PC5021E-A16 PC5022F18 	77	转角 PC5027H17 1.248kg/m	
60	框压线 PC5025F10 0.265kg/m	开口12.5mm 	69	转换料 B-5014B12 0.402kg/m		78	转角 PC5027R14 0.823kg/m	
61	框压线 PC5025C10 0.232kg/m	开口12mm 配PC5021E-A16 PC5022F18 	70	拼料 PC5027E13 0.279kg/m		79	转角 PC5027C18 1.080kg/m	
62	框压线 PC5025G10 0.232kg/m	开口14mm 	71	拼料 PC5028A20 0.860kg/m		80	转角 PC5027G15 0.891kg/m	
63	框压线 PC5025H10 0.219kg/m	开口16mm 	72	拼料 PC502820 1.024kg/m		81	转角 PC5027D20 1.112kg/m	

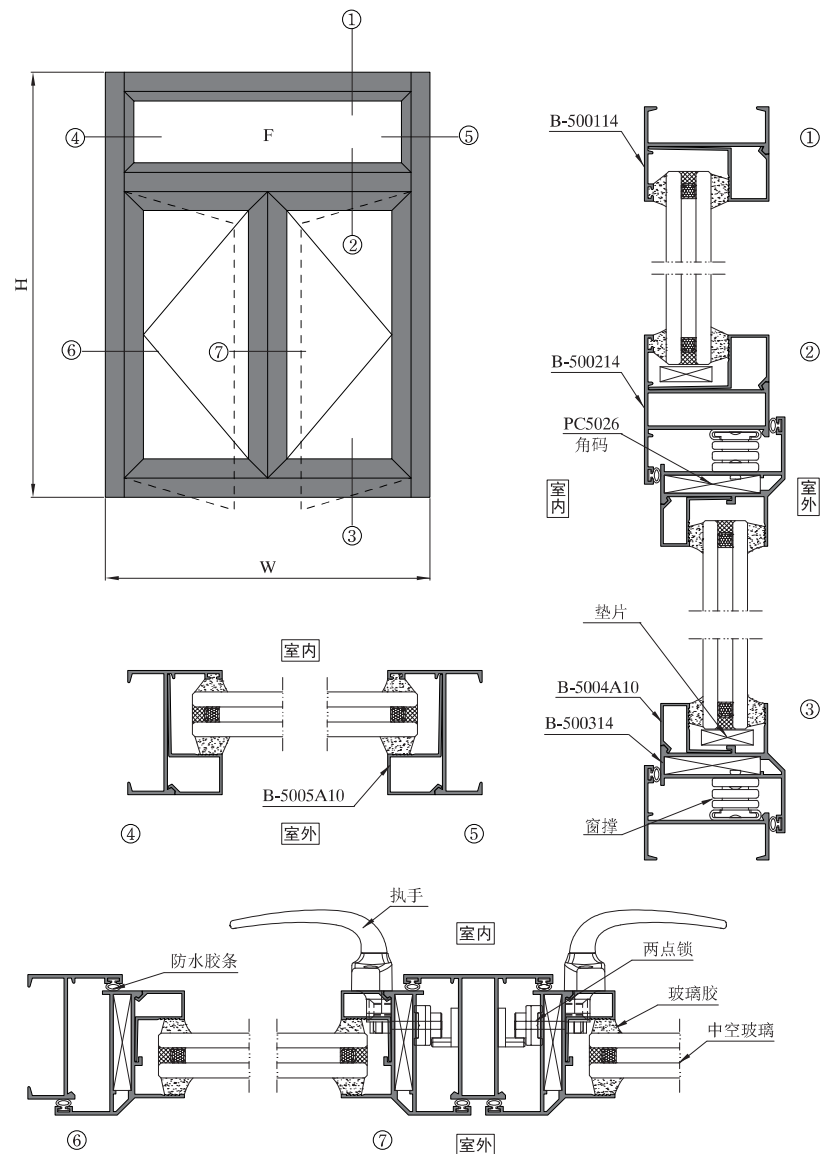

图中所示型材截面、装配、编号、尺寸及重量仅供参考。如有疑问，请向本公司查询。
Information above just for your reference. Please contact us if you have any questions, Thank you!

图中所示型材截面、装配、编号、尺寸及重量仅供参考。如有疑问，请向本公司查询。
Information above just for your reference. Please contact us if you have any questions, Thank you!



序号 S/N	型号理论重量 JMA Code & KG/M	型材图 Drawing	序号 S/N	型号理论重量 JMA Code & KG/M	型材图 Drawing	序号 S/N	型号理论重量 JMA Code & KG/M	型材图 Drawing
1	窗框 B-5001I14 0.491kg/m		10	窗框 B-5001H16 0.635kg/m		19	加强中挺 B-5002B16 1.253kg/m	
2	窗框 B-5001P14 0.564kg/m		11	窗框 B-5001F16 0.683kg/m		20	加强中挺 B-5002L14 1.034kg/m	
3	窗框 B-5001R14 0.527kg/m		12	窗框 B-5001G16 0.747kg/m		21	加强中挺 B-5002N15 1.153kg/m	
4	窗框 B-5001AE14 0.541kg/m		13	中挺 B-5002I14 0.797kg/m		22	转换框 B-5008I14 0.463kg/m	
5	窗框 B-5001BA14 0.743kg/m		14	中挺 B-5002K14 0.867kg/m		23	转换框 B-5001A14 0.783kg/m	
6	窗框 B-5001D14 0.534kg/m		15	中挺 B-5002M14 0.903kg/m		24	窗扇 B-5003I14 0.707kg/m	
7	窗框 B-5001E16 0.654kg/m		16	反中工 B-5002E14 0.796kg/m		25	窗扇 B-5003A16 1.004kg/m	
8	窗框 B-5001C14 1.081kg/m		17	中挺 B-5002A14 0.840kg/m		26	窗扇 B-5003F14 0.865kg/m	
9	窗框 B-5001K16 0.729kg/m		18	加强中挺 B-5002C14 1.089kg/m		27	窗扇 B-5003I14 0.791kg/m	

序号 S/N	型号理论重量 JMA Code & KG/M	型材图 Drawing	序号 S/N	型号理论重量 JMA Code & KG/M	型材图 Drawing	序号 S/N	型号理论重量 JMA Code & KG/M	型材图 Drawing
28	窗扇 B-5003L14 0.735kg/m		37	扇压线 B-5004B10 0.202kg/m		46	框压线 B-5005D10 0.265kg/m	
29	窗扇 B-5003N14 0.841kg/m		38	扇压线 B-5004D10 0.197kg/m		47	框压线 B-5005B10 0.268kg/m	
30	窗扇 B-5003M14 0.786kg/m		39	扇压线 B-5004E10 0.190kg/m		48	框压线 B-5005E10 0.256kg/m	
31	窗扇 B-5003K14 0.878kg/m		40	扇压线 B-5004A10 0.204kg/m		49	框压线 B-5005A10 0.274kg/m	
32	窗扇 B-5003R14 0.823kg/m		41	框压线 B-5005F10 0.308kg/m		50	转角 B-5009I16 1.560kg/m	
33	窗扇 B-5003G14 0.820kg/m		42	框压线 B-5004J10 0.232kg/m		51	转角 B-5009B15 1.150kg/m	
34	窗扇 B-5003P14 1.043kg/m		43	框压线 B-5004K10 0.233kg/m		52	拼料 B-5009C14 0.842kg/m	
35	扇压线 B-5004F10 0.237kg/m		44	框压线 B-5005C10 0.272kg/m		53		
36	扇压线 B-5004C10 0.206kg/m		45	框压线 B-5005I10 0.272kg/m		54		

图中所示型材截面、装配、编号、尺寸及重量仅供参考。如有疑问，请向本公司查询。
Information above just for your reference. Please contact us if you have any questions, Thank you!

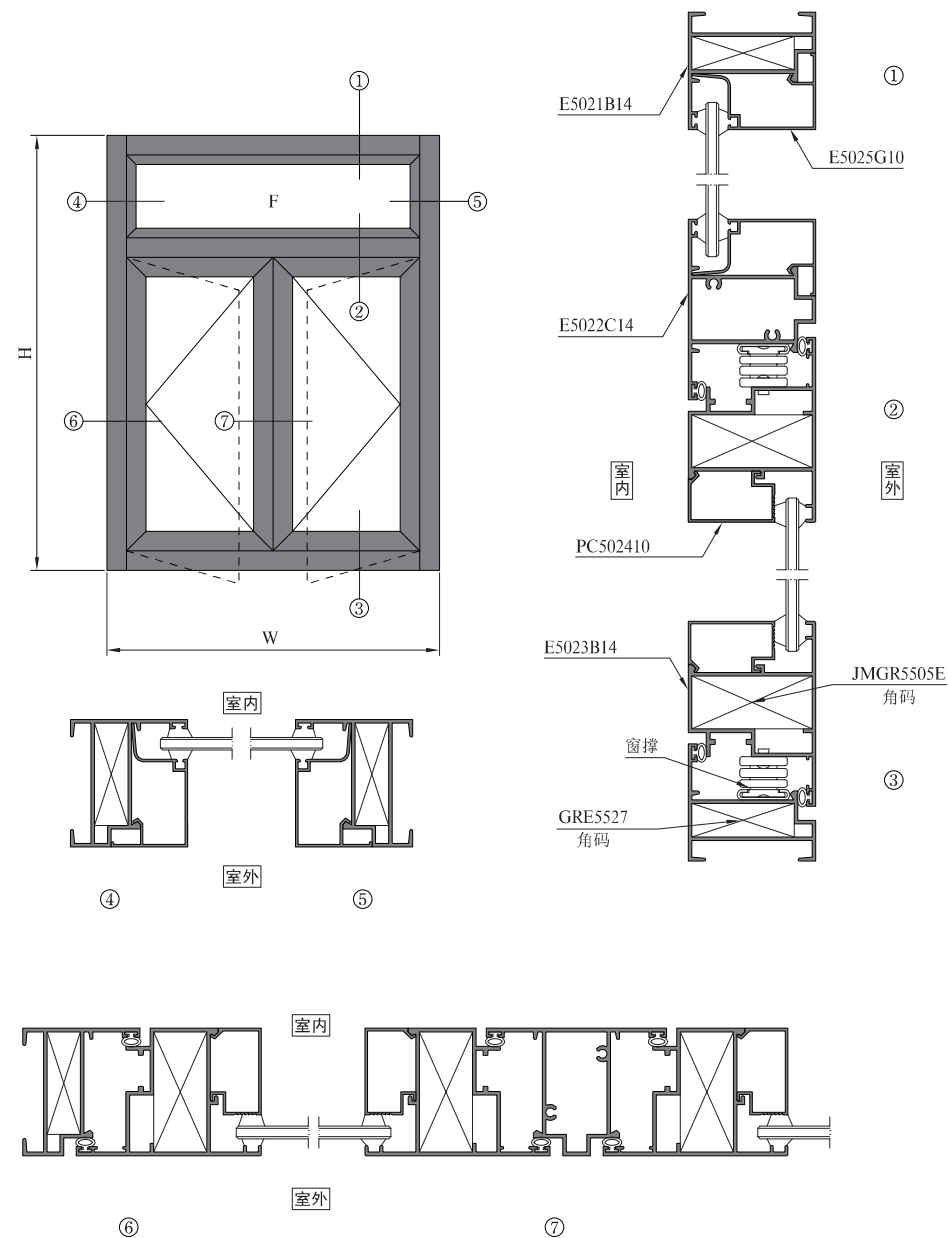
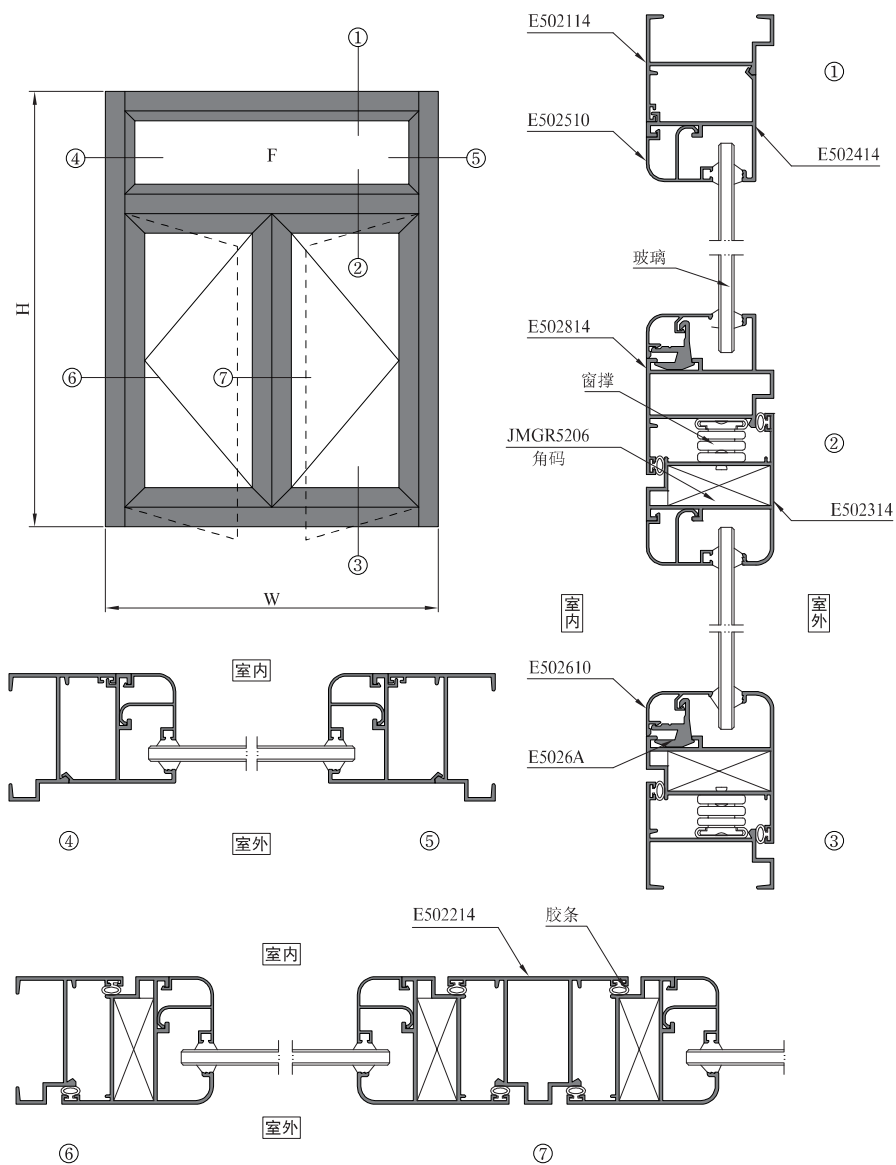
图中所示型材截面、装配、编号、尺寸及重量仅供参考。如有疑问，请向本公司查询。
Information above just for your reference. Please contact us if you have any questions, Thank you!

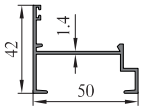
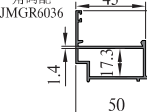
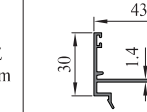
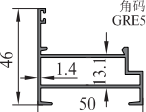
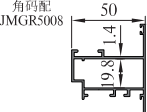
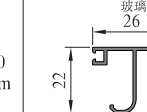
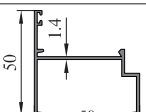
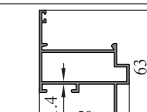
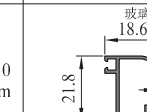
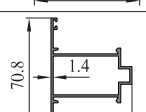
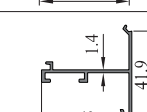
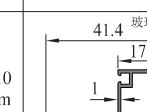
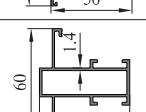
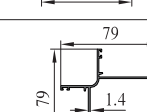
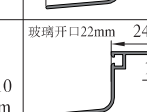
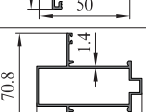
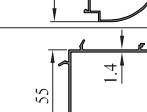
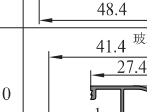
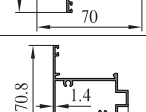
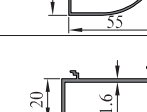

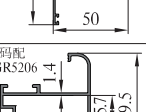
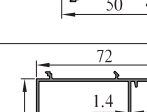
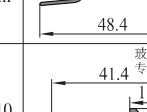
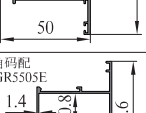
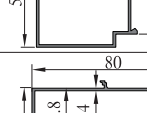
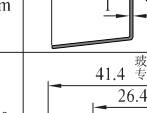
序号 S/N	型号理论重量 JMA Code & KG/M	型材图 Drawing	序号 S/N	型号理论重量 JMA Code & KG/M	型材图 Drawing	序号 S/N	型号理论重量 JMA Code & KG/M	型材图 Drawing
1	框料 E502114 0.546kg/m		10	扇料 E5023C14 0.779kg/m		19	转换料 E5027E 0.461kg/m	
2	框料 E5021B14 0.772kg/m		11	扇料 E5023D14 0.986kg/m		20	扇压线 E502510 0.249kg/m	
3	框料 E5021C14 0.611kg/m		12	扇料 E502814 0.875kg/m		21	扇压线 E5025B10 0.207kg/m	
4	中挺 E502214 0.897kg/m		13	转换料 E502414 0.472kg/m		22	框压线 E5025C10 0.247kg/m	
5	加强中挺 E5022A14 0.891kg/m		14	转角 E502714 1.123kg/m		23	框压线 E5025D10 0.332kg/m	
6	加强中挺 E5022B14 1.062kg/m		15	转角 E5027A14 0.903kg/m		24	框压线 E5025E10 0.269kg/m	
7	中挺 E5022C14 0.969kg/m		16	拼管 E5027B16 0.713kg/m		25	框压线 E5025G10 0.335kg/m	
8	扇料 E502314 0.853kg/m		17	转角 E5027C14 0.977kg/m		26	框压线 E5025H10 0.219kg/m	
9	扇料 E5023B14 0.985kg/m		18	转角 E5027D14 1.034kg/m		27	框压线 E5025J10 0.213kg/m	

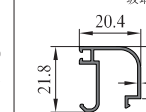
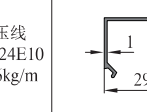
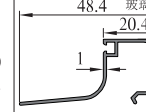
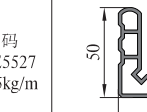
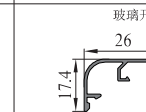
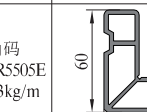
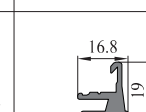
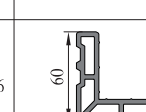
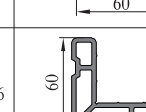
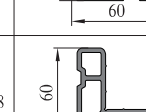
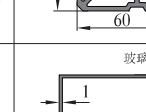
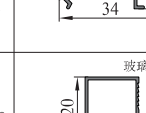
序号 S/N	型号理论重量 JMA Code & KG/M	型材图 Drawing	序号 S/N	型号理论重量 JMA Code & KG/M	型材图 Drawing	序号 S/N	型号理论重量 JMA Code & KG/M	型材图 Drawing
28	扇压线 E5025K10 0.218kg/m		37	扇压线 PC5024E10 0.216kg/m		46		
29	框压线 E5025N10 0.319kg/m		38	角码 GRE5527 1.315kg/m		47		
30	压线 E502610 0.163kg/m		39	角码 JMGR5505E 2.013kg/m		48		
31	压线座 E5026A 0.322kg/m		40			49		
32	角码 JMGR5206 2.351kg/m		41			50		
33	角码 JMGR6036 2.278kg/m		42			51		
34	角码 JMGR5008 2.351kg/m		43			52		
35	扇压线 PC502410 0.242kg/m		44			53		
36	扇压线 PC5024A10 0.194kg/m		45			54		

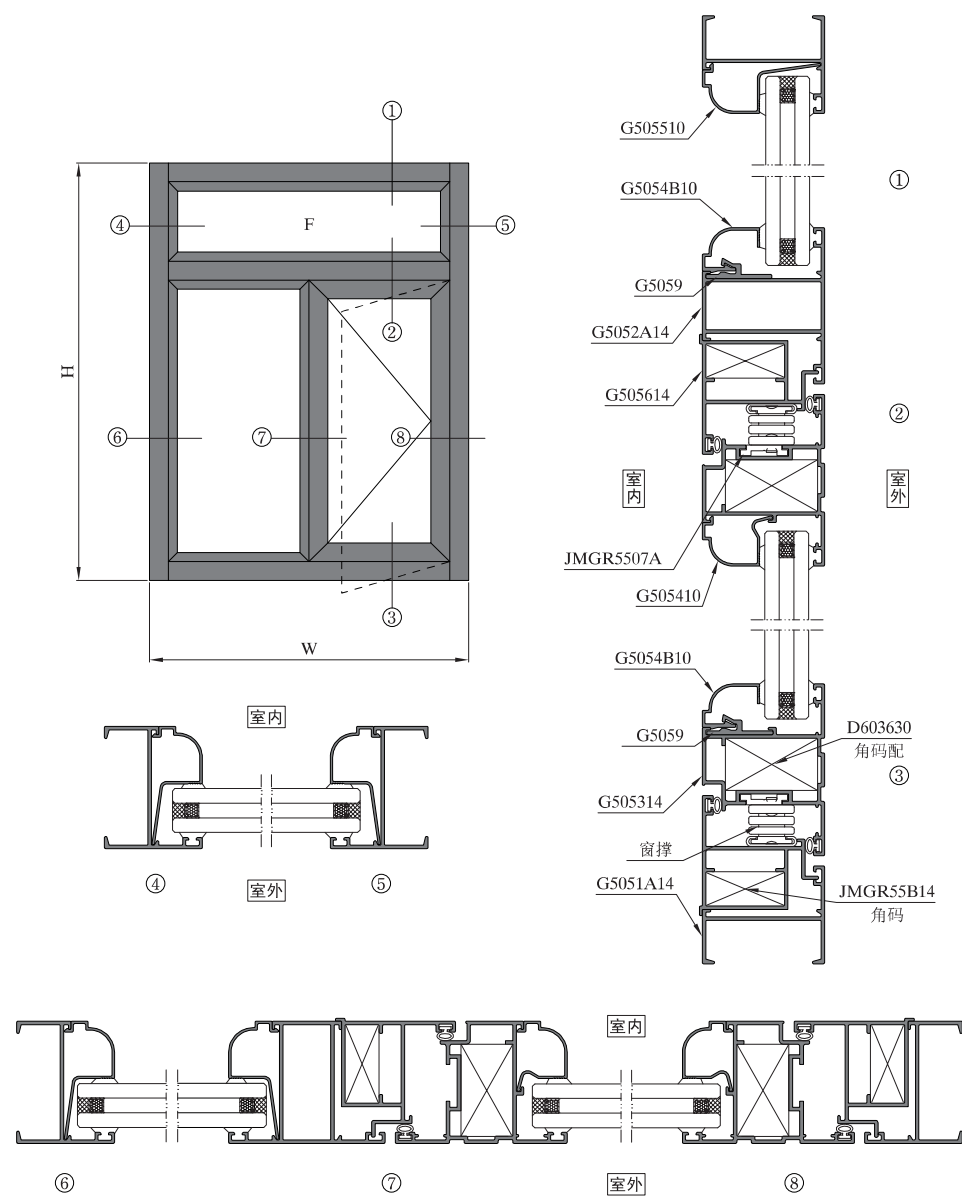
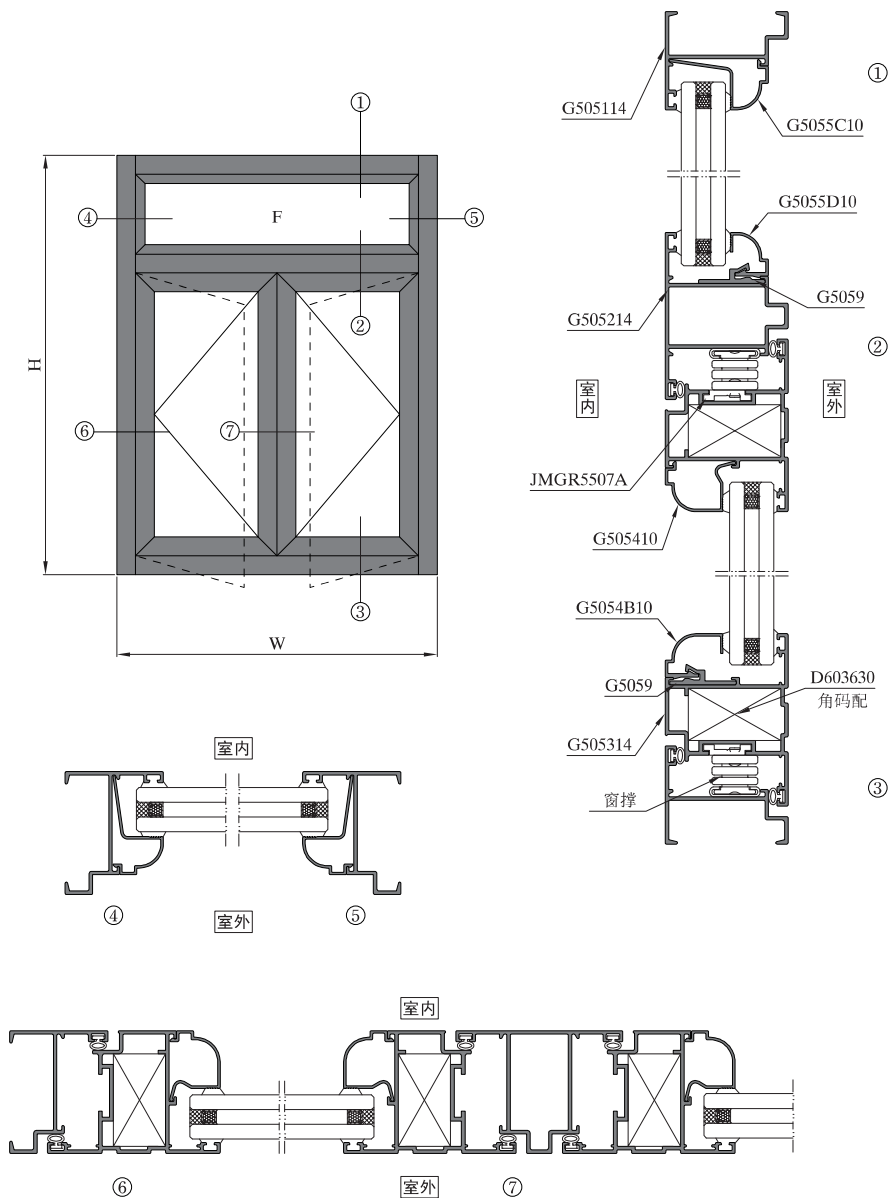

序号 S/N	型号理论重量 JMA Code & KG/M	型材图 Drawing	序号 S/N	型号理论重量 JMA Code & KG/M	型材图 Drawing	序号 S/N	型号理论重量 JMA Code & KG/M	型材图 Drawing
1	框料 G505114 0.515kg/m		10	扇料 G505314 1.003kg/m		19	压线 G5055C10 0.217kg/m	
2	框料 G5051A14 0.515kg/m		11	扇压线 G505410 0.197kg/m		20	压线 G5055D10 0.161kg/m	
3	框料 G5051B14 0.597kg/m		12	扇压线 G5054A10 0.247kg/m		21	转换料 G505614 0.748kg/m	
4	框料 G5051C14 0.769kg/m		13	压线 G5054B10 0.185kg/m		22	转角 G505714 1.035kg/m	
5	中挺 G505214 0.875kg/m		14	压线 G5054C11 0.233kg/m		23	压座 G505814 0.324kg/m	
6	中挺 G5052A14 0.842kg/m		15	压线 G5054E10 0.167kg/m		24	压座 G5058A14 0.283kg/m	
7	中挺 G5052B14 1.273kg/m		16	框压线 G505510 0.240kg/m		25	压线槽 G5059 0.194kg/m	
8	中挺 G5052C14 1.544kg/m		17	框压线 G5055A10 0.244kg/m		26	角码 D603630 2.343kg/m	
9	中挺 G5052D14 1.240kg/m		18	框压线 G5055B10 0.238kg/m		27	角码 JMGR55B14 3.347kg/m	

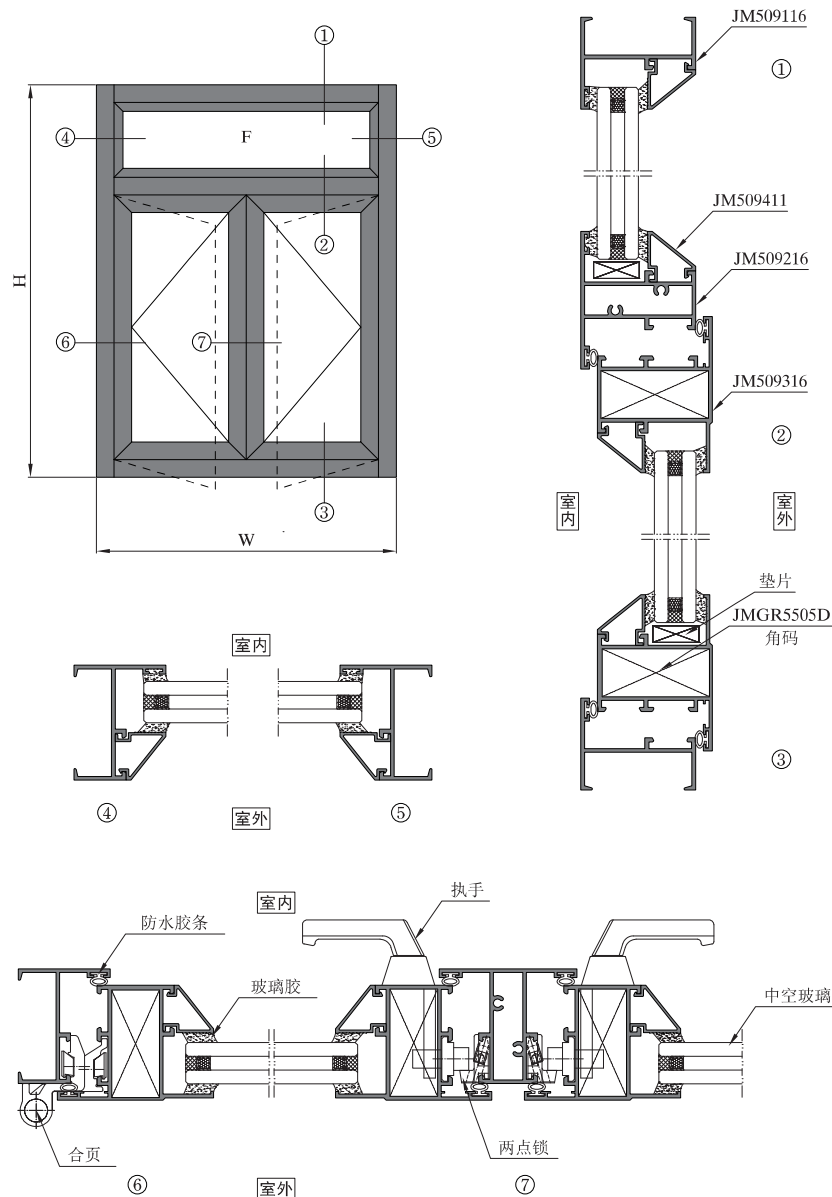

图中所示型材截面、装配、编号、尺寸及重量仅供参考。如有疑问，请向本公司查询。
Information above just for your reference. Please contact us if you have any questions, Thank you!

图中所示型材截面、装配、编号、尺寸及重量仅供参考。如有疑问，请向本公司查询。
Information above just for your reference. Please contact us if you have any questions, Thank you!

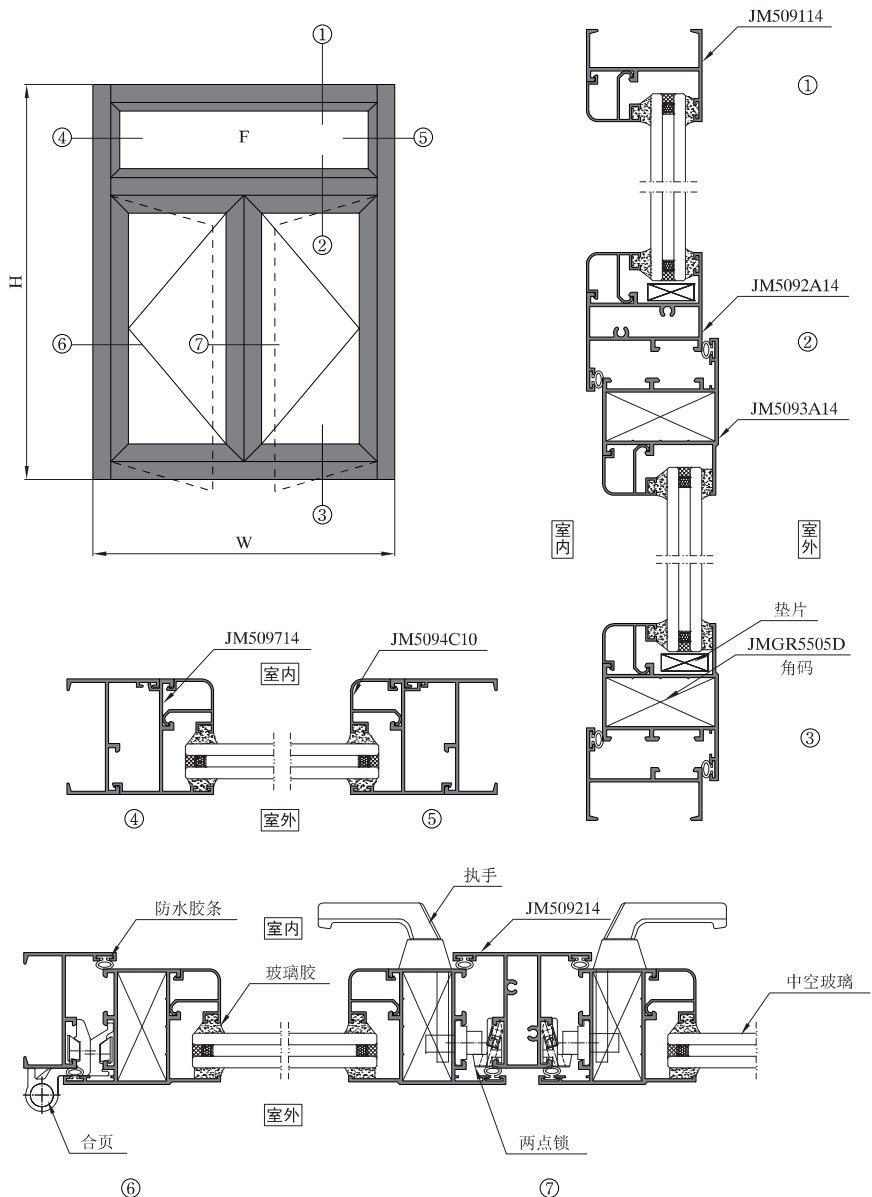

序号 S/N	型号理论重量 JMA Code & KG/M	型材图 Drawing	序号 S/N	型号理论重量 JMA Code & KG/M	型材图 Drawing	序号 S/N	型号理论重量 JMA Code & KG/M	型材图 Drawing
1	框料 JM509114 0.554kg/m		10	中挺 JM509216 1.066kg/m		19	扇料 JM5093A14 0.988kg/m	
2	框料 JM509116 0.612kg/m		11	中挺 JM5092A14 0.970kg/m		20	扇料 JM5093B20 1.457kg/m	
3	框料 JM509120 0.708kg/m		12	中挺 JM5092B14 1.461kg/m		21	扇料 JM5093D20 1.616kg/m	
4	框料 JM5091A14 0.636kg/m		13	中挺 JM5092C14 0.969kg/m		22	扇料 JM5093E20 1.501kg/m	
5	框料 JM5091A20 0.789kg/m		14	中挺 JM5092E14 1.013kg/m		23	扇料 JM5093F20 1.660kg/m	
6	框料 JM5091B14 0.788kg/m		15	中挺 JM5092D16 1.785kg/m		24	压线 JM509411 0.203kg/m	
7	框料 JM5091C14 0.829kg/m		16	中挺 JM5092F16 1.866kg/m		25	压线 JM5094A11 0.233kg/m	
8	框料 JM5091C20 1.095kg/m		17	中挺 JM5092G14 0.969kg/m		26	压线 JM5094B10 0.275kg/m	
9	中挺 JM509214 0.970kg/m		18	扇料 JM509316 1.084kg/m		27	压线 JM5094C10 0.246kg/m	

图中所示型材截面、装配、编号、尺寸及重量仅供参考。如有疑问，请向本公司查询。
Information above just for your reference. Please contact us if you have any questions, Thank you!

图中所示型材截面、装配、编号、尺寸及重量仅供参考。如有疑问，请向本公司查询。
Information above just for your reference. Please contact us if you have any questions, Thank you!



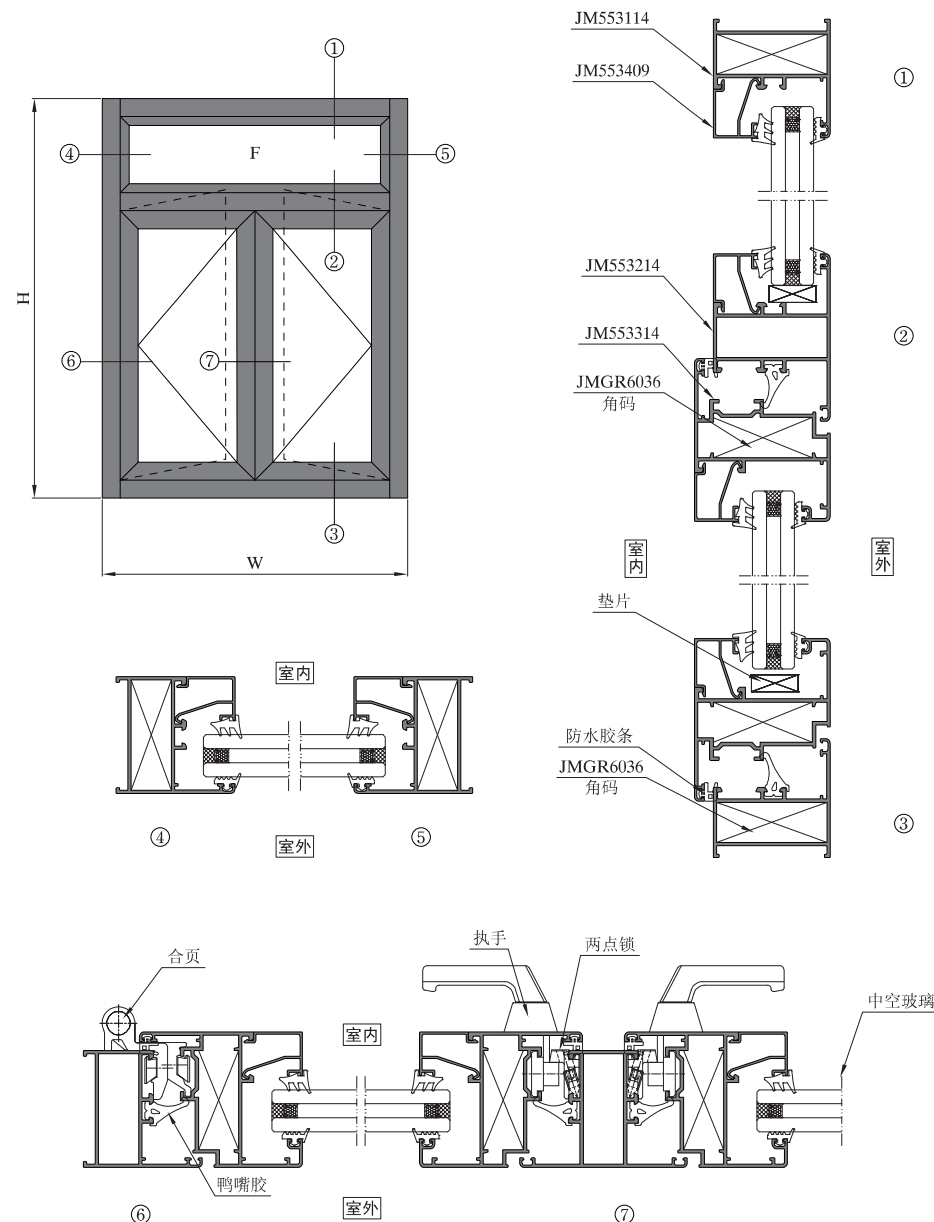

序号 S/N	型号理论重量 JMA Code & KG/M	型材图 Drawing	序号 S/N	型号理论重量 JMA Code & KG/M	型材图 Drawing	序号 S/N	型号理论重量 JMA Code & KG/M	型材图 Drawing
28	压线 JM5094D10 0.238kg/m		37			46		
29	压线 JM5094E10 0.202kg/m		38			47		
30	转角 JM509614 1.080kg/m		39			48		
31	转换框 JM509714 0.509kg/m		40			49		
32	转换框 JM5097A14 0.674kg/m		41			50		
33	角码 JMGR5505D 4.125kg/m		42			51		
34			43			52		
35			44			53		
36			45			54		

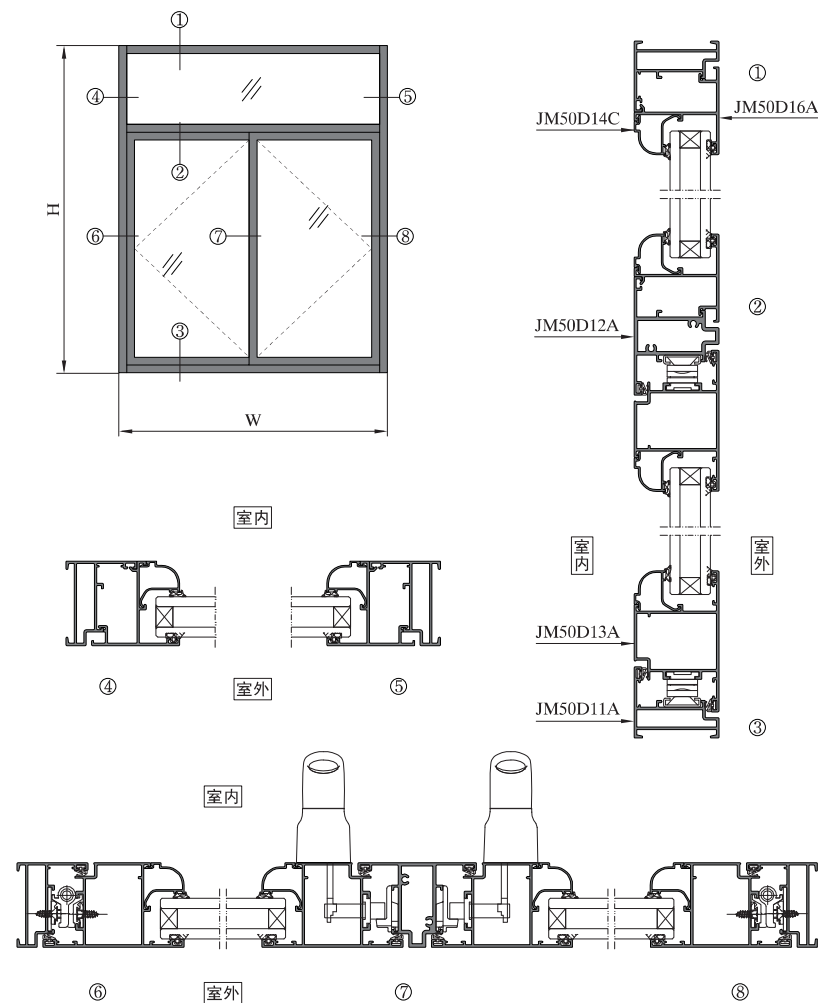

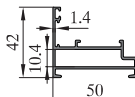
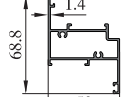
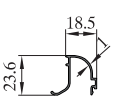
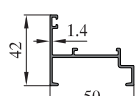
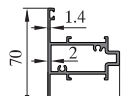
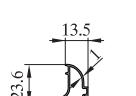
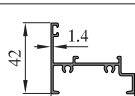
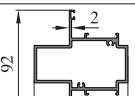
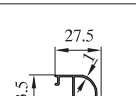
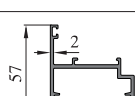
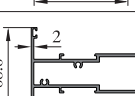
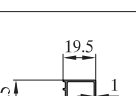
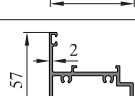
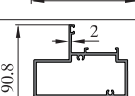
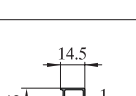
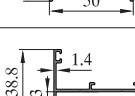
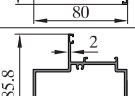
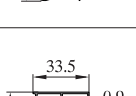
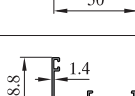
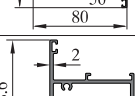
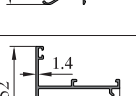
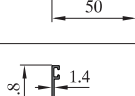
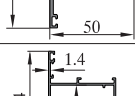
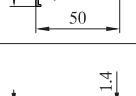
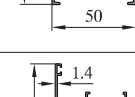
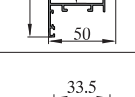
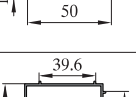
序号 S/N	型号理论重量 JMA Code & KG/M	型材图 Drawing	序号 S/N	型号理论重量 JMA Code & KG/M	型材图 Drawing	序号 S/N	型号理论重量 JMA Code & KG/M	型材图 Drawing
1	框料 JM553114 0.834kg/m	角码配JMGR6036 50 50.8 1.4 30	10	压线 JM5534D09 0.244kg/m	玻璃开口12mm 33.8 0.9 25.6	19	转角 JM5539C14 1.274kg/m	50 104° 1.4 50
2	中挺 JM553214 0.989kg/m	50 71.6 1.4 30	11	压线 JM5534E09 0.190kg/m	玻璃开口27mm 18.8 0.9 25.6	20	转角 JM5539D14 1.044kg/m	1.4 171 50 79.81
3	中挺 JM5532A14 1.429kg/m	90 71.6 1.4 30	12	压线 JM5534F09 0.184kg/m	玻璃开口27mm 18.8 0.9 25.6	21	转角 JM5539E14 1.247kg/m	112° 1.4 50 95.46
4	扇料 JM553314 1.109kg/m	角码配 JMGR6036 58 69.6 1.4	13	压线 JM553509 0.230kg/m	玻璃开口14mm 31.8 0.9 22	22	转角 JM5539F14 1.093kg/m	156° 1.4 50 90.71
5	扇料 JM553614 0.968kg/m	角码配 JMGR6047 50 71.6 1.4 33.8	14	压线 JM5535A09 0.170kg/m	玻璃开口27mm 18.8 0.9 21.8 19.68	23	转角 JM5539G14 1.257kg/m	133° 1.4 50 105.07
6	压线 JM553409 0.228kg/m	18.8 玻璃开口27mm 1 25.6 19.98	15	转换框 JM553714 0.731kg/m	48.1 1.4 50	24	角码 JMGR6047 2.502kg/m	60 3 27.2 60
7	压线 JM5534A09 0.269kg/m	玻璃开口14mm 31.8 1.1 25.6	16	转角 JM5539 0.846kg/m	1.4 50 50	25	角码 JMGR6036 2.278kg/m	60 60 17
8	压线 JM5534B09 0.229kg/m	18.8 玻璃开口27mm 0.9 25.6	17	转角 JM5539A14 1.665kg/m	1.4 80.8 105.8	26		
9	压线 JM5534C09 0.264kg/m	玻璃开口12mm 33.8 0.9 25.6	18	转角 JM5539B14 1.030kg/m	1.4 175 50 76.2	27		

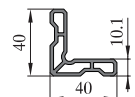
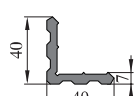

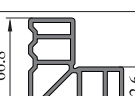
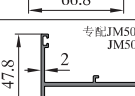
序号 S/N	型号理论重量 JMA Code & KG/M	型材图 Drawing	序号 S/N	型号理论重量 JMA Code & KG/M	型材图 Drawing	序号 S/N	型号理论重量 JMA Code & KG/M	型材图 Drawing
1	窗框 JM50D11A 0.739kg/m		10	中挺 JM50D12F 0.966kg/m		19	压线 JM50D14C 0.208kg/m	
2	窗框 JM50D11B 0.537kg/m		11	中挺 JM50D12A 1.213kg/m		20	压线 JM50D14D 0.204kg/m	
3	窗框 JM50D11C 0.612kg/m		12	中挺 JM50D12B 2.013kg/m		21	压线 JM50D14E 0.246kg/m	
4	窗框 JM50D11D 0.881kg/m		13	中挺 JM50D12C 1.662kg/m		22	压线 JM50D14J 0.219kg/m	
5	窗框 JM50D11DA 0.957kg/m		14	中挺 JM50D12D 1.955kg/m		23	压线 JM50D14K 0.217kg/m	
6	固定框 JM50D17A 0.703kg/m		15	中挺 JM50D12E 1.926kg/m		24	压线 JM50D14L 0.272kg/m	
7	固定框 JM50D17B 0.509kg/m		16	中挺 JM50D12G 1.245kg/m		25	转换框 JM50D16A 0.564kg/m	
8	固定框 JM50D17C 0.585kg/m		17	窗扇 JM50D13A 1.088kg/m		26	转角 H50C57A 0.436kg/m	
9	中挺 JM50D12H 0.890kg/m		18	压线 JM50D14A 0.248kg/m		27	转角 H50C57B 0.969kg/m	

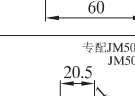
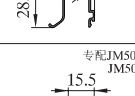
序号 S/N	型号理论重量 JMA Code & KG/M	型材图 Drawing	序号 S/N	型号理论重量 JMA Code & KG/M	型材图 Drawing	序号 S/N	型号理论重量 JMA Code & KG/M	型材图 Drawing
28	角码 JM50D16C 0.988kg/m		37			46		
29	角码 PC5026B 1.096kg/m		38			47		
30	角码 Y14524A 1.754kg/m		39			48		
31	角码 JM50D16D 3.488kg/m		40			49		
32	固定框 JM50D18A 0.827kg/m		41			50		
33	固定框 JM50D18B 1.144kg/m		42			51		
34	固定压线 JM50D19A 0.235kg/m		43			52		
35	固定压线 JM50D19C 0.234kg/m		44			53		
36			45			54		

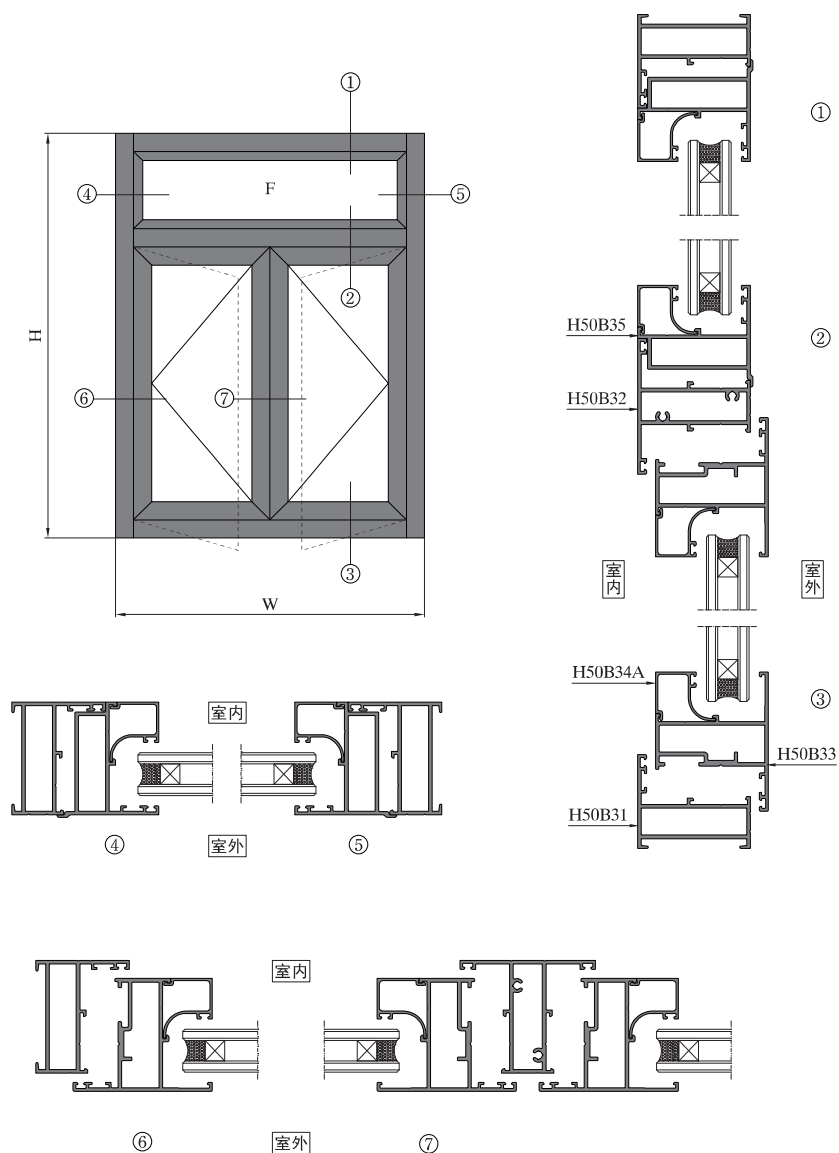

序号 S/N	型号理论重量 JMA Code & KG/M	型材图 Drawing	序号 S/N	型号理论重量 JMA Code & KG/M	型材图 Drawing	序号 S/N	型号理论重量 JMA Code & KG/M	型材图 Drawing
1	框料 H50B31 0.805kg/m		10	转换料 H50B35A 0.519kg/m		19		
2	框料 H50B31A 0.571kg/m		11	转角 H50B36 1.207kg/m		20		
3	框料 H50B31B 0.639kg/m		12	转角 H50B36A 1.207kg/m		21		
4	中挺 H50B32 0.957kg/m		13	压线 H50B34 0.217kg/m		22		
5	中挺 H50B32A 0.888kg/m		14	压线 H50B34A 0.217kg/m		23		
6	加强中挺 H50B32C 1.544kg/m		15	压线 H50B34B 0.283kg/m		24		
7	加强中挺 H50B32E 1.574kg/m		16	角码 PC6087 2.035kg/m		25		
8	扇料 H50B33 0.976kg/m		17			26		
9	转换料 H50B35 0.760kg/m		18			27		

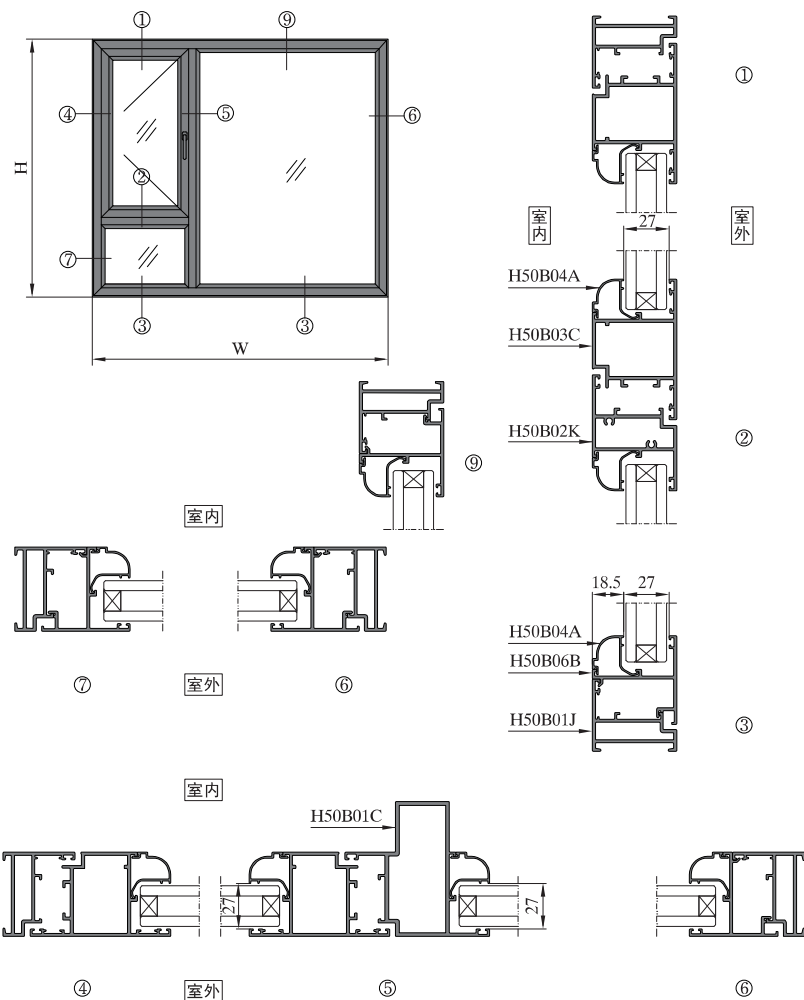

序号 S/N	型号理论重量 JMA Code & KG/M	型材图 Drawing	序号 S/N	型号理论重量 JMA Code & KG/M	型材图 Drawing	序号 S/N	型号理论重量 JMA Code & KG/M	型材图 Drawing
1	边框 H50B01J 0.914kg/m		10	压线 H50B04A 0.205kg/m		19	转角 H50C57A 0.436kg/m	
2	中挺 H50B02K 1.180kg/m		11	压线 H50B04D 0.244kg/m		20	转角 H50C57B 0.969kg/m	
3	中挺 H50B02B 1.172kg/m		12	压线 H50B04E 0.255kg/m		21	转换框 H50B06B 0.683kg/m	
4	中挺 H50B02C 1.170kg/m		13	压线 H50B04C 0.248kg/m		22		
5	中挺 H50B02D 1.521kg/m		14	压线 JM50D14J 0.219kg/m		23		
6	中挺 H50B02A 1.929kg/m		15	压线 JM50D14K 0.217kg/m		24		
7	中挺 H50B01C 1.849kg/m		16	压线 JM50D14L 0.272kg/m		25		
8	扇料 H50B03C 1.340kg/m		17	角码 JM50D16C 0.988kg/m		26		
9	压线 H50B04F 0.199kg/m		18	角码 JMGR7598 3.187kg/m		27		

图中所示型材截面、装配、编号、尺寸及重量仅供参考。如有疑问，请向本公司查询。
Information above just for your reference. Please contact us if you have any questions, Thank you!

图中所示型材截面、装配、编号、尺寸及重量仅供参考。如有疑问，请向本公司查询。
Information above just for your reference. Please contact us if you have any questions, Thank you!

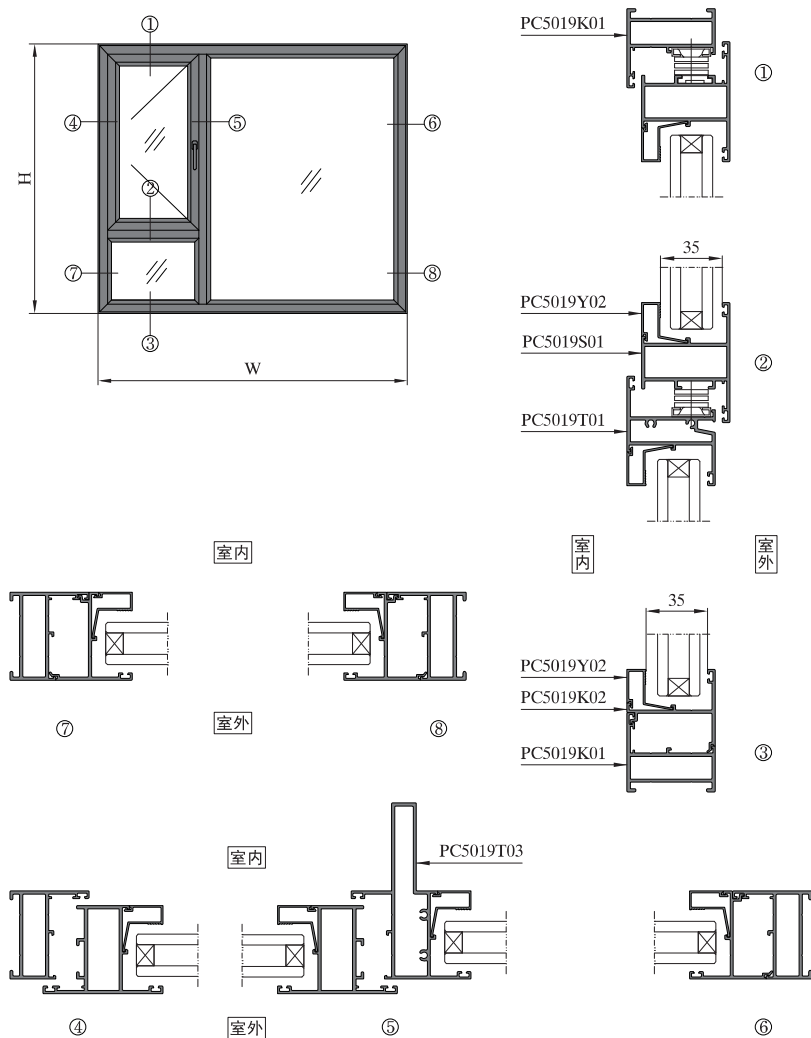

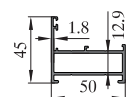
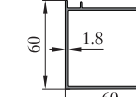
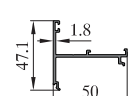
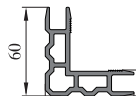
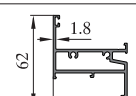
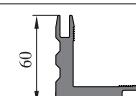
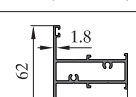
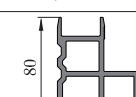
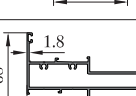
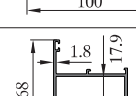
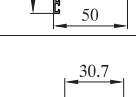
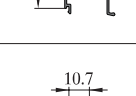
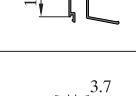
序号 S/N	型号理论重量 JMA Code & KG/M	型材图 Drawing	序号 S/N	型号理论重量 JMA Code & KG/M	型材图 Drawing	序号 S/N	型号理论重量 JMA Code & KG/M	型材图 Drawing
1	窗框 PC5019K01 0.929kg/m		10	转角 PC5019J01 1.209kg/m		19		
2	转换框 PC5019K02 0.573kg/m		11	角码 PC5007W01 2.118kg/m		20		
3	中挺 PC5019T01 1.086kg/m		12	角码 PC5007W02 2.845kg/m		21		
4	中挺 PC5019T02 1.068kg/m		13	角码 PC5007W03 4.129kg/m		22		
5	中挺 PC5019T03 1.658kg/m		14			23		
6	扇窗 PC5019S01 1.118kg/m		15			24		
7	压线 PC5019Y01 0.261kg/m		16			25		
8	压线 PC5019Y02 0.212kg/m		17			26		
9	压线 PC5019Y04 0.206kg/m		18			27		

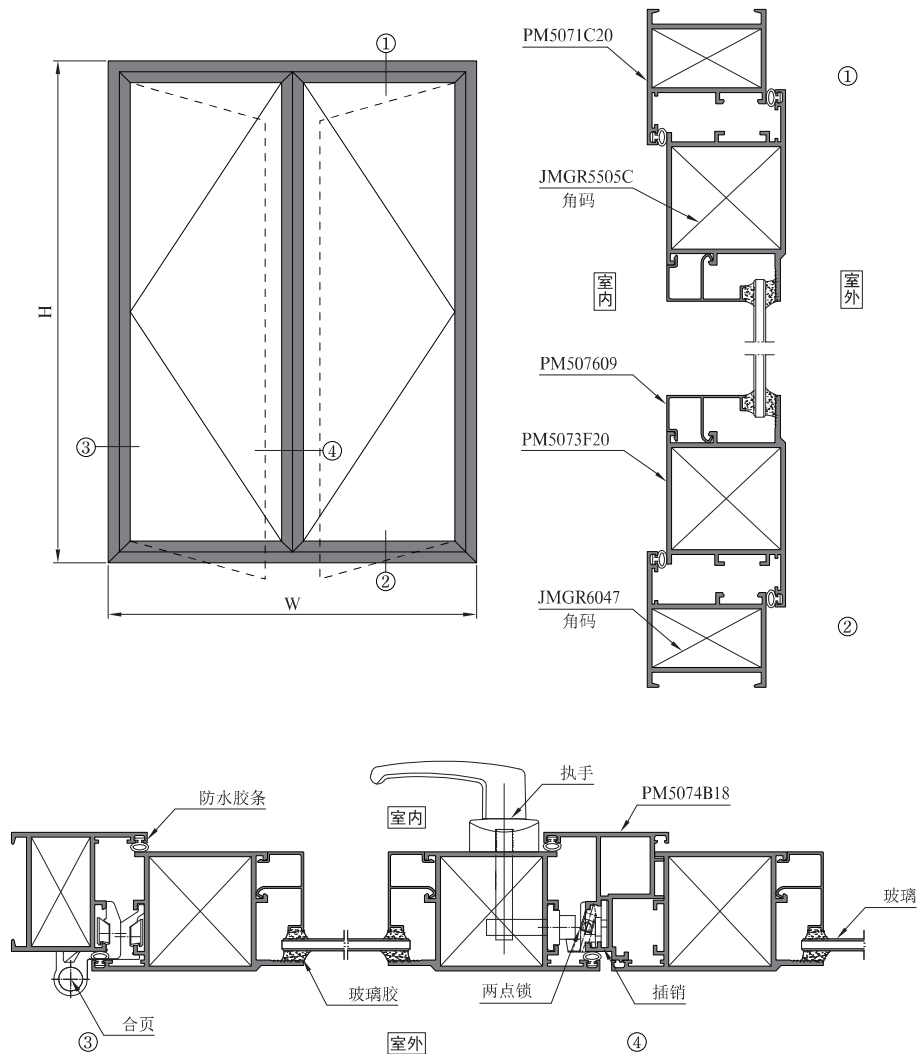

序号 S/N	型号理论重量 JMA Code & KG/M	型材图 Drawing	序号 S/N	型号理论重量 JMA Code & KG/M	型材图 Drawing	序号 S/N	型号理论重量 JMA Code & KG/M	型材图 Drawing
1	框料 PM5071I15 0.985kg/m	角码配JMGR6047 57, 1.5, 39.8, 50	10	扇料 PM5073B15 1.197kg/m	角码配JMGR5505C 88, 1.5, 50	19	压线 PM5076D10 0.166kg/m	玻璃开口32.3mm 14, 19.8
2	框料 PM5071A18 1.115kg/m	角码配JMGR6047 57, 1.8, 39.8, 50	11	扇料 PM5073C15 1.163kg/m	角码配JMGR5505C 70.8, 1.5, 48.3	20	角码 JMGR5505C 7.855kg/m	108, 7, 42.7, 108
3	框料 PM5071B15 0.724kg/m	角码配JMGR6047 47, 1.5, 29.8, 50	12	扇料 PM5073F20 1.524kg/m	角码配JMGR5505C 89, 2, 50	21	角码 JMGR6047 2.502kg/m	60, 3, 24.5, 60
4	框料 PM5071C20 1.188kg/m	角码配JMGR6047 57, 2, 50	13	假中挺 PM5074I5 0.892kg/m	角码配JMGR6047 52.5, 1.5, 55.5	22	角码 JMGR5236 7.735kg/m	8, 90, 37.7, 90
5	中挺 PM5072I5 1.107kg/m	角码配JMGR6047 80, 1.5, 45.6, 50	14	假中挺 PM5074B18 1.011kg/m	角码配JMGR6047 52.5, 1.8, 53.7	23		
6	中挺 PM5072A15 1.787kg/m	角码配JMGR6047 80, 1.5, 45.6, 100	15	扇中挺 PM5077I5 1.557kg/m	角码配JMGR6047 89.6, 1.5, 48.3, 120	24		
7	中挺 PM5072B15 1.962kg/m	角码配JMGR6047 80, 1.5, 45.6, 120	16	压线 PM507609 0.238kg/m	玻璃开口13mm 33.3, 0.9, 20	25		
8	扇料 PM5073I5 1.153kg/m	角码配JMGR5236 83, 1.5, 50	17	压线 PM5076A09 0.208kg/m	玻璃开口23mm 23.3, 20	26		
9	扇料 PM5073A18 1.333kg/m	角码配JMGR5236 83.6, 1.8, 50	18	压线 PM5076C10 0.158kg/m	玻璃开口32.3mm 14, 19.8	27		

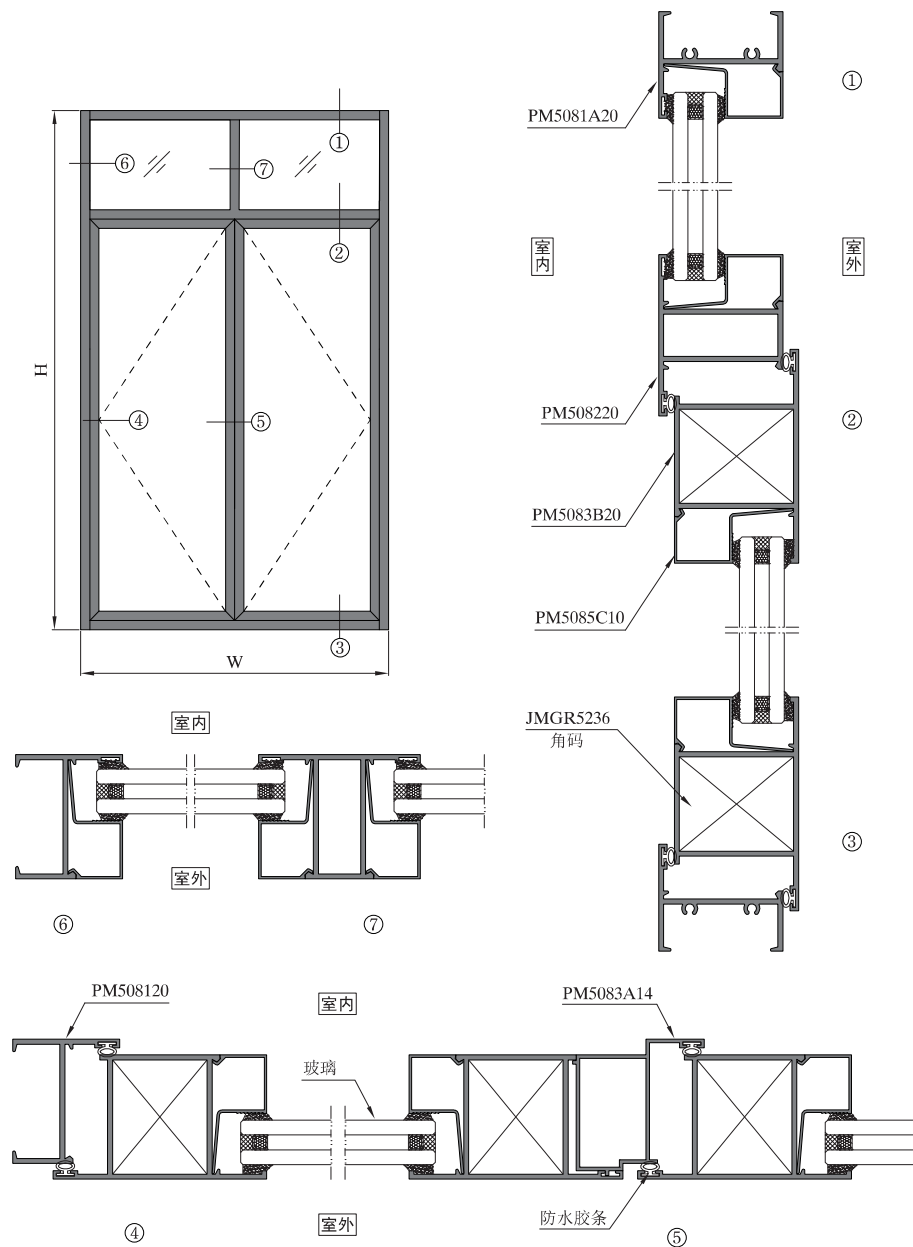

序号 S/N	型号理论重量 JMA Code & KG/M	型材图 Drawing	序号 S/N	型号理论重量 JMA Code & KG/M	型材图 Drawing	序号 S/N	型号理论重量 JMA Code & KG/M	型材图 Drawing
1	框料 PM508114 0.540kg/m		10	假中挺 PM5083A14 0.765kg/m		19		
2	框料 PM508120 0.699kg/m		11	框扇压线 PM508510 0.234kg/m		20		
3	框料 PM5081A14 0.615kg/m		12	框扇压线 PM5085B10 0.273kg/m		21		
4	框料 PM5081A20 0.773kg/m		13	框扇压线 PM5085A10 0.239kg/m		22		
5	中挺 PM508214 0.851kg/m		14	框扇压线 PM5085C10 0.270kg/m		23		
6	中挺 PM508220 1.107kg/m		15	角码 JM5508 3.533kg/m		24		
7	扇料 PM508314 0.810kg/m		16	角码 JMGR5236 7.735kg/m		25		
8	扇料 PM508320 1.106kg/m		17			26		
9	扇料 PM5083B20 1.348kg/m		18			27		

图中所示型材截面、装配、编号、尺寸及重量仅供参考。如有疑问，请向本公司查询。
Information above just for your reference. Please contact us if you have any questions, Thank you!

图中所示型材截面、装配、编号、尺寸及重量仅供参考。如有疑问，请向本公司查询。
Information above just for your reference. Please contact us if you have any questions, Thank you!

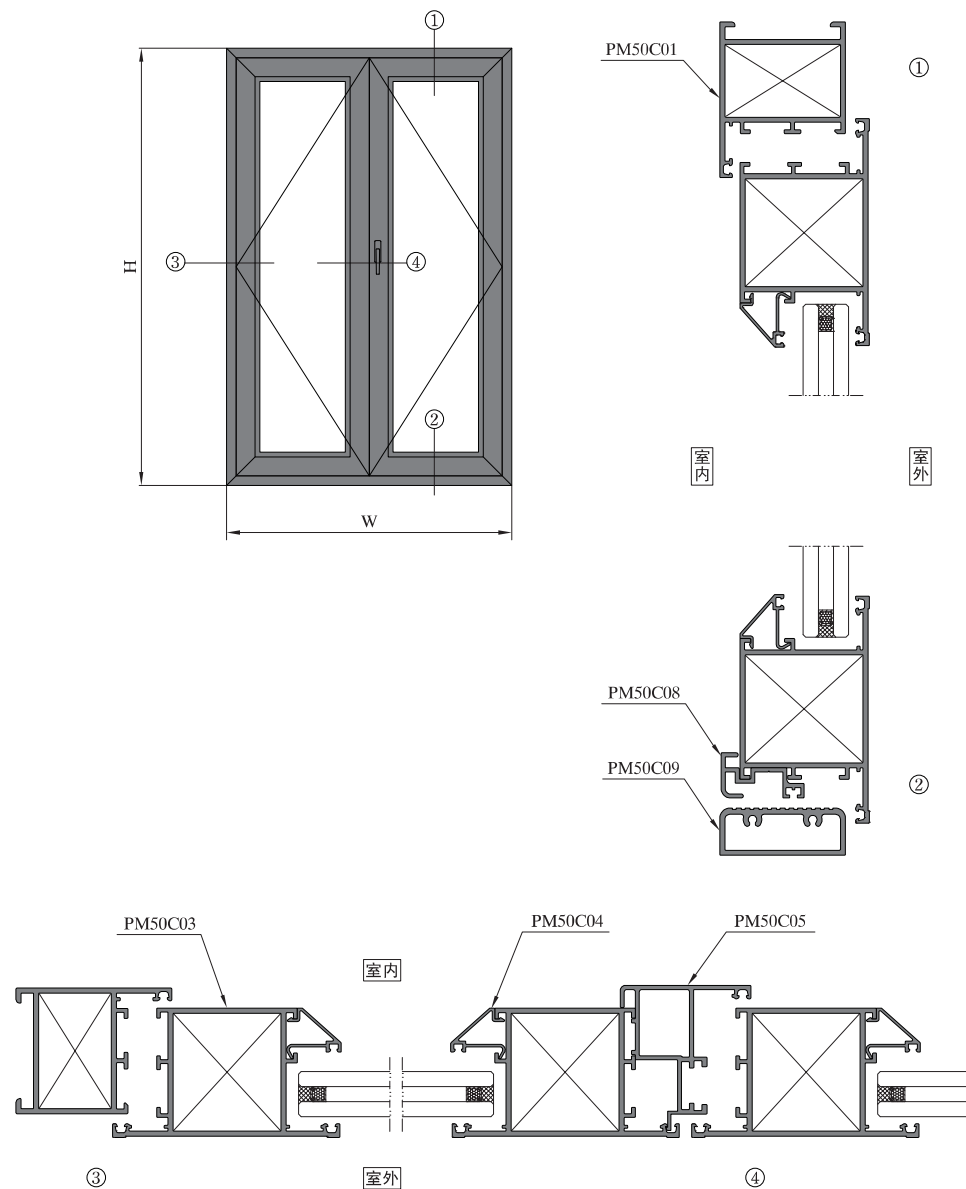
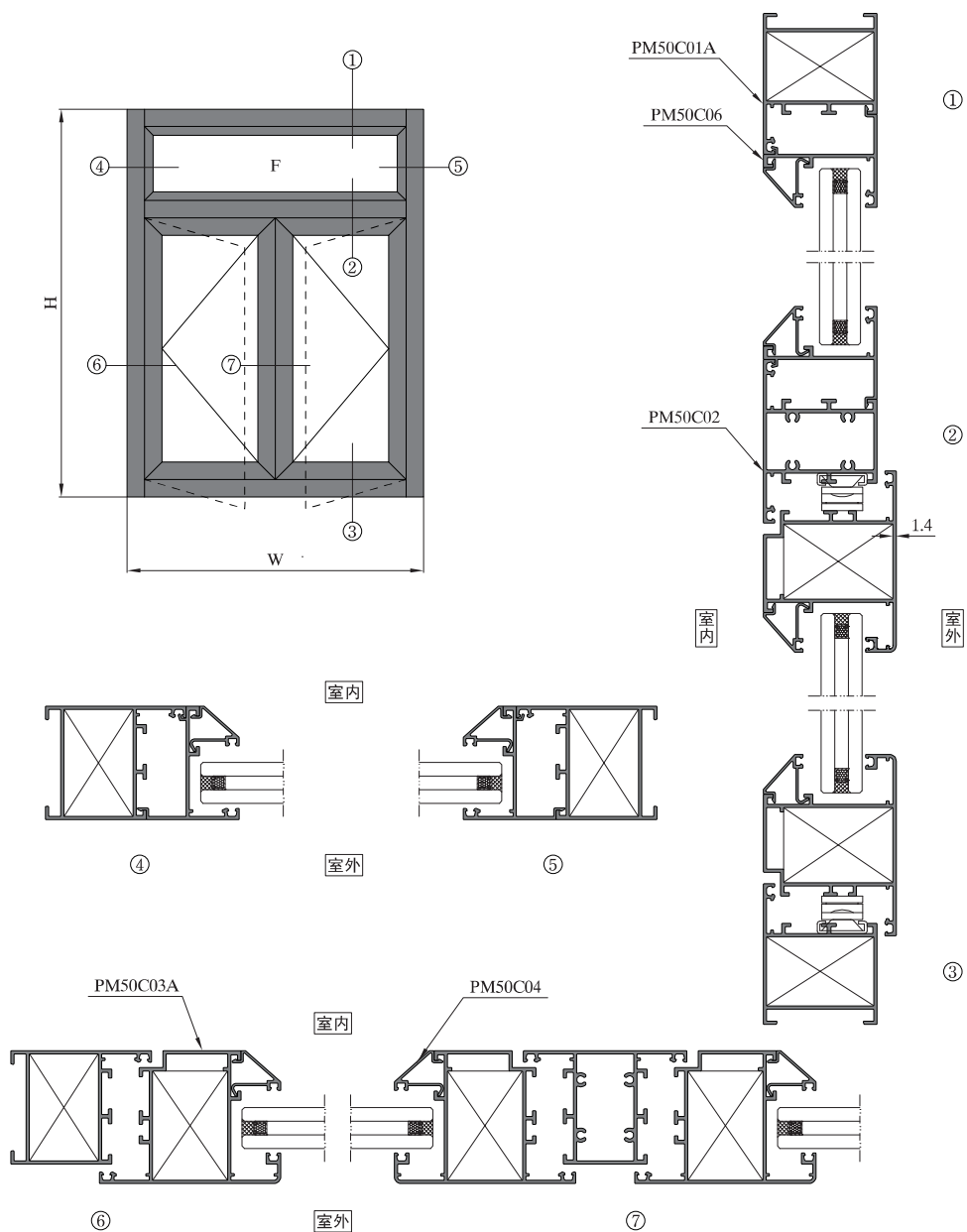

序号 S/N	型号理论重量 JMA Code & KG/M	型材图 Drawing	序号 S/N	型号理论重量 JMA Code & KG/M	型材图 Drawing	序号 S/N	型号理论重量 JMA Code & KG/M	型材图 Drawing
1	框料 PM50C01 1.314kg/m		10	扇料 PM50C03A 1.234kg/m		19	角码 JM5508 3.533kg/m	
2	框料 PM50C01A 0.989kg/m		11	压线 PM50C04 0.190kg/m		20	角码 JMGR5505C 7.855kg/m	
3	框料 PM50C01B 0.843kg/m		12	压线 PM50C04A 0.211kg/m		21	角码 JMGR1710 4.652kg/m	
4	框料 PM50C01C 0.915kg/m		13	假中挺 PM50C05 0.955kg/m		22		
5	中挺 PM50C02 1.241kg/m		14	转换料 PM50C06 0.509kg/m		23		
6	加强中挺 PM50C02A 1.591kg/m		15	拼条 PM50C07 0.525kg/m		24		
7	中挺 PM50C02B 1.094kg/m		16	门底封边 PM50C08 0.397kg/m		25		
8	加强中挺 PM50C02D 1.443kg/m		17	门槛 PM50C09 0.909kg/m		26		
9	扇料 PM50C03 1.588kg/m		18	角码 JMGR5217 4.264kg/m		27		

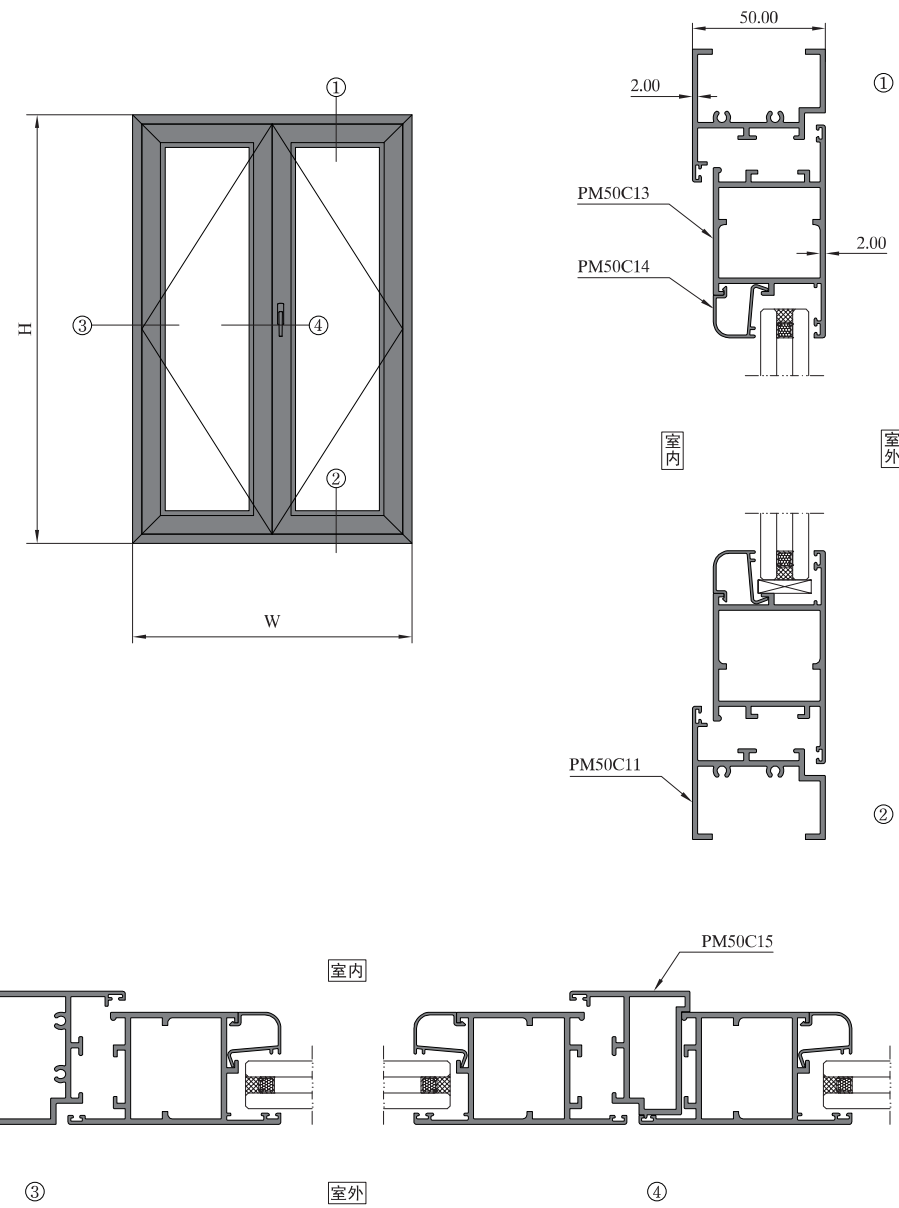

图中所示型材截面、装配、编号、尺寸及重量仅供参考。如有疑问，请向本公司查询。
Information above just for your reference. Please contact us if you have any questions, Thank you!

图中所示型材截面、装配、编号、尺寸及重量仅供参考。如有疑问，请向本公司查询。
Information above just for your reference. Please contact us if you have any questions, Thank you!

序号 S/N	型号理论重量 JMA Code & KG/M	型材图 Drawing	序号 S/N	型号理论重量 JMA Code & KG/M	型材图 Drawing	序号 S/N	型号理论重量 JMA Code & KG/M	型材图 Drawing
1	框料 PM50C11 0.971kg/m		10			19		
2	框料 PM50C11A 0.657kg/m		11			20		
3	外开扇 PM50C13 1.368kg/m	角码配GRB506 	12			21		
4	扇压线 PM50C14 0.179kg/m		13			22		
5	假中挺 PM50C15 0.997kg/m		14			23		
6	角码 GRB506 2.991kg/m		15			24		
7			16			25		
8			17			26		
9			18			27		

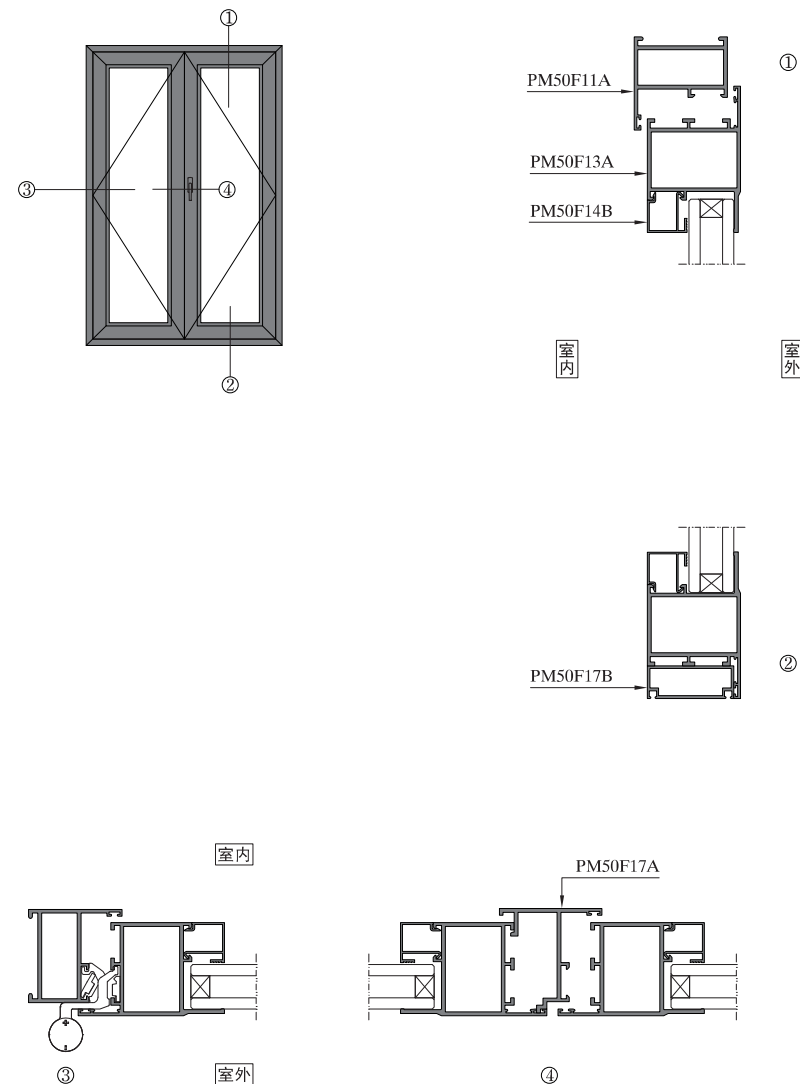

序号 S/N	型号理论重量 JMA Code & KG/M	型材图 Drawing	序号 S/N	型号理论重量 JMA Code & KG/M	型材图 Drawing	序号 S/N	型号理论重量 JMA Code & KG/M	型材图 Drawing
1	框料 PM50F11A 1.088kg/m		10	角码 H50B28A 3.175kg/m		19		
2	中挺 PM50F12A 1.36kg/m		11	转角 H50C57B 0.969kg/m		20		
3	扇料 PM50F13A 1.377kg/m		12			21		
4	压线 PM50F14A 0.276kg/m		13			22		
5	压线 PM50F14B 0.227kg/m		14			23		
6	假中挺 PM50F17A 0.859kg/m		15			24		
7	辅件 PM50F17B 0.527kg/m		16			25		
8	转角 H50C57A 0.436kg/m		17			26		
9	角码 JMGR100007B 3.263kg/m		18			27		

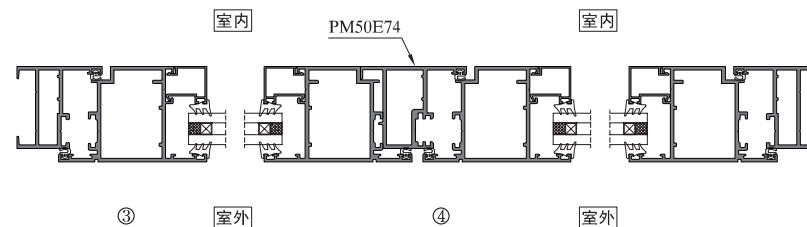
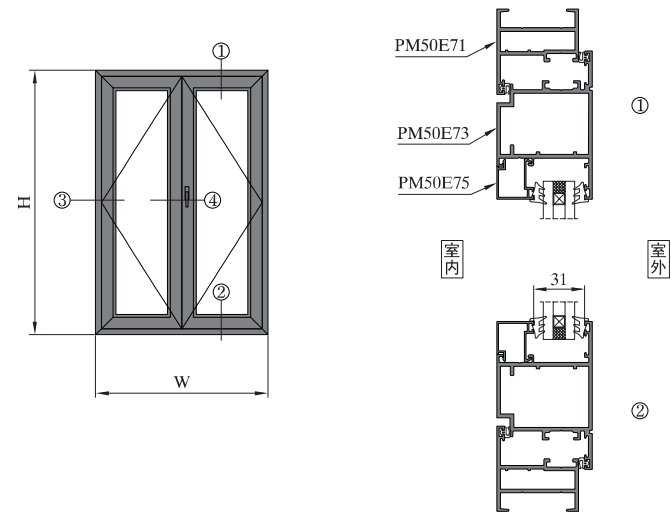

序号 S/N	型号理论重量 JMA Code & KG/M	型材图 Drawing	序号 S/N	型号理论重量 JMA Code & KG/M	型材图 Drawing	序号 S/N	型号理论重量 JMA Code & KG/M	型材图 Drawing
1	框料 PM50E71 T=2.20 1.230kg/m		10			19		
2	扇料 PM50E73 T=2.20 1.835kg/m		11			20		
3	假中挺 PM50E74 T=2.20 1.376kg/m		12			21		
4	压线 PM50E75 T=1.10 0.275kg/m		13			22		
5	压座 PM50E76 T=2.20 0.561kg/m		14			23		
6	压座压线 H50B75 T=1.10 0.226kg/m		15			24		
7	框角码 F-50625 T=2.50 1.786kg/m		16			25		
8	扇角码 GR65D59B T=3.70 4.249kg/m		17			26		
9			18			27		

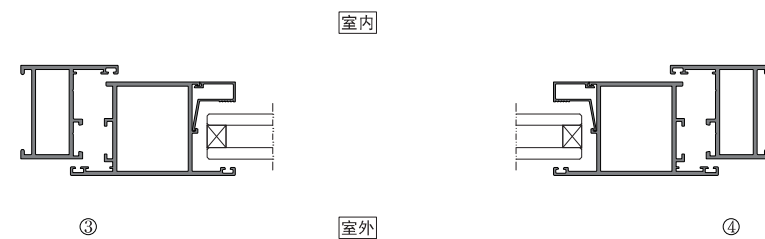
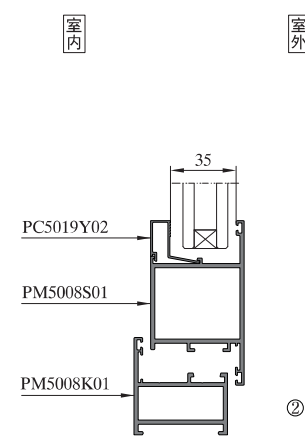
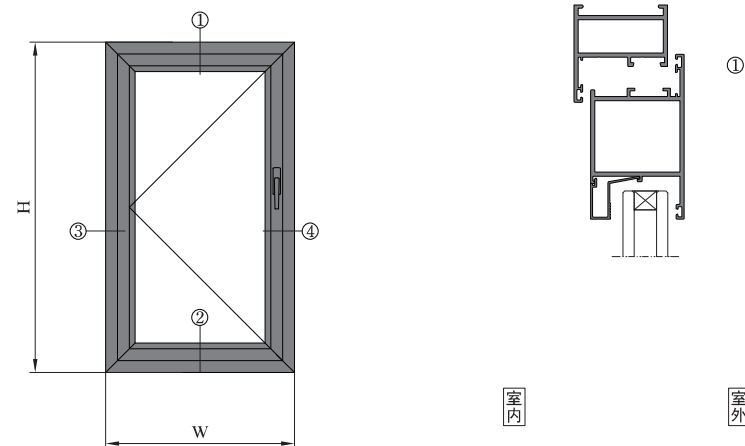

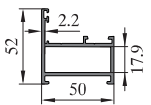
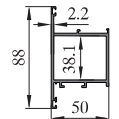
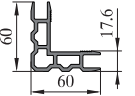
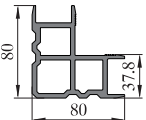
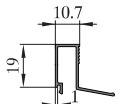
序号 S/N	型号理论重量 JMA Code & KG/M	型材图 Drawing	序号 S/N	型号理论重量 JMA Code & KG/M	型材图 Drawing	序号 S/N	型号理论重量 JMA Code & KG/M	型材图 Drawing
1	门框 PM5008K01 1.218kg/m		10			19		
2	门扇 PM5008S01 1.574kg/m		11			20		
3	角码 PC5007W01 2.118kg/m		12			21		
4	角码 PC5007W03 4.129kg/m		13			22		
5	压线 PC5019Y02 0.212kg/m		14			23		
6			15			24		
7			16			25		
8			17			26		
9			18			27		

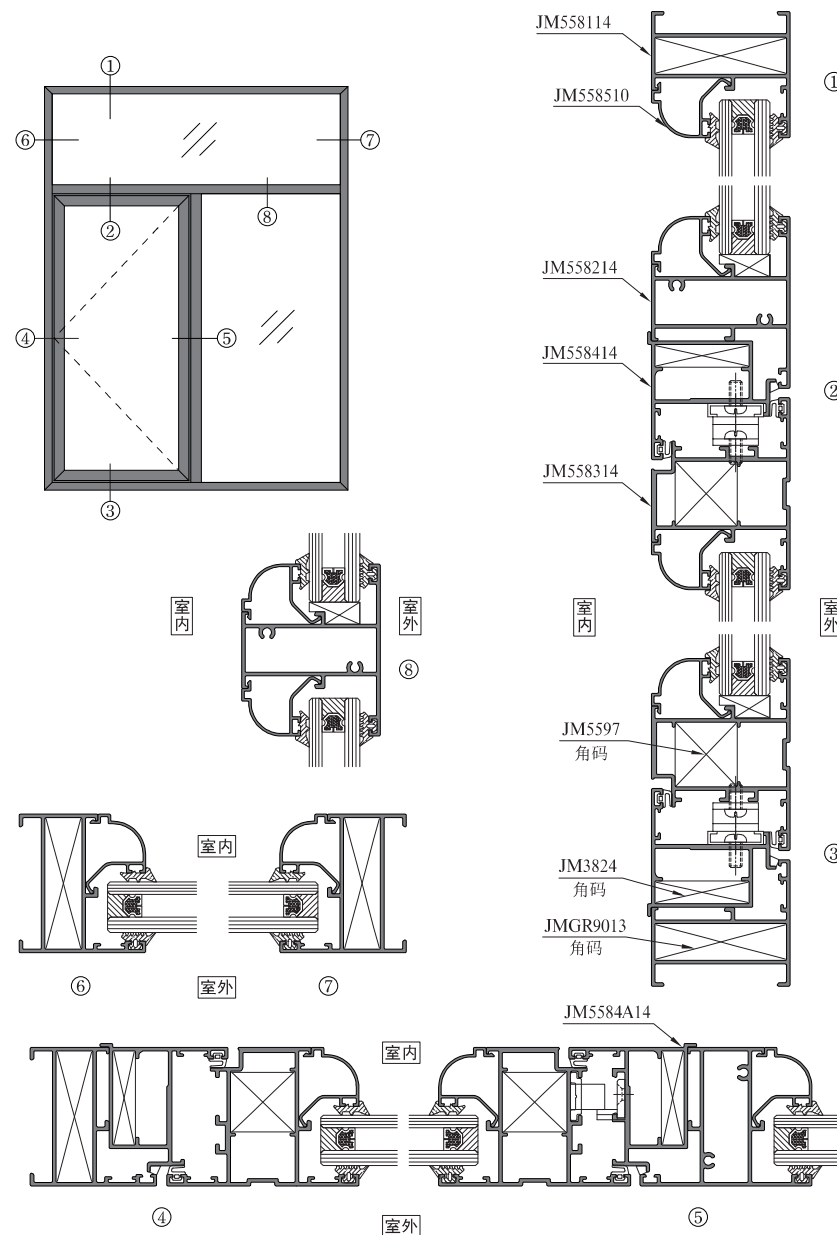

序号 S/N	型号理论重量 JMA Code & KG/M	型材图 Drawing	序号 S/N	型号理论重量 JMA Code & KG/M	型材图 Drawing	序号 S/N	型号理论重量 JMA Code & KG/M	型材图 Drawing
1	框料 JM558114 0.913kg/m		10	压线 JM5585C10 0.294kg/m		19		
2	中挺 JM558214 1.029kg/m		11	压线 JM5585E10 0.239kg/m		20		
3	中挺 JM5582A14 0.954kg/m		12	压线 JM5585F10 0.227kg/m		21		
4	扇料 JM558314 1.179kg/m		13	转角 JM5589 1.351kg/m		22		
5	转换料 JM558414 0.823kg/m		14	角码配JM3824 JM558625 1.213kg/m		23		
6	转换料 JM5584A14 0.886kg/m		15	角码 JM5597 2.527kg/m		24		
7	压线 JM558510 0.227kg/m		16	角码 JMGR9013 2.051kg/m		25		
8	压线 JM5585A10 0.242kg/m		17	角码 JM3824 1.331kg/m		26		
9	压线 JM5585B10 0.279kg/m		18			27		

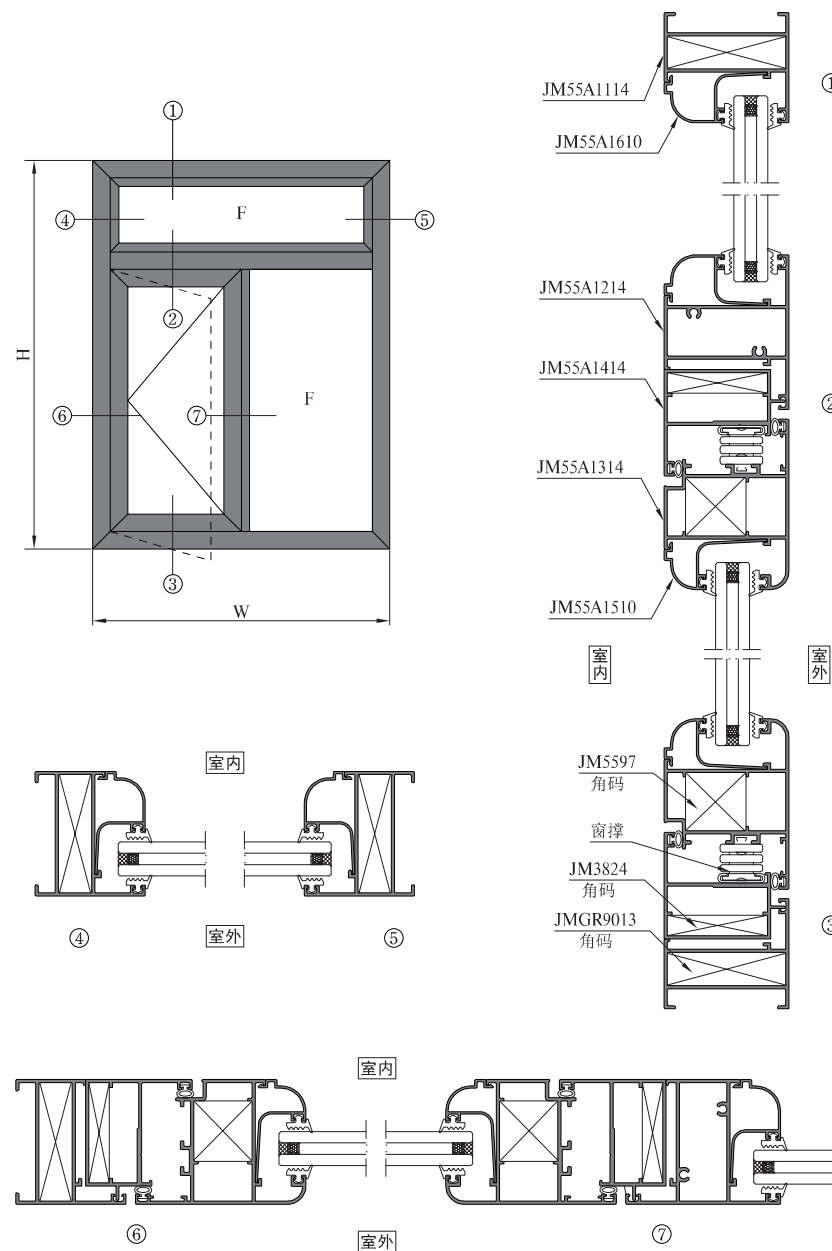

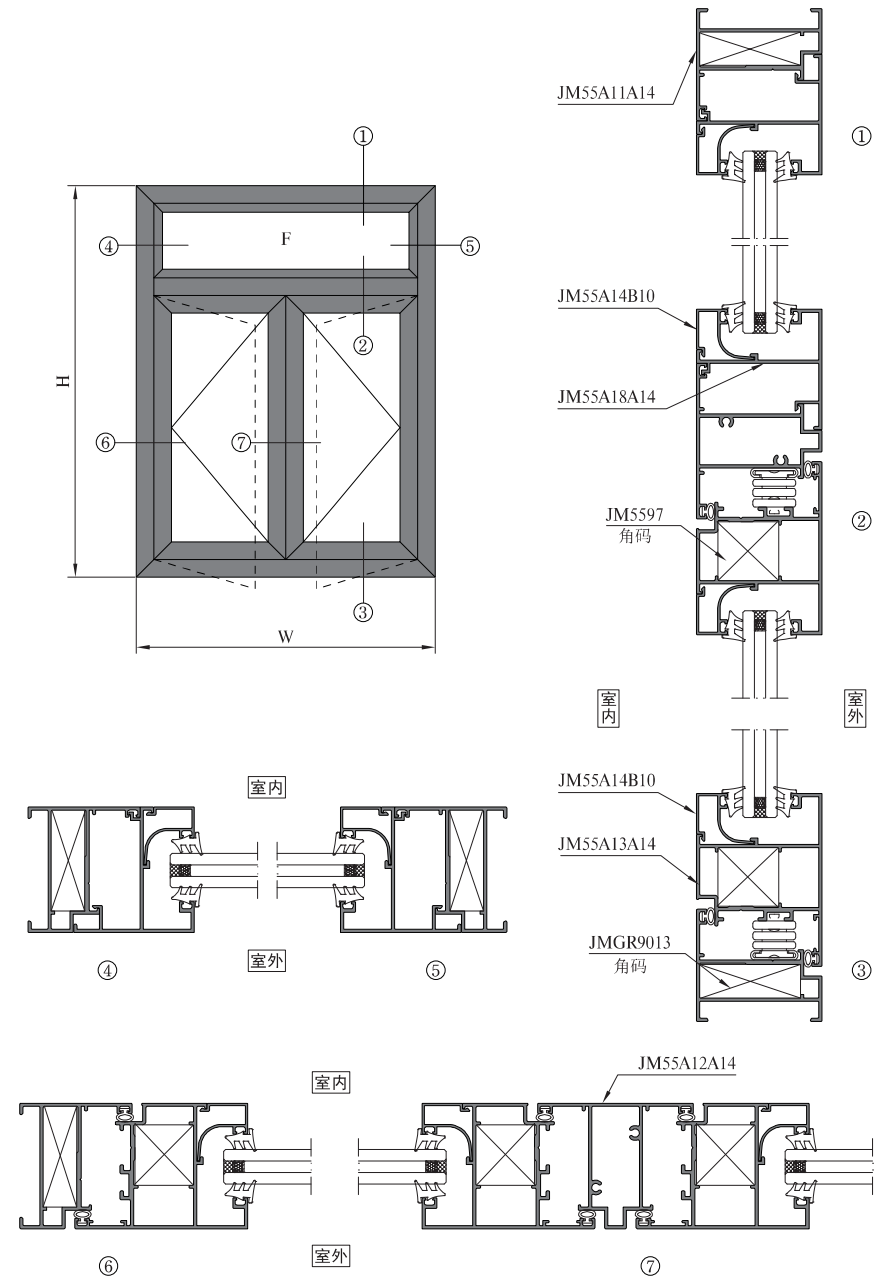
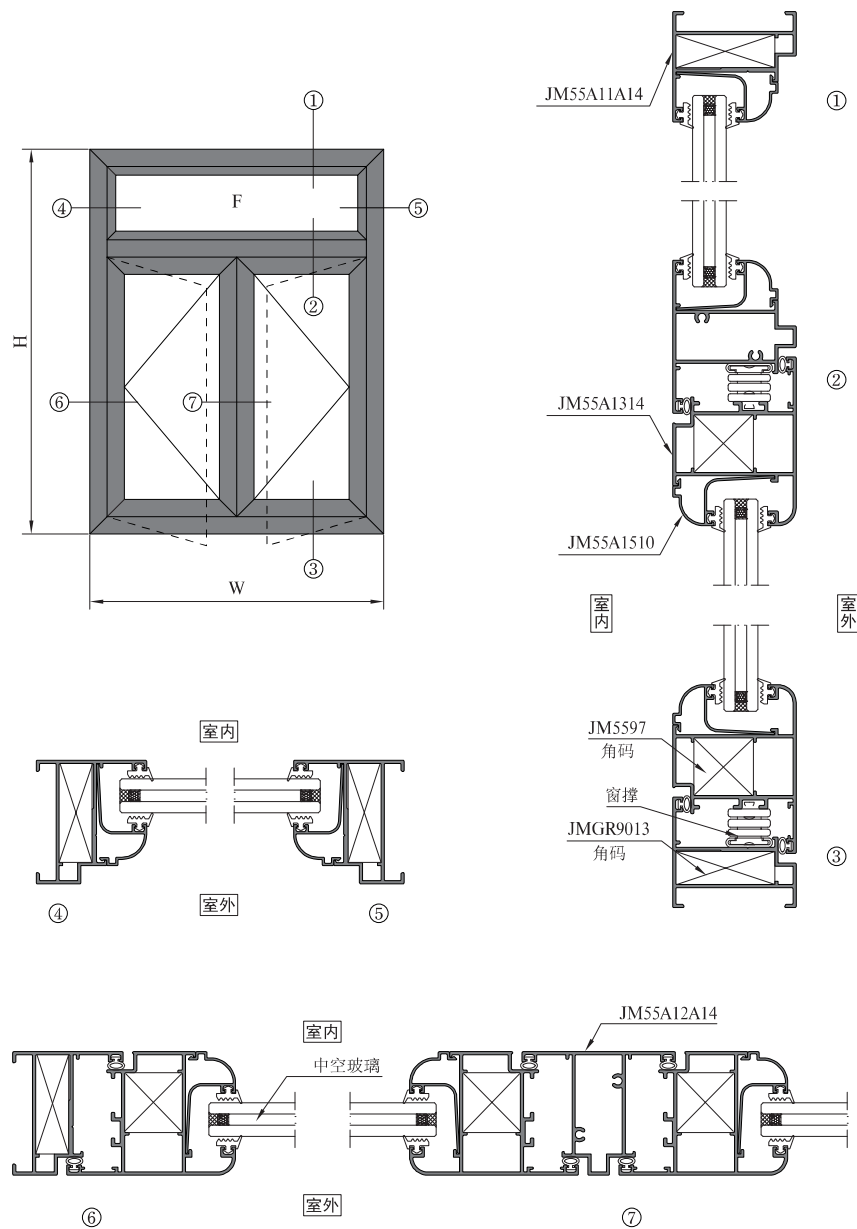

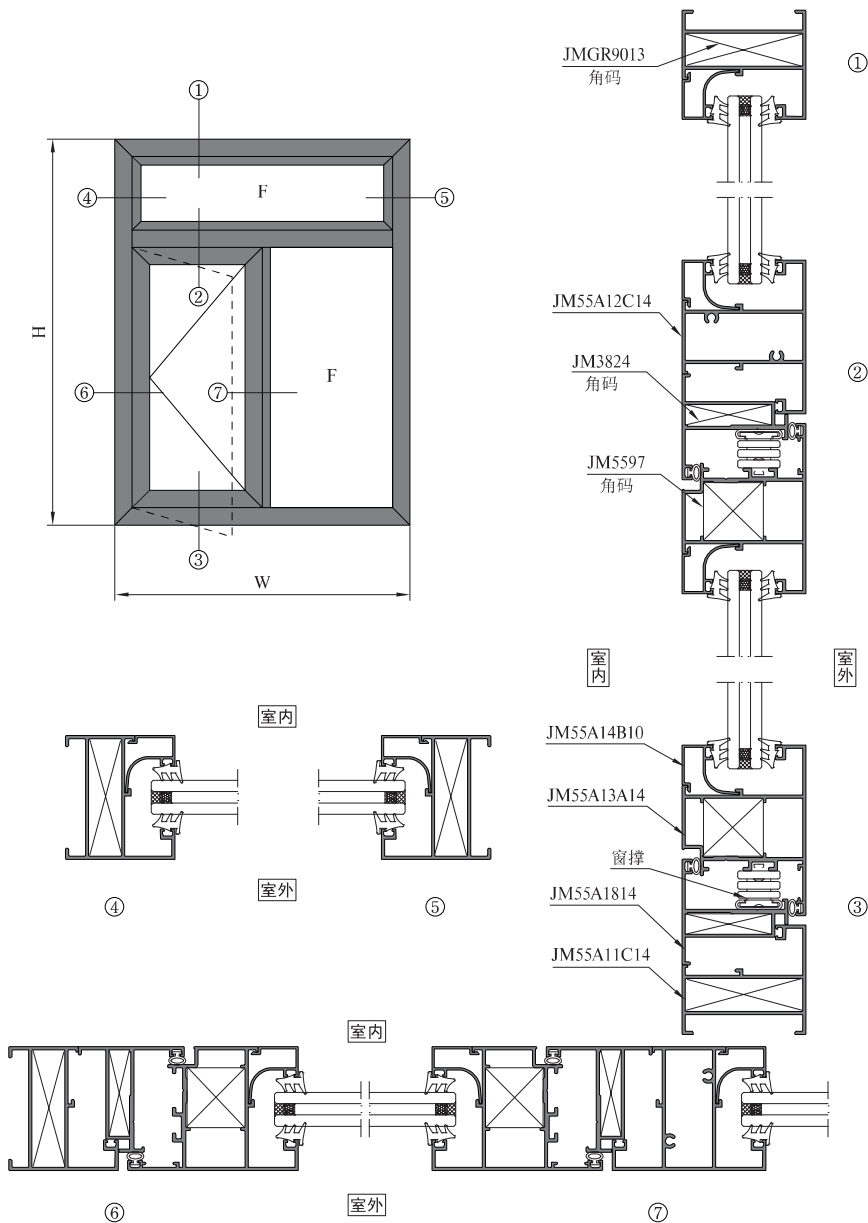

序号 S/N	型号理论重量 JMA Code & KG/M	型材图 Drawing	序号 S/N	型号理论重量 JMA Code & KG/M	型材图 Drawing	序号 S/N	型号理论重量 JMA Code & KG/M	型材图 Drawing
1	框料 JM55A1114 0.823kg/m	角码配JMGR9013 48.4 1.4 54.8 30.7	10	中挺 JM55A12A14 0.980kg/m	68 1.4 54.8 32.6	19	扇料 JM55A13A14 1.169kg/m	13.5 75.5 1.4 54.8 25.6
2	框料 JM55A11A14 0.864kg/m	角码配JMGR9013 49 1.4 54.8 31.3	11	中挺 JM55A12B14 1.589kg/m	90 74 1.4	20	扇料 JM55A13B14 1.121kg/m	54.8 75.5 1.4 25.6
3	框料 JM55A11C14 0.882kg/m	角码配JMGR9013 48.4 1.4 54.8 30.7	12	中挺 JM55A12C14 1.122kg/m	68 1.4 54.8 32.6	21	扇料 JM55A13C 1.254kg/m	46.8 29.6 1.4 90 74
4	框料 JM55A11E14 0.569kg/m	45 1.4 54.8	13	中挺 JM55A12E20 1.903kg/m	100 68 2 23.6	22	扇料 JM55A12G14 1.034kg/m	46.8 68 1.4
5	框料 JM55A11H 0.583kg/m	45 1.4 54.8	14	中挺 JM55A12H14 0.903kg/m	68 1.4 54.8	23	压线 JM55A14B10 0.212kg/m	13.5 1 22 25.2
6	框料 JM55A11D14 1.112kg/m	77.2 1.4 57.7	15	中挺 JM55A12J 0.980kg/m	54.8 74 1.4 38.6	24	压线 JM55A14C10 0.228kg/m	26.3 1 22 25.2
7	框料 JM55A11F14 1.273kg/m	84 1.4 84	16	中挺 JM55A12K 0.747kg/m	46.8 57 1.4 21.6	25	压线 JM55A14D10 0.238kg/m	26.2 1 22
8	框料 JM55A11G14 1.159kg/m	77 1.4 77	17	中挺 JM55A12L 1.268kg/m	90 74 1.4 29.6	26	压线 JM55A14F10 0.264kg/m	38.2 1 22 25.2
9	中挺 JM55A1214 1.003kg/m	68 1.4 54.8 32.6	18	扇料 JM55A1314 1.128kg/m	角码配JM5597 74.9 1.4 54.8	27	压线 JM55A14G 0.217kg/m	17.2 1 22 25.2

序号 S/N	型号理论重量 JMA Code & KG/M	型材图 Drawing	序号 S/N	型号理论重量 JMA Code & KG/M	型材图 Drawing	序号 S/N	型号理论重量 JMA Code & KG/M	型材图 Drawing
28	压线 JM55A14H 0.252kg/m		37	转换框 JM55A1814 0.694kg/m		46		
29	压线 JM55A14J 0.275kg/m		38	转换框 JM55A18A14 0.636kg/m		47		
30	转换框 JM55A1414 0.778kg/m		39	转换框 JM55A18B14 0.572kg/m		48		
31	压线 JM55A1510 0.260kg/m		40	转换框 JM55A18C 0.581kg/m		49		
32	压线 JM55A15B 0.237kg/m		41	转角 JM55A1914 0.999kg/m		50		
33	压线 JM55A15C 0.341kg/m		42	拼管 JM55A19A15 0.675kg/m		51		
34	压线 JM55A15D 0.343kg/m		43	角码 JMGR9013 2.051kg/m		52		
35	压线 JM55A1610 0.261kg/m		44	角码 JM3824 1.331kg/m		53		
36	压线 JM55A16A10 0.275kg/m		45	角码 JM5597 2.527kg/m		54		

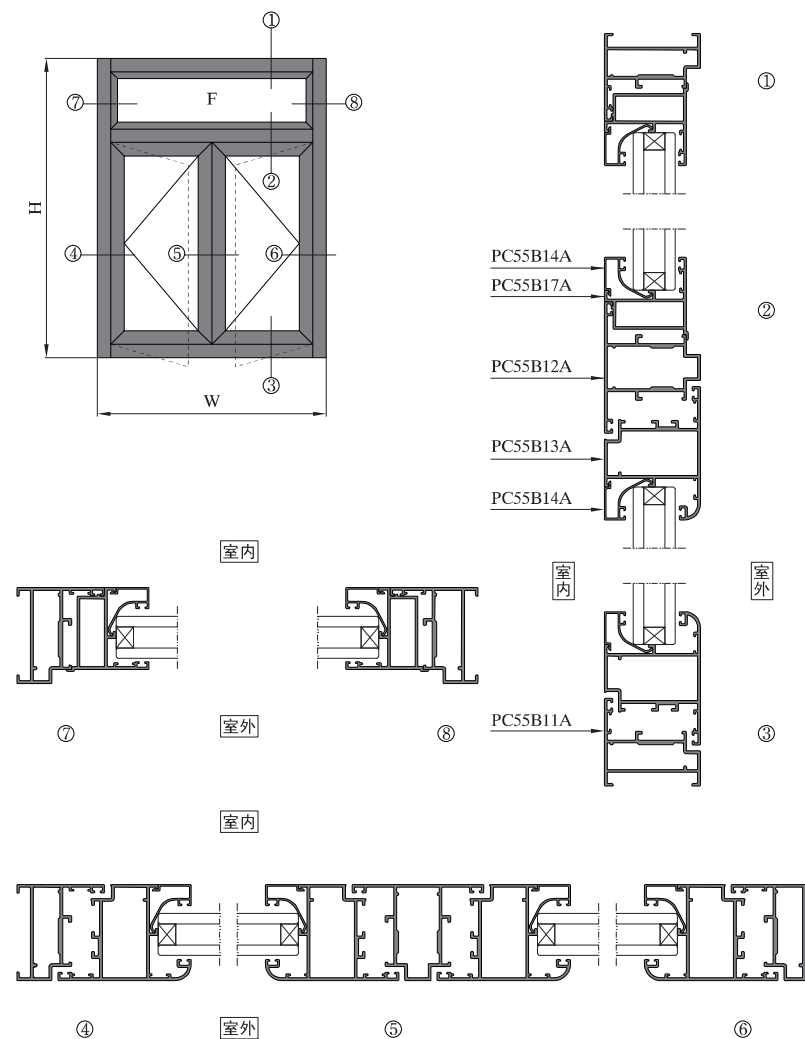

序号 S/N	型号理论重量 JMA Code & KG/M	型材图 Drawing	序号 S/N	型号理论重量 JMA Code & KG/M	型材图 Drawing	序号 S/N	型号理论重量 JMA Code & KG/M	型材图 Drawing
1	窗框 PC55B11A 1.039kg/m		10	中挺 PC55B12B 1.815kg/m		19	角码 JMGR55B47 1.988kg/m	
2	窗框 PC55B11C 0.702kg/m		11	中挺 PC55B12G 1.874kg/m		20	角码 JMGR55B47B 2.146kg/m	
3	窗框 PC55B11B 0.949kg/m		12	中挺 PC55B12C 1.992kg/m		21	转角 PC55B18C 1.186kg/m	
4	窗框 PC55B11E 1.679kg/m		13	窗扇 PC55B13A 1.281kg/m		22	压线 PC55B19C 0.215kg/m	
5	中挺 PC55B12A 1.214kg/m		14	压线 PC55B14A 0.226kg/m		23	压座 PC55B19D 0.502kg/m	
6	中挺 PC55B12H 1.650kg/m		15	压线 PC55B14B 0.282kg/m		24		
7	中挺 PC55B12E 1.571kg/m		16	压线 PC55B14D 0.203kg/m		25		
8	中挺 PC55B12F 1.130kg/m		17	转换框 PC55B17A 0.766kg/m		26		
9	中挺 PC55B12K 1.939kg/m		18	连接件 PC55B18A 1.198kg/m		27		

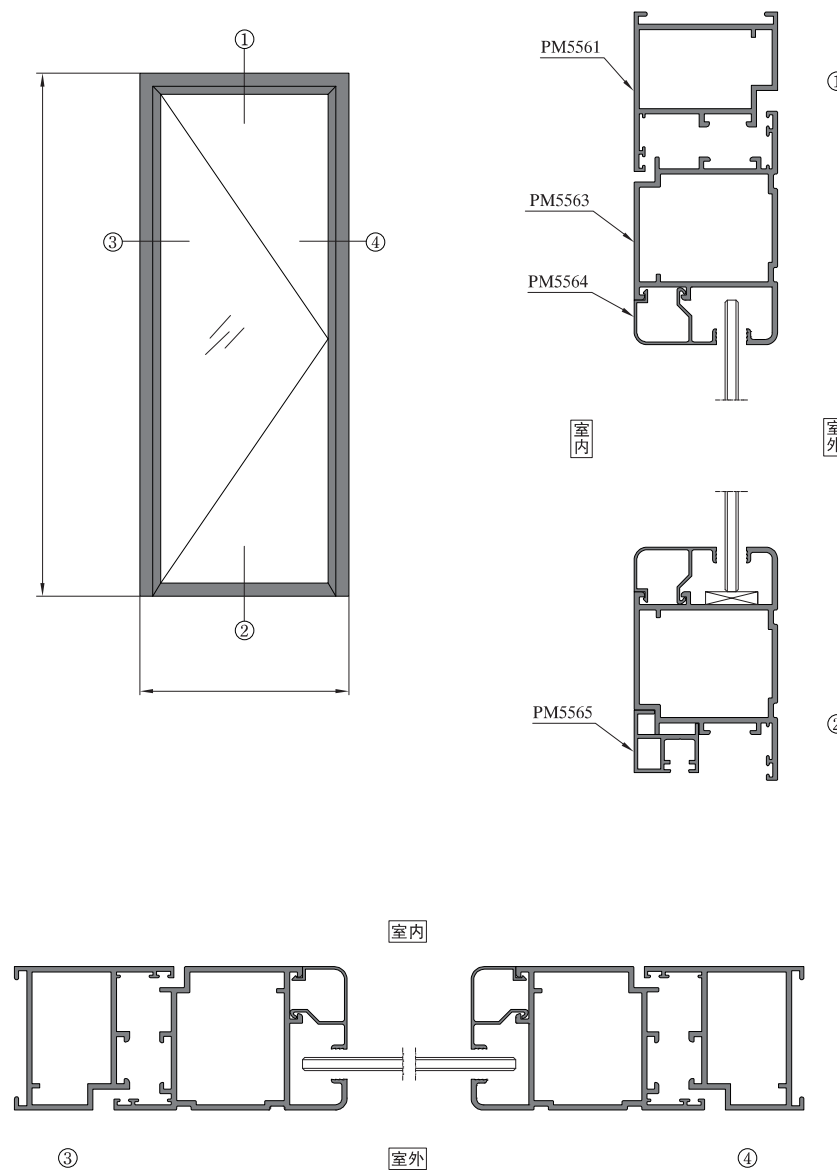

序号 S/N	型号理论重量 JMA Code & KG/M	型材图 Drawing	序号 S/N	型号理论重量 JMA Code & KG/M	型材图 Drawing	序号 S/N	型号理论重量 JMA Code & KG/M	型材图 Drawing
1	框料 PM5561 1.320kg/m		10			19		
2	扇料 PM5563 1.665kg/m		11			20		
3	压线 PM5564 0.255kg/m		12			21		
4	PM5565 0.417kg/m		13			22		
5			14			23		
6			15			24		
7			16			25		
8			17			26		
9			18			27		

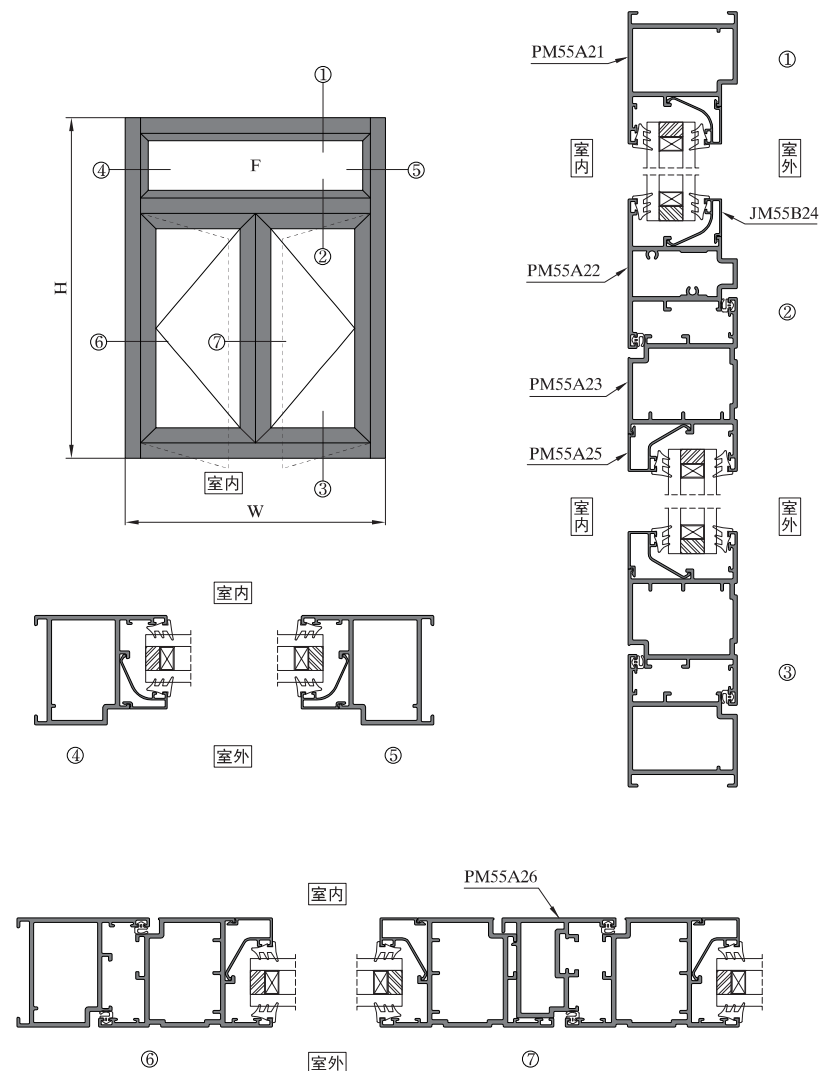

序号 S/N	型号理论重量 JMA Code & KG/M	型材图 Drawing	序号 S/N	型号理论重量 JMA Code & KG/M	型材图 Drawing	序号 S/N	型号理论重量 JMA Code & KG/M	型材图 Drawing
1	框料 PM55A21 T=2.20 1.445kg/m		9	转角 PM55A27 T=2.20 1.388kg/m		18		
2	中挺 PM55A22 T=2.20 1.562kg/m		10	角码 JMGR7598 3.187kg/m		19		
3	加强中挺 PM55A22A T=2.20 2.505kg/m		11			20		
			12			21		
4	加强中挺 PM55A22C T=2.50 3.861kg/m		13			22		
5	扇料 PM55A23 T=2.20 1.702kg/m		14			23		
6	假中挺 PM55A26 T=2.20 1.337kg/m		15			24		
7	框压线 JM55B24 T=0.9 0.202kg/m		16			25		
8	扇压线 PM55A25 T=1.0 0.239kg/m		17			26		

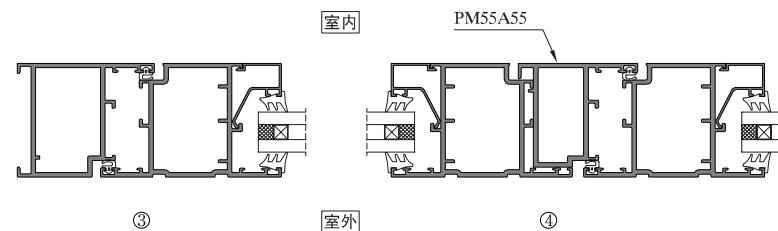
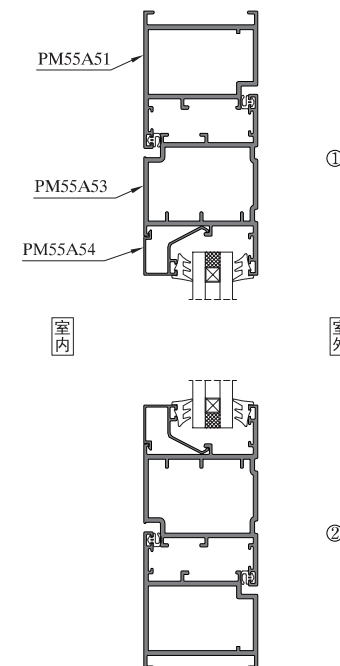
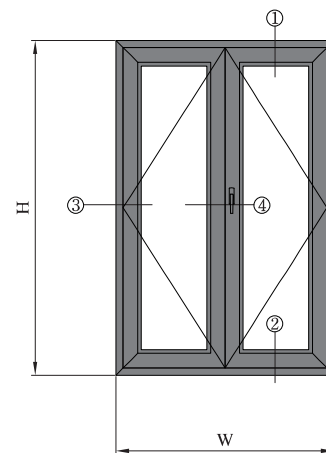

序号 S/N	型号理论重量 JMA Code & KG/M	型材图 Drawing	序号 S/N	型号理论重量 JMA Code & KG/M	型材图 Drawing	序号 S/N	型号理论重量 JMA Code & KG/M	型材图 Drawing
1	框料 PM55A51 T=2.20 1.433kg/m		10			19		
2	框料 PM55A51A T=2.20 1.298kg/m		11			20		
3	框料 PM55A51B T=2.20 1.121kg/m		12			21		
4	框料 PM55A51C T=2.20 0.862kg/m		13			22		
5	扇料 PM55A53 T=2.20 1.686kg/m		14			23		
6	压线 PM55A54 T=1.00 0.239kg/m		15			24		
7	假中挺 PM55A55 T=2.20 1.236kg/m		16			25		
8	角码 JMGR3575 T=3.00 3.470kg/m		17			26		
9			18			27		

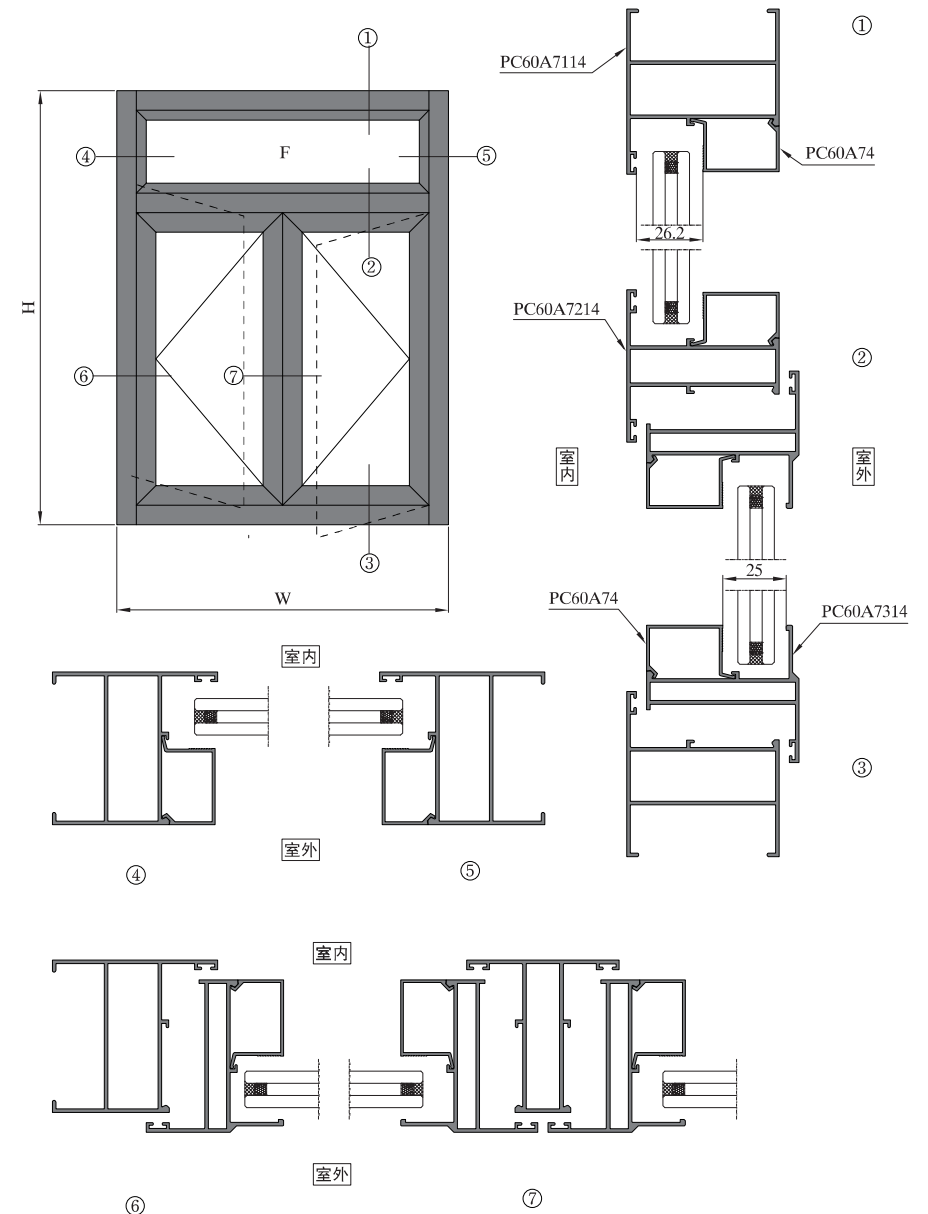

序号 S/N	型号理论重量 JMA Code & KG/M	型材图 Drawing	序号 S/N	型号理论重量 JMA Code & KG/M	型材图 Drawing	序号 S/N	型号理论重量 JMA Code & KG/M	型材图 Drawing
1	PC60A7114 1.001kg/m		10	PC5026B 1.096kg/m		19		
2	PC60A71A20 1.358kg/m		11	JMGR5236 7.735kg/m		20		
3	PC60A7214 0.908kg/m		12			21		
4	PC60A72A20 1.211kg/m		13			22		
5	PC60A7314 0.820kg/m		14			23		
6	PC60A73A20 1.480kg/m		15			24		
7	PC60A74 0.249kg/m		16			25		
8	PC60A75 0.907kg/m		17			26		
9	JMGR5008 2.351kg/m		18			27		

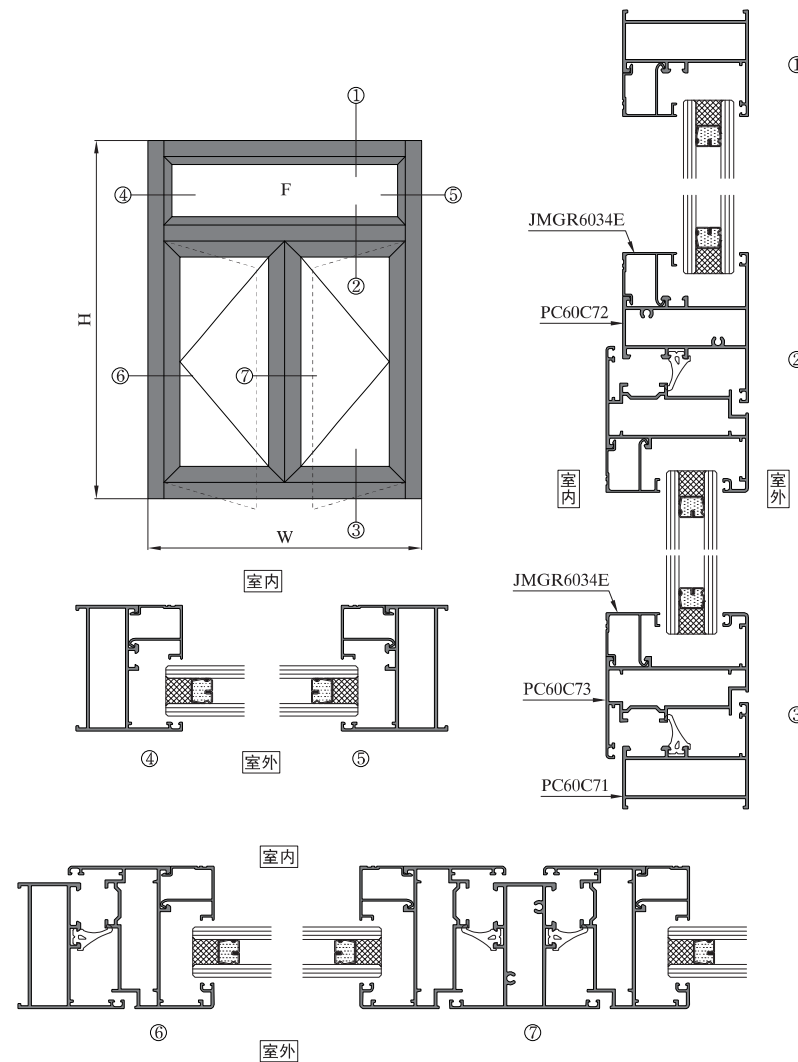

序号 S/N	型号理论重量 JMA Code & KG/M	型材图 Drawing	序号 S/N	型号理论重量 JMA Code & KG/M	型材图 Drawing	序号 S/N	型号理论重量 JMA Code & KG/M	型材图 Drawing
1	框料 PC60C71 0.910kg/m		10			19		
2	中挺 PC60C72 1.144kg/m		11			20		
3	加强中挺 PC60C72A 2.092kg/m		12			21		
4	扇料 PC60C73 1.190kg/m		13			22		
5	压线 JMGR6034RX 0.292kg/m		14			23		
6	压线 JM5534A09 0.269kg/m		15			24		
7	压线 JMGR6034E 0.254kg/m		16			25		
8	角码 JMGR6036 2.278kg/m		17			26		
9			18			27		

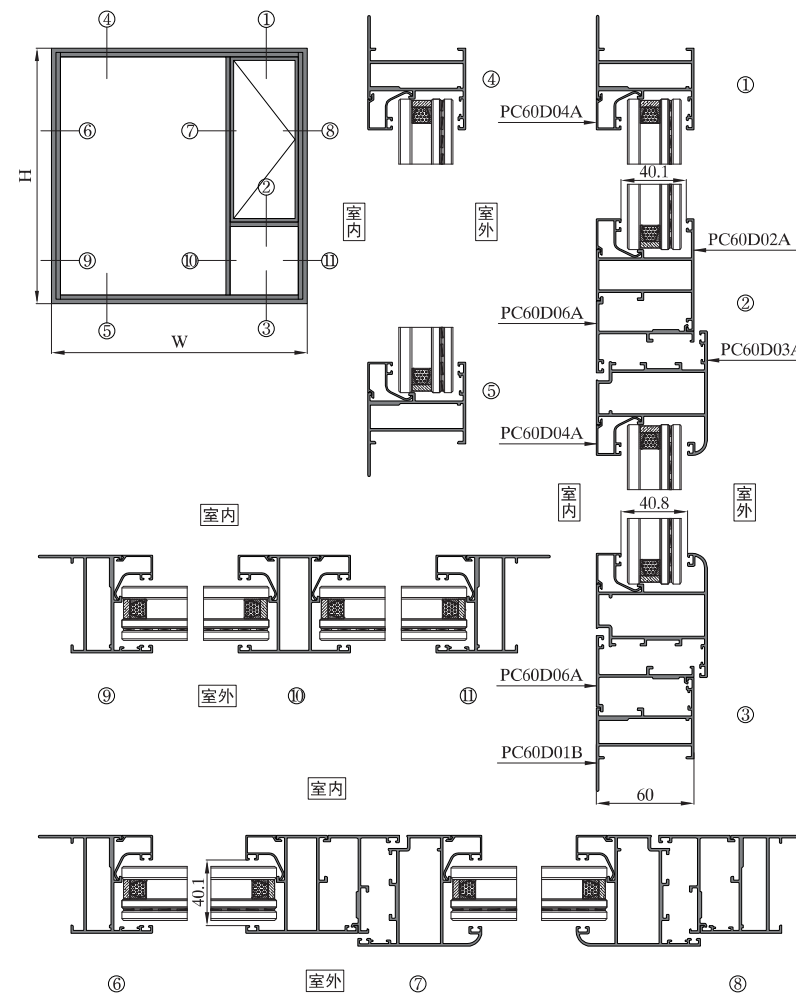

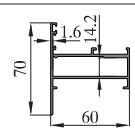
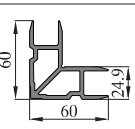
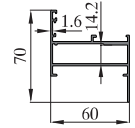
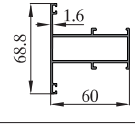
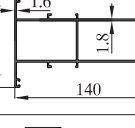
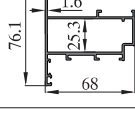
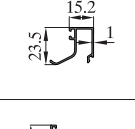
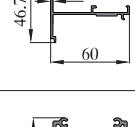
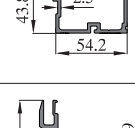
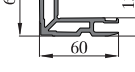
序号 S/N	型号理论重量 JMA Code & KG/M	型材图 Drawing	序号 S/N	型号理论重量 JMA Code & KG/M	型材图 Drawing	序号 S/N	型号理论重量 JMA Code & KG/M	型材图 Drawing
1	窗框 PC60D01A 1.166kg/m		10	角码 JMGR55B47B 2.146kg/m		19		
2	窗框 PC60D01B 1.166kg/m		11			20		
3	中挺 PC60D02A 1.119kg/m		12			21		
4	中挺 PC60D02B 2.415kg/m		13			22		
5	窗扇 PC60D03A 1.412kg/m		14			23		
6	压线 PC60D04A 0.232kg/m		15			24		
7	转换框 PC60D06A 0.647kg/m		16			25		
8	连接件 PC60D07A 1.293kg/m		17			26		
9	角码 JMGR55B47 1.988kg/m		18			27		

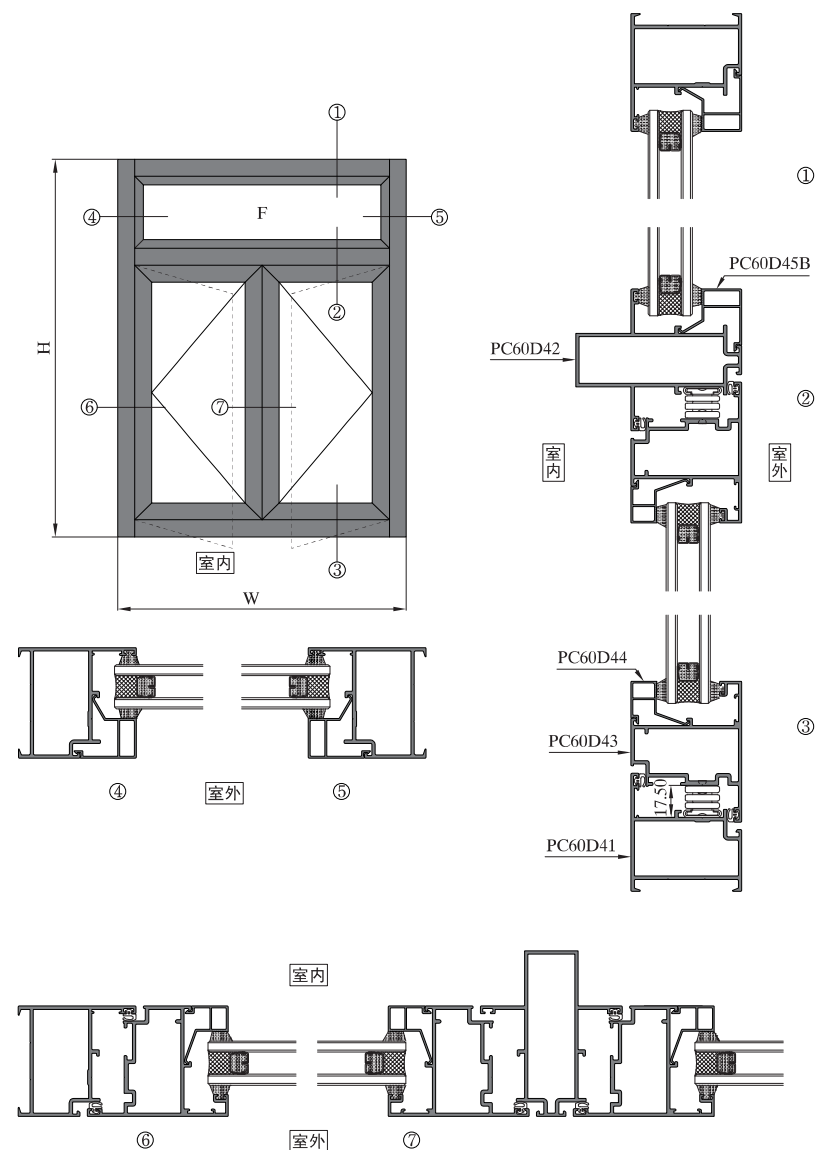

序号 S/N	型号理论重量 JMA Code & KG/M	型材图 Drawing	序号 S/N	型号理论重量 JMA Code & KG/M	型材图 Drawing	序号 S/N	型号理论重量 JMA Code & KG/M	型材图 Drawing
1	框料 PC60D41 1.267kg/m		10			19		
2	中挺 PC60D42 1.646kg/m		11			20		
3	中挺 PC60D42A 3.508kg/m		12			21		
4	扇料 PC60D43 1.470kg/m		13			22		
5	转角 PC60D46 2.017kg/m		14			23		
6	扇压线 PC60D44 0.261kg/m		15			24		
7	框压线 PC60D45A 0.310kg/m		16			25		
8	框压线 PC60D45B 0.323kg/m		17			26		
9			18			27		

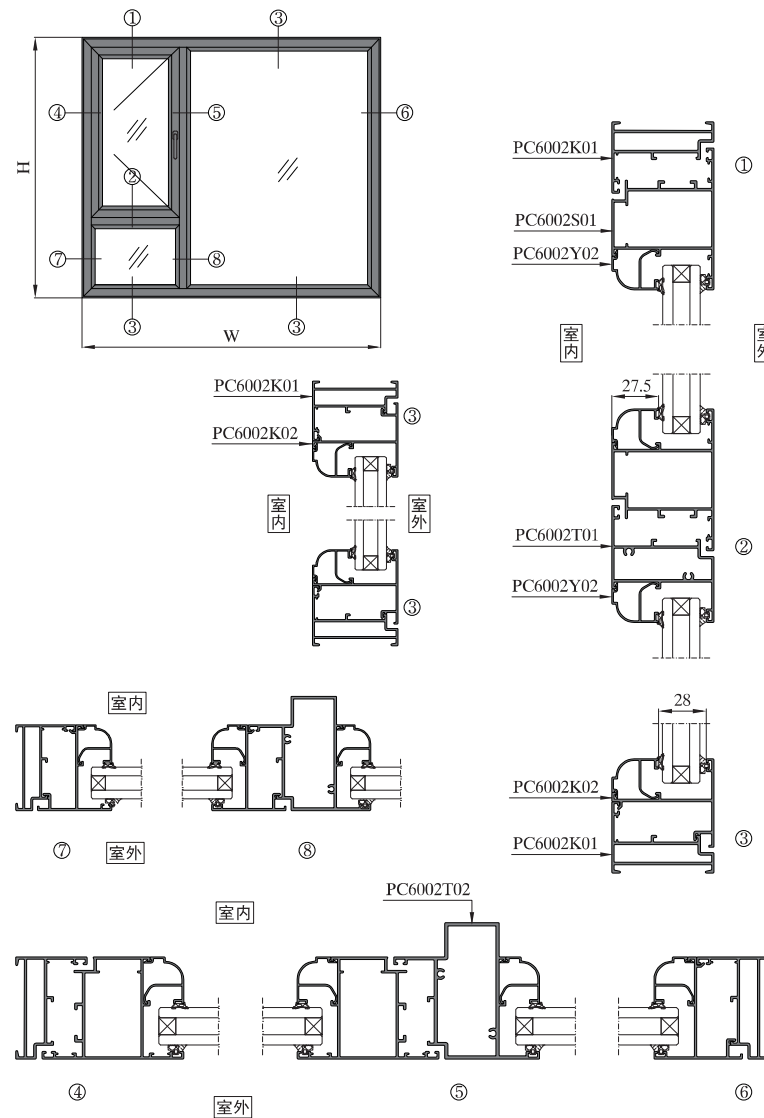

序号 S/N	型号理论重量 JMA Code & KG/M	型材图 Drawing	序号 S/N	型号理论重量 JMA Code & KG/M	型材图 Drawing	序号 S/N	型号理论重量 JMA Code & KG/M	型材图 Drawing
1	窗框 PC6002K01 0.821kg/m		10	压线 PC6002Y05 0.202kg/m		19	转换框 PC6001J01 0.735kg/m	
2	转换框 PC6002K02 0.605kg/m		11	压线 JM50D14J 0.219kg/m		20	角码 JM50D16D 3.488kg/m	
3	中挺 PC6002T01 1.048kg/m		12	压线 JM50D14K 0.217kg/m		21	角码 JMGR7598 3.187kg/m	
4	中挺 PC6002T02 1.648kg/m		13	压线 JM50D14L 0.272kg/m		22	角码 JM50D16C 0.988kg/m	
5	扇料 PC6002S01 1.176kg/m		14	转角 PC6002J01 1.859kg/m		23	角码 PC5026B 1.096kg/m	
6	压线 PC6002Y01 0.233kg/m		15	窗框 PC6001K02 1.018kg/m		24		
7	压线 PC6002Y02 0.245kg/m		16	中挺 PC6001T02 1.285kg/m		25		
8	压线 PC6002Y03 0.248kg/m		17	边框 PC6001T01 1.874kg/m		26		
9	压线 PC6002Y04 0.204kg/m		18	扇料 PC6001S01 1.446kg/m		27		

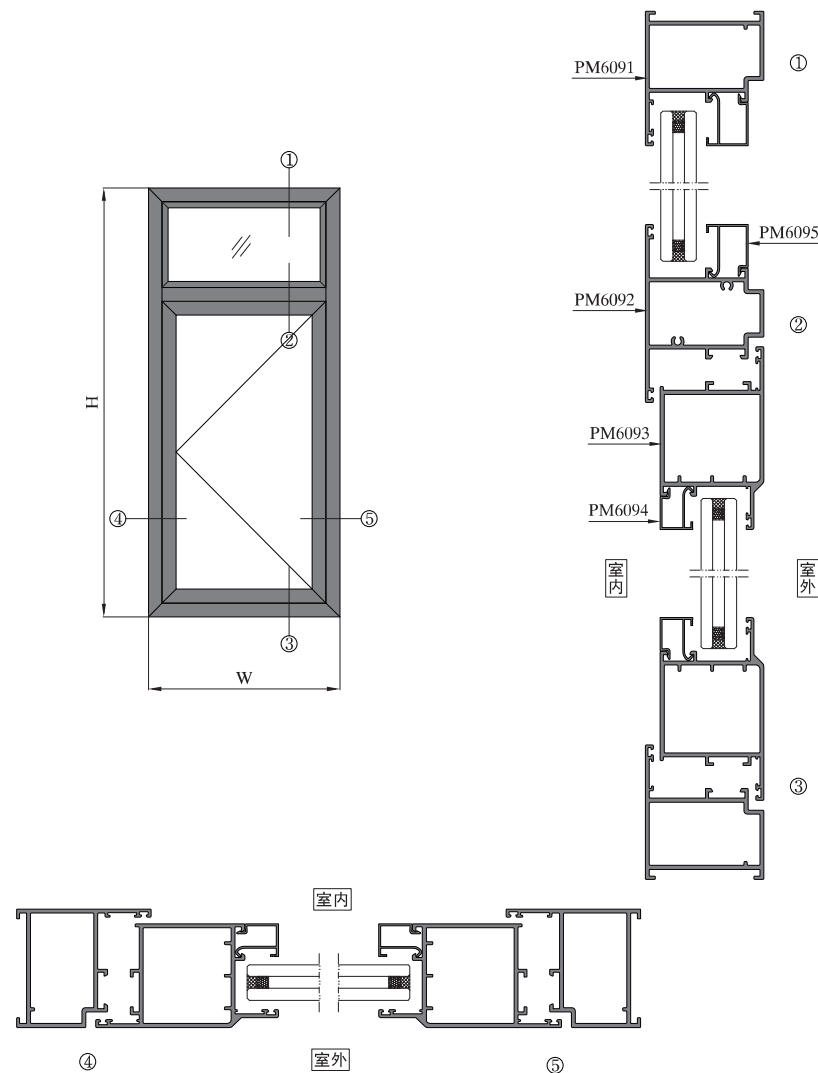

图中所示型材截面、装配、编号、尺寸及重量仅供参考。如有疑问，请向本公司查询。
Information above just for your reference. Please contact us if you have any questions, Thank you!

图中所示型材截面、装配、编号、尺寸及重量仅供参考。如有疑问，请向本公司查询。
Information above just for your reference. Please contact us if you have any questions, Thank you!

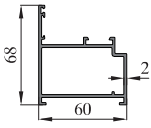
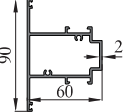
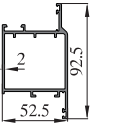
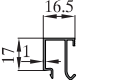
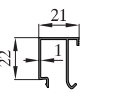
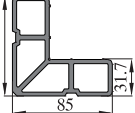
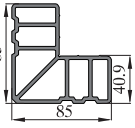
序号 S/N	型号理论重量 JMA Code & KG/M	型材图 Drawing	序号 S/N	型号理论重量 JMA Code & KG/M	型材图 Drawing	序号 S/N	型号理论重量 JMA Code & KG/M	型材图 Drawing
1	框料 PM6091 1.415kg/m		10			19		
2	中挺 PM6092 1.621kg/m		11			20		
3	扇料 PM6093 1.612kg/m		12			21		
4	扇料 PM6094 0.198kg/m		13			22		
5	压线 PM6095 0.241kg/m		14			23		
6	角码 JMGR6059A 4.263kg/m		15			24		
7	角码 PM5567B 4.487kg/m		16			25		
8			17			26		
9			18			27		

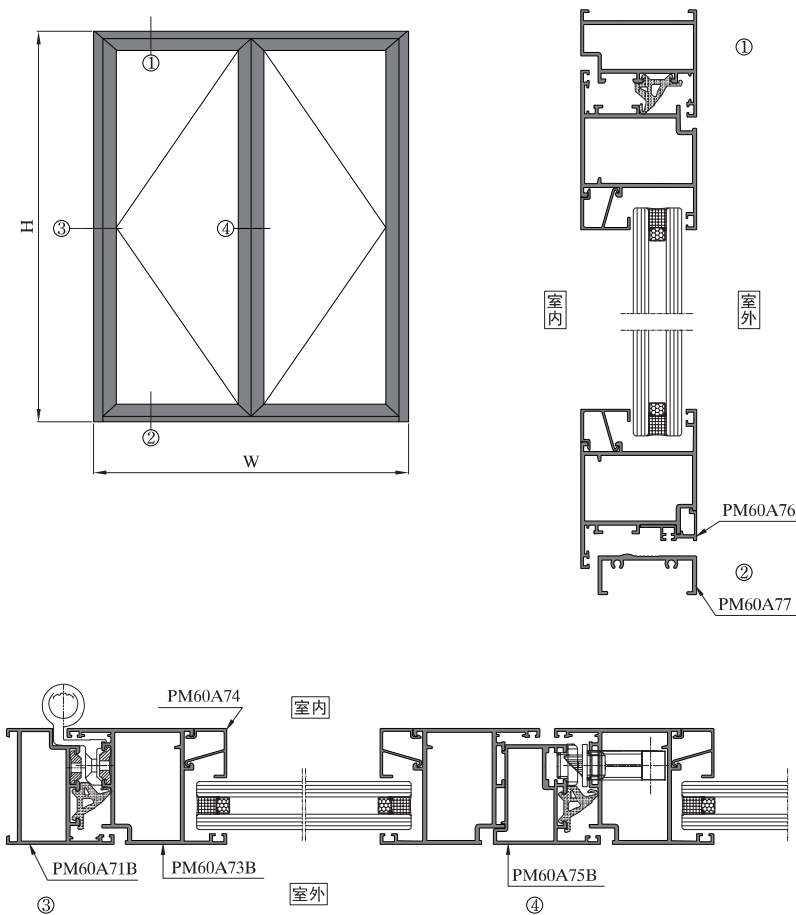

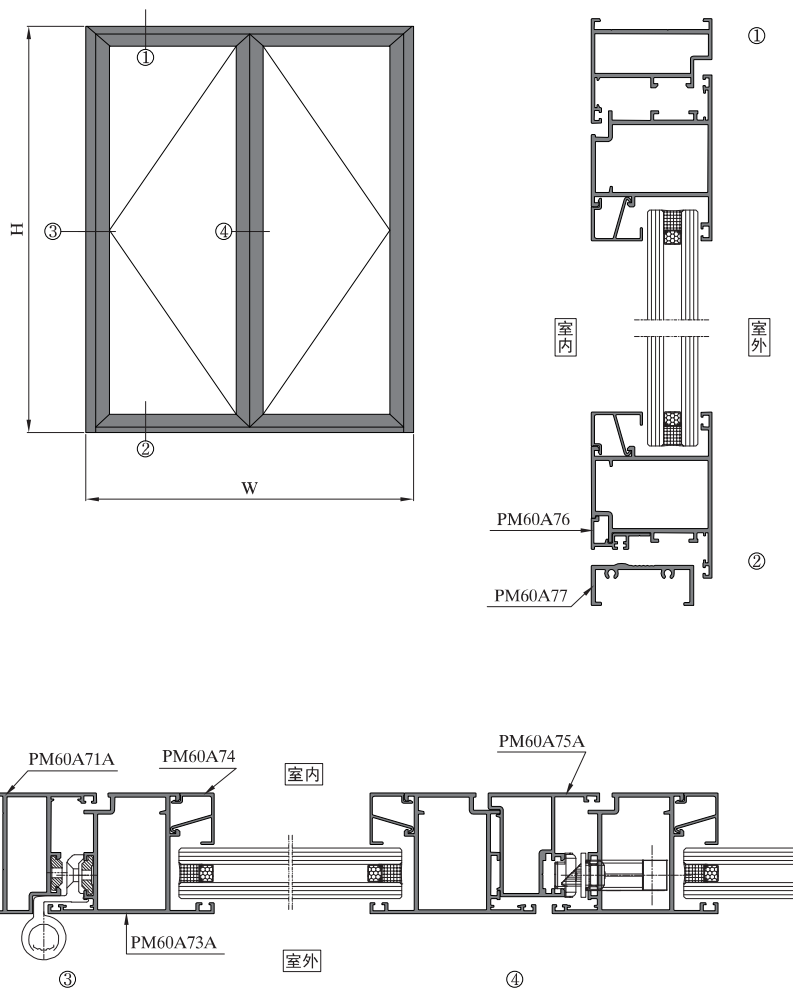

序号 S/N	型号理论重量 JMA Code & KG/M	型材图 Drawing	序号 S/N	型号理论重量 JMA Code & KG/M	型材图 Drawing	序号 S/N	型号理论重量 JMA Code & KG/M	型材图 Drawing
1	PM60A71A 1.177kg/m		10			19		
2	PM60A71B 1.254kg/m		11			20		
3	PM60A73A 1.589kg/m		12			21		
4	PM60A73B 1.587kg/m		13			22		
5	PM60A74 0.278kg/m		14			23		
6	PM60A74A 1.071kg/m		15			24		
7	PM60A75B 1.125kg/m		16			25		
8	PM60A76 0.261kg/m		17			26		
9	PM60A77 0.626kg/m		18			27		

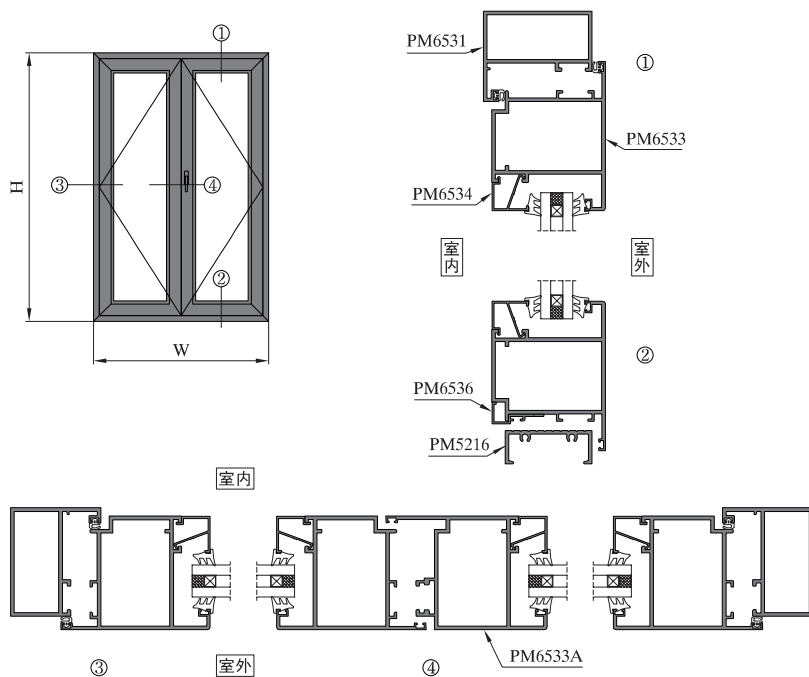

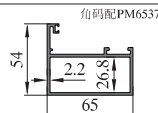
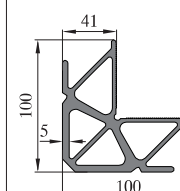
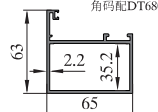
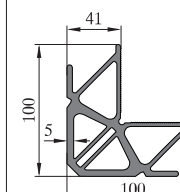
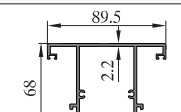
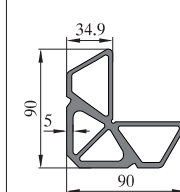
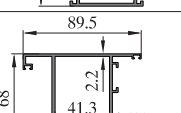
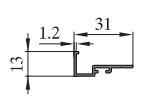
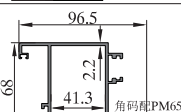
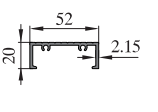
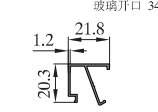
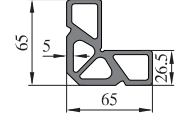
序号 S/N	型号理论重量 JMA Code & KG/M	型材图 Drawing	序号 S/N	型号理论重量 JMA Code & KG/M	型材图 Drawing	序号 S/N	型号理论重量 JMA Code & KG/M	型材图 Drawing
1	框料 PM6531 T=2.20 1.441kg/m	角码配PM6537A 	10	角码 PM6537 T=5.00 5.815kg/m		16		
2	框料 PM6531A T=2.20 1.598kg/m	角码配DT6802 	11	角码 PM6537D T=5.00 6.021kg/m		17		
3	中挺 PM6538 T=2.20 2.061kg/m		12	角码 DT6802 T=3.00 4.977kg/m		18		
4	扇料 PM6533 T=2.20 1.917kg/m	角码配PM6537 或PM6537D 	13	密封条 PM6536 T=1.20 0.190kg/m		19		
5	假中挺 PM6533A T=2.20 2.071kg/m	角码配PM6537 或PM6537D 	14	门槛 PM5216 T=2.15 0.643kg/m		20		
6	压线 PM6534 T=1.20 0.233kg/m	玻璃开口 34.0 	15	角码 PM6537A T=3.00 3.738kg/m		21		
7	密封条 PM6536 T=1.20 0.190kg/m		22			22		
8	门槛 PM5216 T=2.15 0.643kg/m		23			23		
9	角码 PM6537A T=3.00 3.738kg/m		24			24		

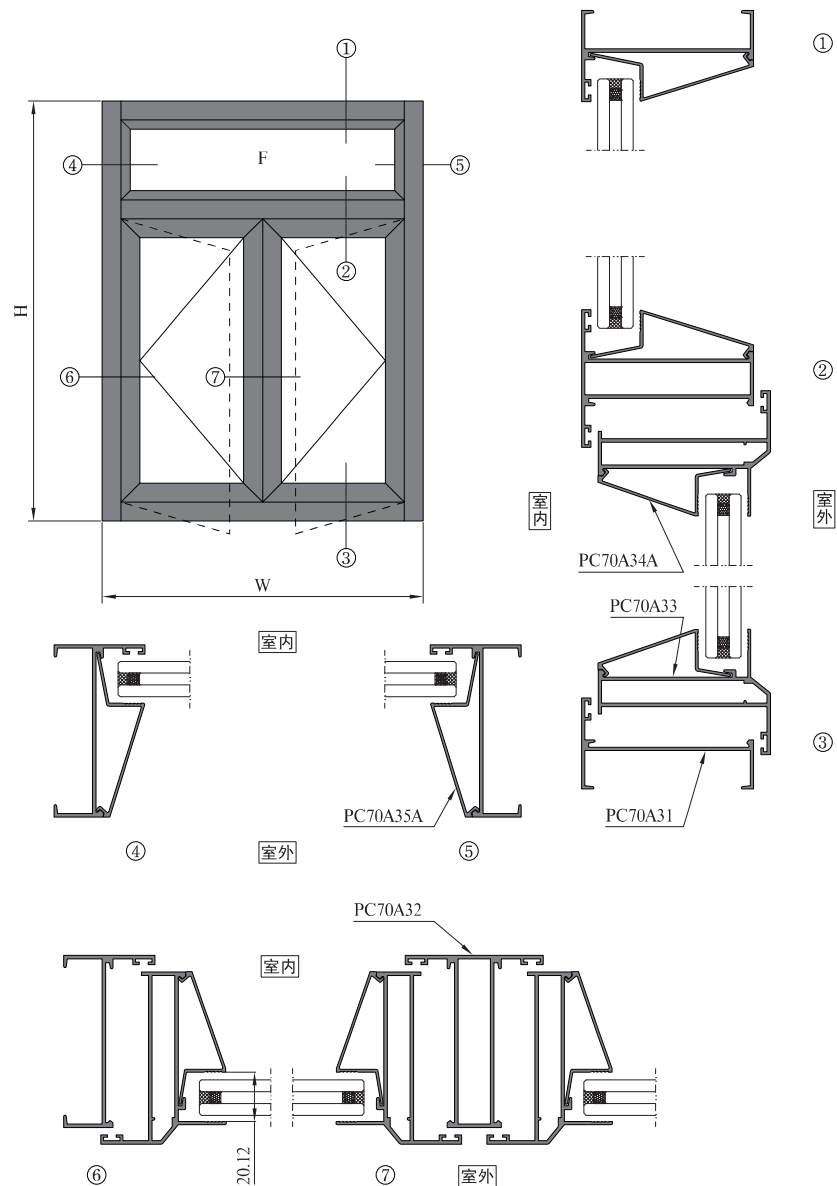

序号 S/N	型号理论重量 JMA Code & KG/M	型材图 Drawing	序号 S/N	型号理论重量 JMA Code & KG/M	型材图 Drawing	序号 S/N	型号理论重量 JMA Code & KG/M	型材图 Drawing
1	PC70A31 0.588kg/m		10	框压线 PC70A35 0.286kg/m	玻璃开口10mm 	19		
2	PC70A32 0.980kg/m		11	框压线 PC70A35A 0.272kg/m	玻璃开口20mm 	20		
3	PC70A33 0.873kg/m		12	框压线 PC70A35B 0.281kg/m	玻璃开口27mm 	21		
4	扇压线 PC70A34 0.246kg/m	玻璃开口10mm 	13	框压线 PC70A35C 0.280kg/m	玻璃开口24mm 	22		
5	扇压线 PC70A34A 0.241kg/m	玻璃开口20mm 	14	PC70A36 1.310kg/m		23		
6	扇压线 PC70A34B 0.245kg/m	玻璃开口27mm 	15	PC70A36A 1.309kg/m		24		
7	扇压线 PC70A34C 0.243kg/m	玻璃开口24mm 	16	PC70A36B 1.562kg/m		25		
8	扇压线 PC70A34D 0.294kg/m	玻璃开口9mm 	17			26		
9	扇压线 PC70A34E 0.273kg/m	玻璃开口24mm 	18			27		

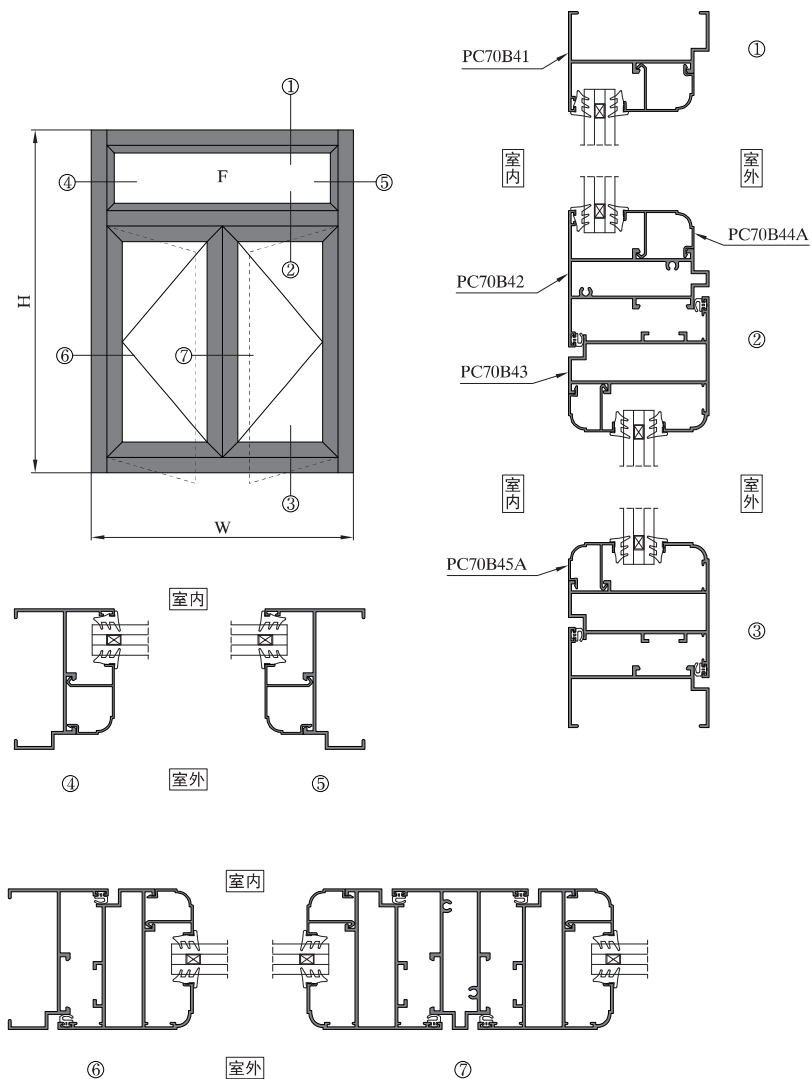

序号 S/N	型号理论重量 JMA Code & KG/M	型材图 Drawing	序号 S/N	型号理论重量 JMA Code & KG/M	型材图 Drawing	序号 S/N	型号理论重量 JMA Code & KG/M	型材图 Drawing
1	框料 PC70B41 0.703kg/m		10	角码 JMGR41150 2.915kg/m		19		
2	转角 PC70B41A 1.388kg/m		11			20		
3	中挺 PC70B42 1.165kg/m		12			21		
4	扇料 PC70B43 1.175kg/m		13			22		
5	框压线 PC70B44 0.306kg/m		14			23		
6	框压线 PC70B44A 0.262kg/m		15			24		
7	扇压线 PC70B45 0.269kg/m		16			25		
8	扇压线 PC70B45A 0.224kg/m		17			26		
9	连轩 JMGR5507A 0.153kg/m		18			27		

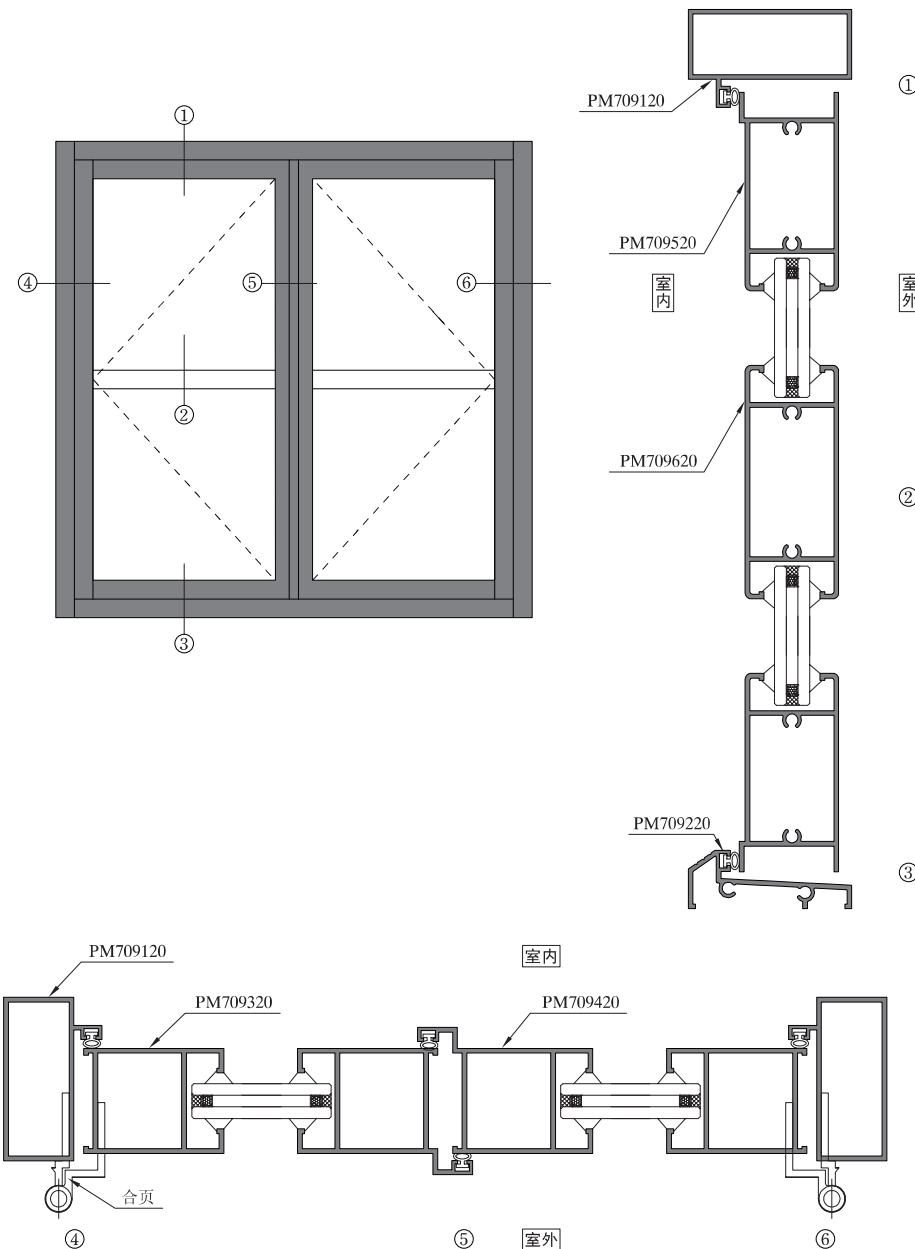
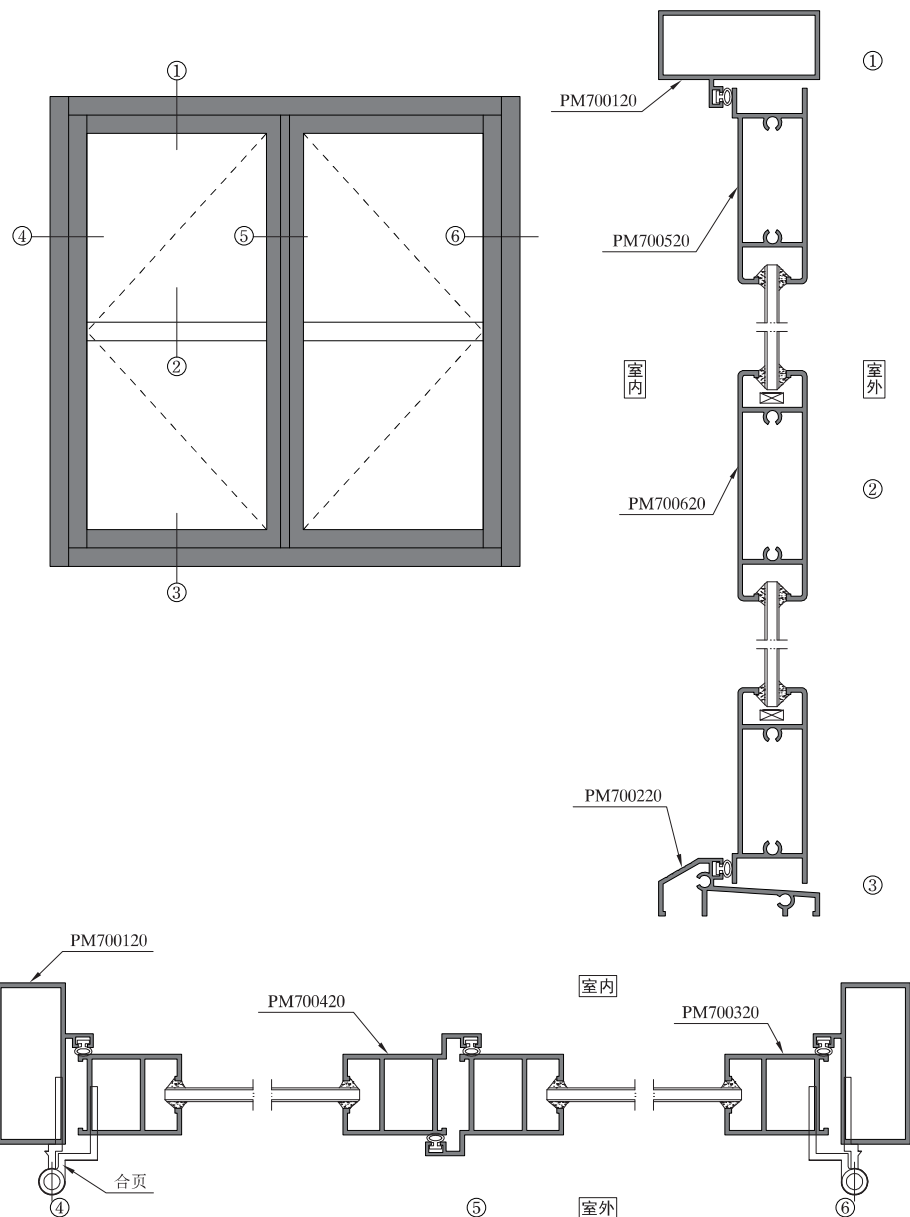

序号 S/N	型号理论重量 JMA Code & KG/M	型材图 Drawing	序号 S/N	型号理论重量 JMA Code & KG/M	型材图 Drawing	序号 S/N	型号理论重量 JMA Code & KG/M	型材图 Drawing
1	框料 PM700114 0.892kg/m		10	框料 PM7002A14 0.717kg/m		19	扇料 PM7004A14 0.843kg/m	
2	框料 PM700120 1.225kg/m		11	扇料 PM700314 0.742kg/m		20	扇料 PM7004B14 0.821kg/m	
3	框料 PM7001A14 0.917kg/m		12	扇料 PM700320 1.025kg/m		21	扇料 PM7004C14 1.207kg/m	
4	框料 PM7001A20 1.260kg/m		13	扇料 PM7003A14 1.069kg/m		22	扇料 PM7004D14 1.044kg/m	
5	框料 PM7001B14 1.138kg/m		14	扇料 PM7003B14 0.705kg/m		23	扇料 PM700514 1.107kg/m	
6	框料 PM7001B20 1.576kg/m		15	扇料 PM7003D14 0.696kg/m		24	扇料 PM700520 1.486kg/m	
7	框料 PM7001D14 0.987kg/m		16	扇料 PM7003E14 1.028kg/m		25	扇料 PM7005A14 1.070kg/m	
8	框料 PM700214 0.656kg/m		17	扇料 PM700414 0.880kg/m		26	扇料 PM7005B14 1.044kg/m	
9	框料 PM700220 0.828kg/m		18	扇料 PM700420 1.190kg/m		27	扇料 PM700614 1.290kg/m	

序号 S/N	型号理论重量 JMA Code & KG/M	型材图 Drawing	序号 S/N	型号理论重量 JMA Code & KG/M	型材图 Drawing	序号 S/N	型号理论重量 JMA Code & KG/M	型材图 Drawing
1	门中横 PM700620 1.734kg/m		10	扇料 PM709320 1.306kg/m		19		
2	门中横 PM7006B14 1.215kg/m		11	扇料 PM7093A20 1.376kg/m		20		
3	门中横 PM7006C14 1.163kg/m		12	扇料 PM709420 1.471kg/m		21		
4	框料 PM700715 0.518kg/m		13	扇料 PM7094A20 1.541kg/m		22		
5	框料 PM700812 0.877kg/m		14	扇料 PM709520 1.590kg/m		23		
6	框料 PM7008A14 1.234kg/m		15	扇料 PM7095A20 1.660kg/m		24		
7	框料 PM7008B16 1.712kg/m		16	门中横 PM709620 1.826kg/m		25		
8	框料 PM709120 1.225kg/m		17	门中横 PM7096A20 1.967kg/m		26		
9	框料 PM709220 0.777kg/m		18			27		

图中所示型材截面、装配、编号、尺寸及重量仅供参考。如有疑问，请向本公司查询。
 Information above just for your reference. Please contact us if you have any questions, Thank you!

图中所示型材截面、装配、编号、尺寸及重量仅供参考。如有疑问，请向本公司查询。
 Information above just for your reference. Please contact us if you have any questions, Thank you!

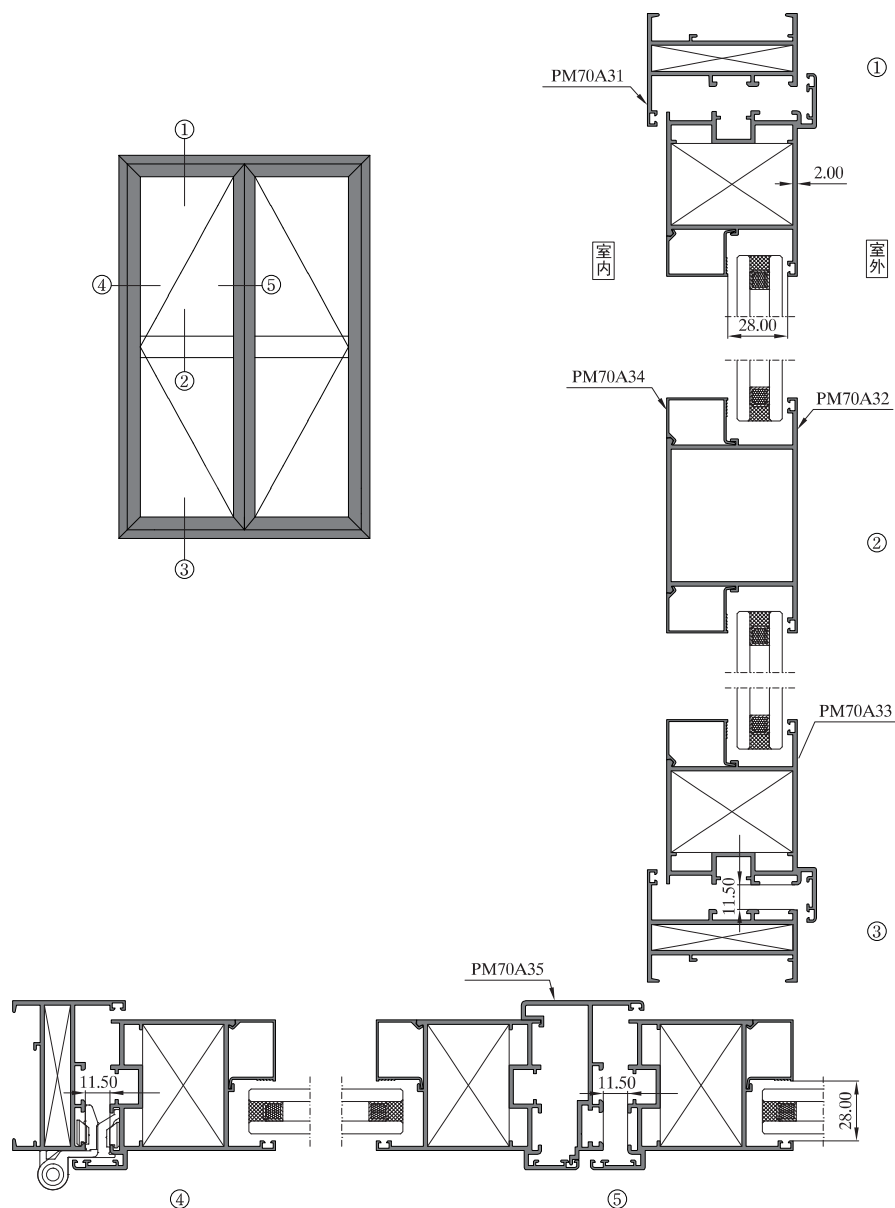

序号 S/N	型号理论重量 JMA Code & KG/M	型材图 Drawing	序号 S/N	型号理论重量 JMA Code & KG/M	型材图 Drawing	序号 S/N	型号理论重量 JMA Code & KG/M	型材图 Drawing
1	框料 PM70A31 1.430kg/m	角码配JMGR5706 52.6 2 70 3.4	10			19		
2	中挺 PM70A32 (门中横) 1.797kg/m	72.4 61 2 110	11			20		
3	扇料 PM70A33 1.906kg/m	61 角码配JMGR5236 94.8 2 38 58 70	12			21		
4	压线 PM70A34 0.230kg/m	玻璃开口28mm 28.5 1 18.8	13			22		
5	转换料 PM70A35 1.080kg/m	57.2 2 76.8	14			23		
6	角码 JMGR5706 1.874kg/m	11.9 45 11.9 45	15			24		
7	角码 JMGR5236 7.735kg/m	90 90 37.7	16			25		
8			17			26		
9			18			27		

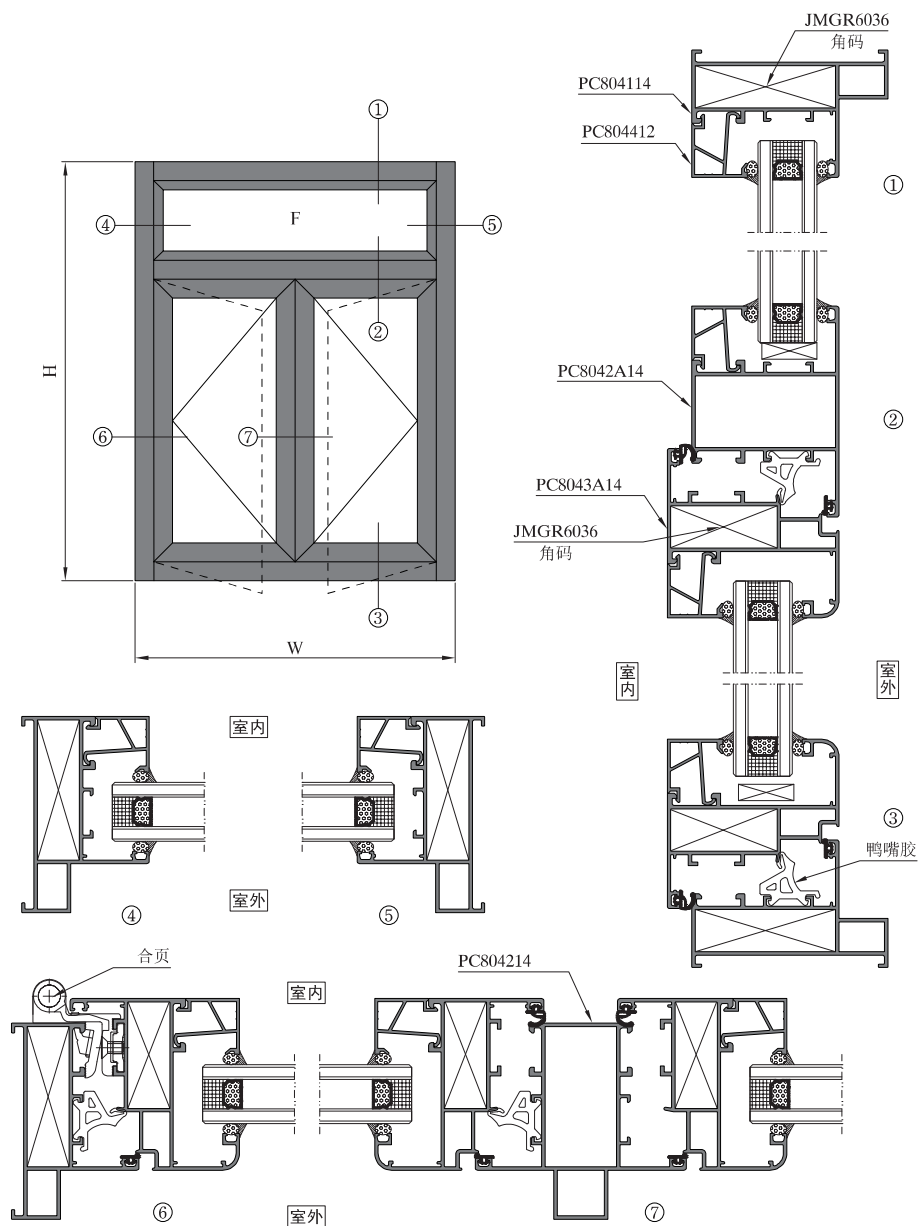

序号 S/N	型号理论重量 JMA Code & KG/M	型材图 Drawing	序号 S/N	型号理论重量 JMA Code & KG/M	型材图 Drawing	序号 S/N	型号理论重量 JMA Code & KG/M	型材图 Drawing
1	框料 PC804114 1.176kg/m		10			19		
2	中挺 PC804214 1.493kg/m		11			20		
3	中挺 PC8042A14 1.251kg/m		12			21		
4	扇料 PC804314 1.230kg/m		13			22		
5	扇料 PC8043A14 1.244kg/m		14			23		
6	压线 PC804412 0.348kg/m		15			24		
7	压线 PC8044A12 0.334kg/m		16			25		
8	角码 JMGR6036 2.278kg/m		17			26		
9			18			27		

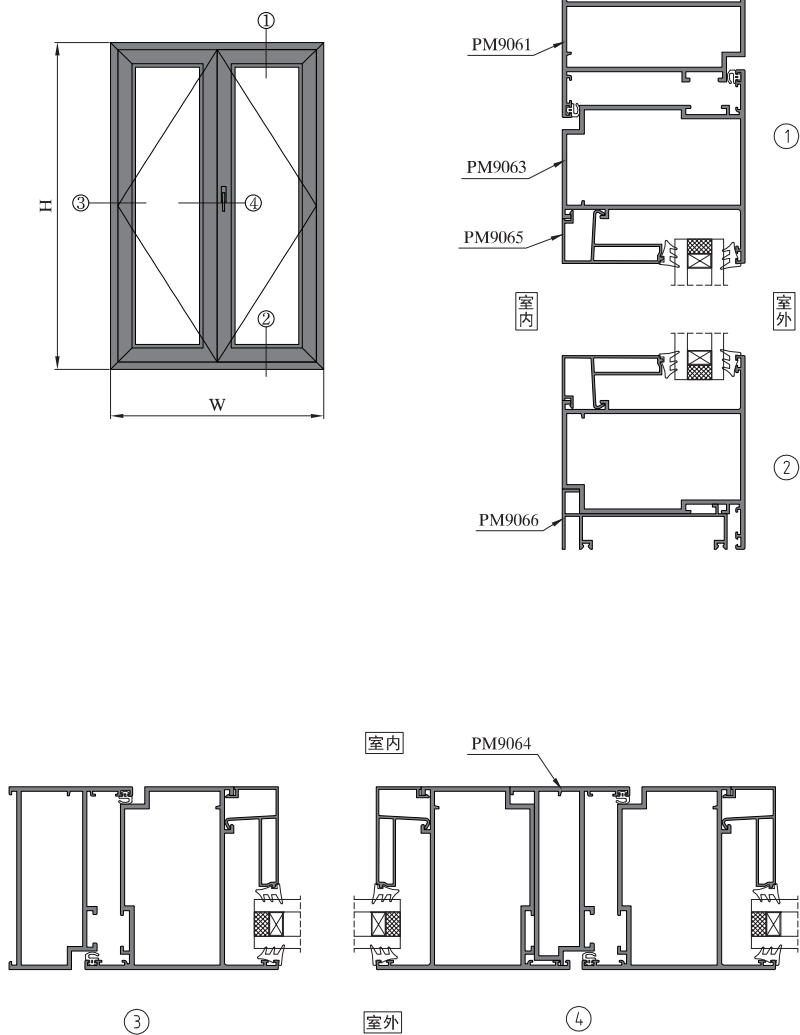

序号 S/N	型号理论重量 JMA Code & KG/M	型材图 Drawing	序号 S/N	型号理论重量 JMA Code & KG/M	型材图 Drawing	序号 S/N	型号理论重量 JMA Code & KG/M	型材图 Drawing
1	框料 PM9061 T=2.20 1.872kg/m		8			17		
2	扇料 PM9063 T=2.20 2.243kg/m		9			18		
			10			19		
3	假中挺 PM9064 T=2.20 1.716kg/m		11			20		
4	压线 PM9065 T=2.20 0.525kg/m		12			21		
5	辅件 PM9066 T=1.40 0.698kg/m		13			22		
6	框角码 PC4627 2.646kg/m		14			23		
7	扇角码 JMGR5249 7.907kg/m		15			24		
			16			25		

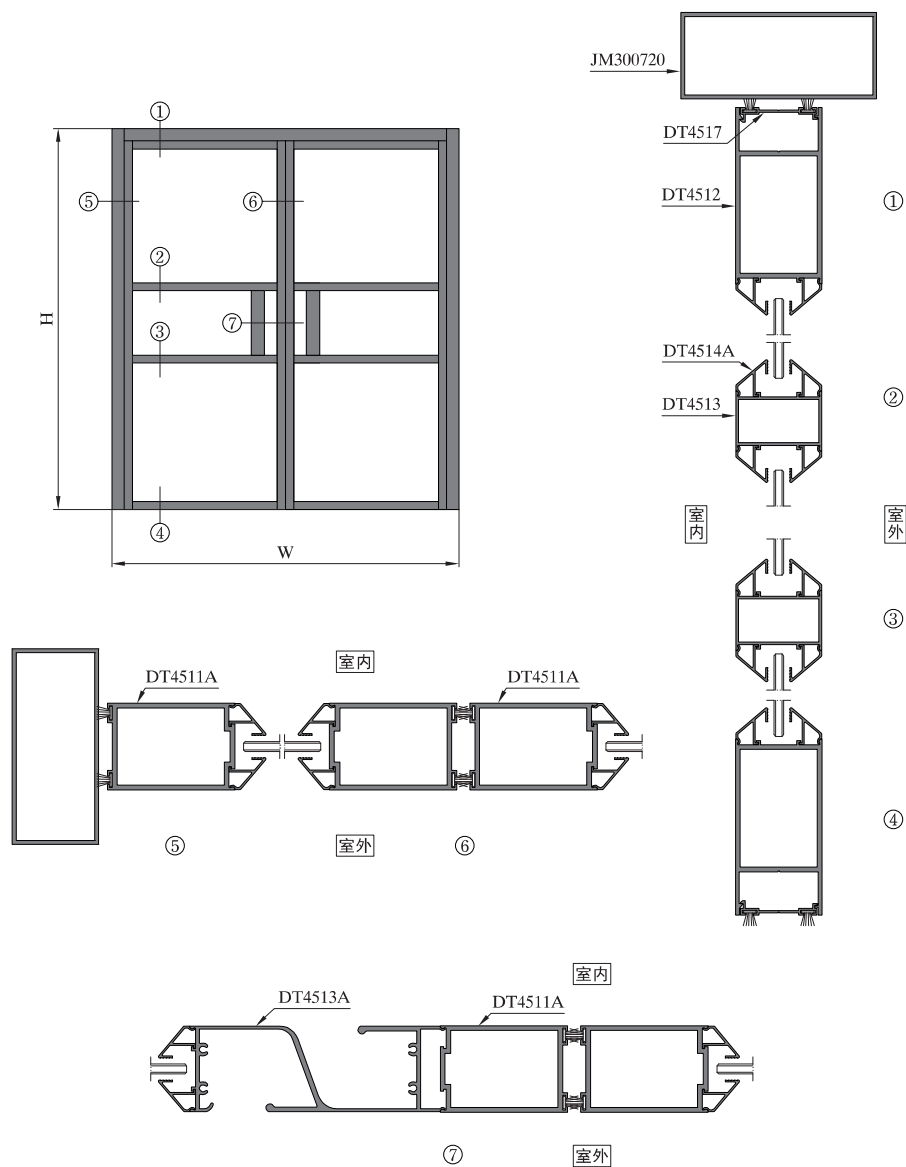

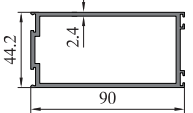
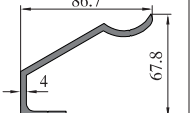
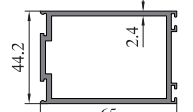
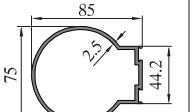
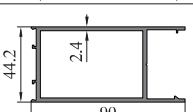
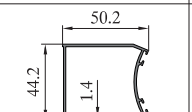
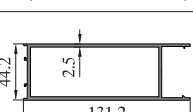
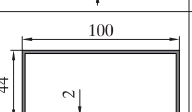
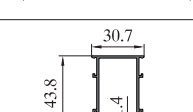
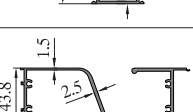
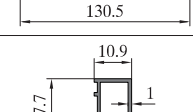
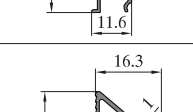
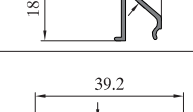
序号 S/N	型号理论重量 JMA Code & KG/M	型材图 Drawing	序号 S/N	型号理论重量 JMA Code & KG/M	型材图 Drawing	序号 S/N	型号理论重量 JMA Code & KG/M	型材图 Drawing
1	光企 DT4511 1.871kg/m		10	拉手 DT4517A 1.792kg/m		19		
2	光企 DT4511A 1.520kg/m		11	光企 DT4517C 1.923kg/m		20		
3	上下方 DT4512 1.766kg/m		12	边框 DT4517D 0.768kg/m		21		
4	上下方 DT4512A 2.436kg/m		13	JM300720 1.639kg/m		22		
5	中横 DT4513 0.616kg/m		14			23		
6	拉手 DT4513A 2.049kg/m		15			24		
7	压线 DT4514 0.126kg/m		16			25		
8	压线 DT4514A 0.132kg/m		17			26		
9	封边 DT4517 0.202kg/m		18			27		

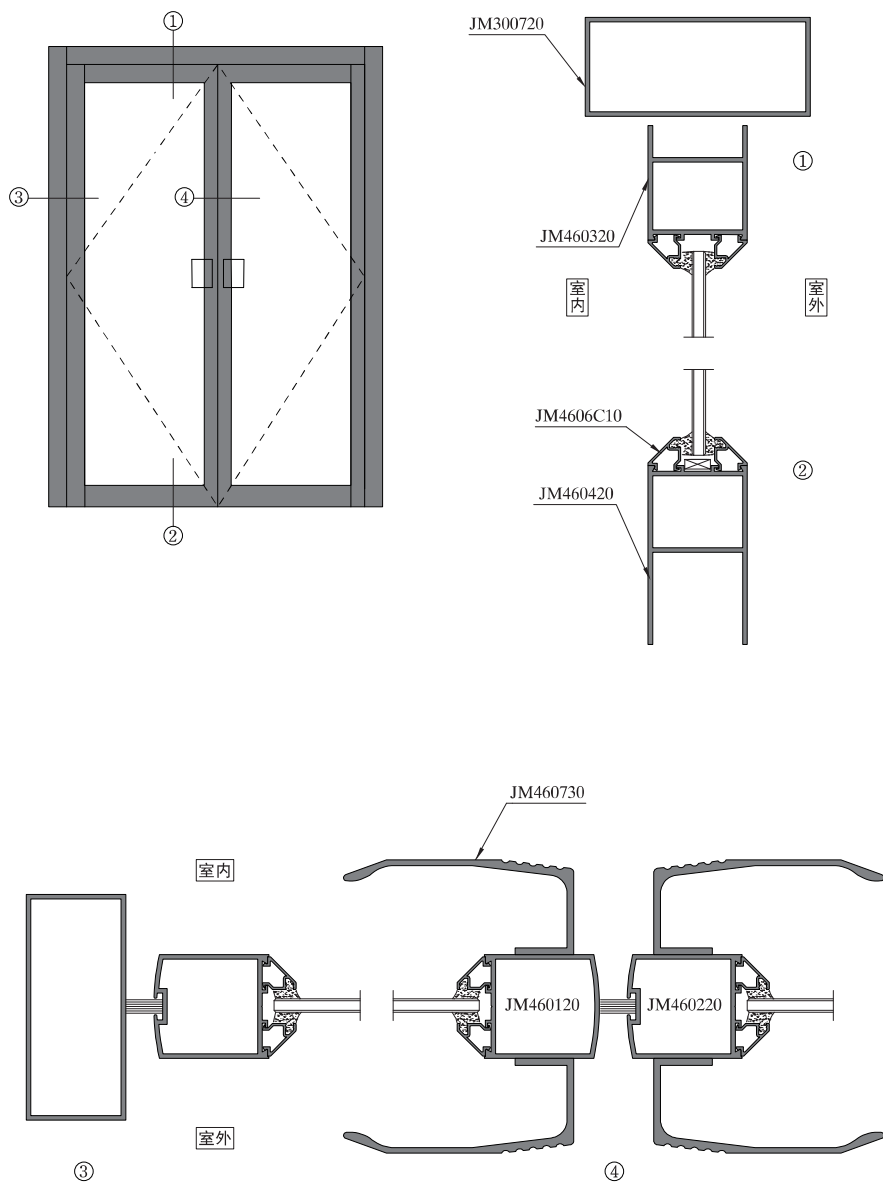

序号 S/N	型号理论重量 JMA Code & KG/M	型材图 Drawing	序号 S/N	型号理论重量 JMA Code & KG/M	型材图 Drawing	序号 S/N	型号理论重量 JMA Code & KG/M	型材图 Drawing
1	扇料 JM460120 1.113kg/m		10	扇料 JM4603D20 1.446kg/m		19	扇压线 JM460610 0.158kg/m	 玻璃开口15mm
2	扇料 JM4601A20 1.135kg/m		11	扇料 JM460420 1.445kg/m		20	扇压线 JM4606A10 0.157kg/m (喷涂专用)	 玻璃开口15mm
3	扇料 JM4601B20 1.518kg/m		12	扇料 JM4604A15 1.916kg/m		21	扇压线 JM4606B10 0.149kg/m	 玻璃开口12mm
4	扇料 JM4601C20 1.233kg/m		13	扇料 JM4604B20 1.445kg/m		22	扇压线 JM4606C10 0.127kg/m	 玻璃开口15mm
5	扇料 JM460220 1.176kg/m		14	扇料 JM4604R 2.594kg/m		23	扇压线 JM4606H12 0.181kg/m	 玻璃开口30mm
6	扇料 JM4602A20 1.565kg/m		15	扇料 JM460914 0.611kg/m		24	扇压线 JM4606R 0.175kg/m	 玻璃开口25mm
7	扇料 JM4602D20 2.337kg/m		16	扇料 JM4609A20 0.846kg/m		25	扇压线 JM4606Y 0.146kg/m	 玻璃开口39mm
8	扇料 JM460320 1.107kg/m		17	扇料 JM4609B20 2.586kg/m		26	把手 JM460730 1.480kg/m	 102
9	扇料 JM4603A20 1.232kg/m		18	扇料 JM461014 1.165kg/m		27		 42

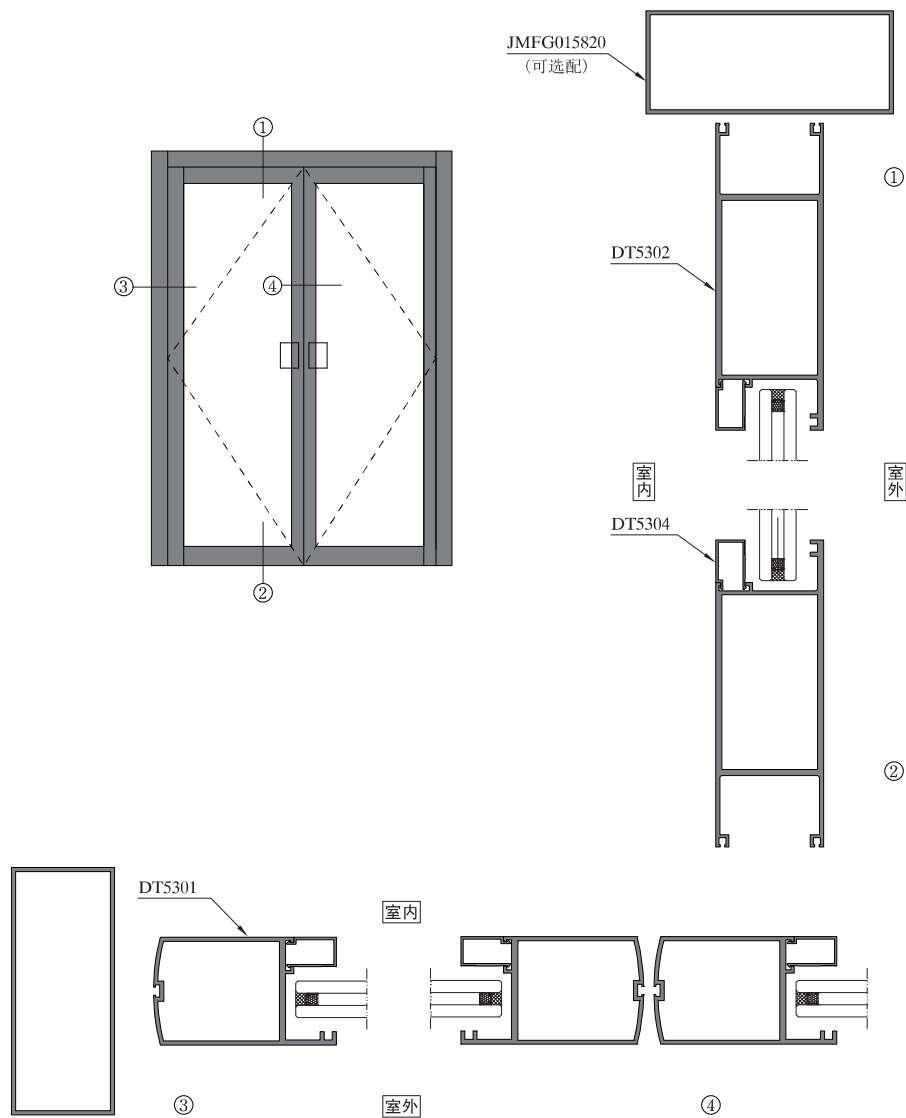

序号 S/N	型号理论重量 JMA Code & KG/M	型材图 Drawing	序号 S/N	型号理论重量 JMA Code & KG/M	型材图 Drawing	序号 S/N	型号理论重量 JMA Code & KG/M	型材图 Drawing
1	扇料 DT5301 1.765kg/m		10			19		
2	扇料 DT5302 3.079kg/m		11			20		
3	压线 DT5304 0.216kg/m		12			21		
4	JMFG015820 1.943kg/m		13			22		
5			14			23		
6			15			24		
7			16			25		
8			17			26		
9			18			27		

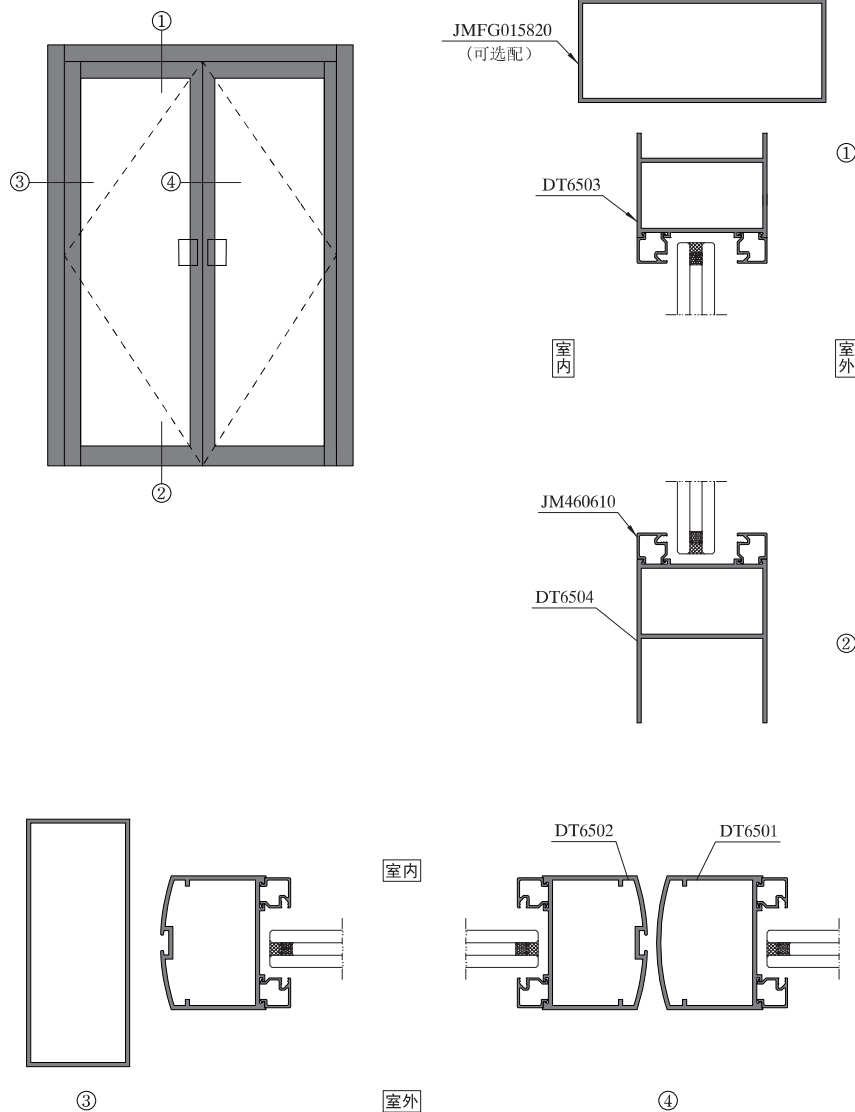

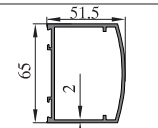
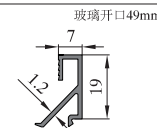
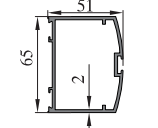
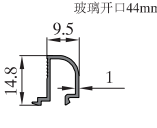
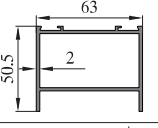
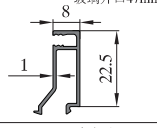
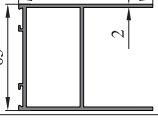
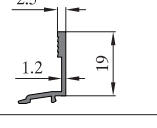
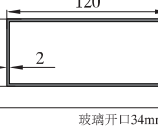
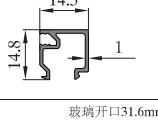
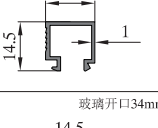
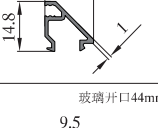
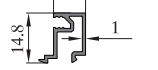
序号 S/N	型号理论重量 JMA Code & KG/M	型材图 Drawing	序号 S/N	型号理论重量 JMA Code & KG/M	型材图 Drawing	序号 S/N	型号理论重量 JMA Code & KG/M	型材图 Drawing
1	扇料 DT6501 1.353kg/m		10	压线 JM4606H12 0.181kg/m		19		
2	扇料 DT6502 1.409kg/m		11	压线 JM4606N10 0.119kg/m		20		
3	扇料 DT6503 1.322kg/m		12	压线 JM4606T 0.189kg/m		21		
4	扇料 DT6504 1.662kg/m		13	压线 JM4606Y 0.146kg/m		22		
5	JMFG015820 1.943kg/m		14			23		
6	压线 JM460610 0.158kg/m		15			24		
7	压线 JM4606B10 0.149kg/m		16			25		
8	压线 JM4606C10 0.127kg/m		17			26		
9	压线 JM4606E10 0.148kg/m		18			27		

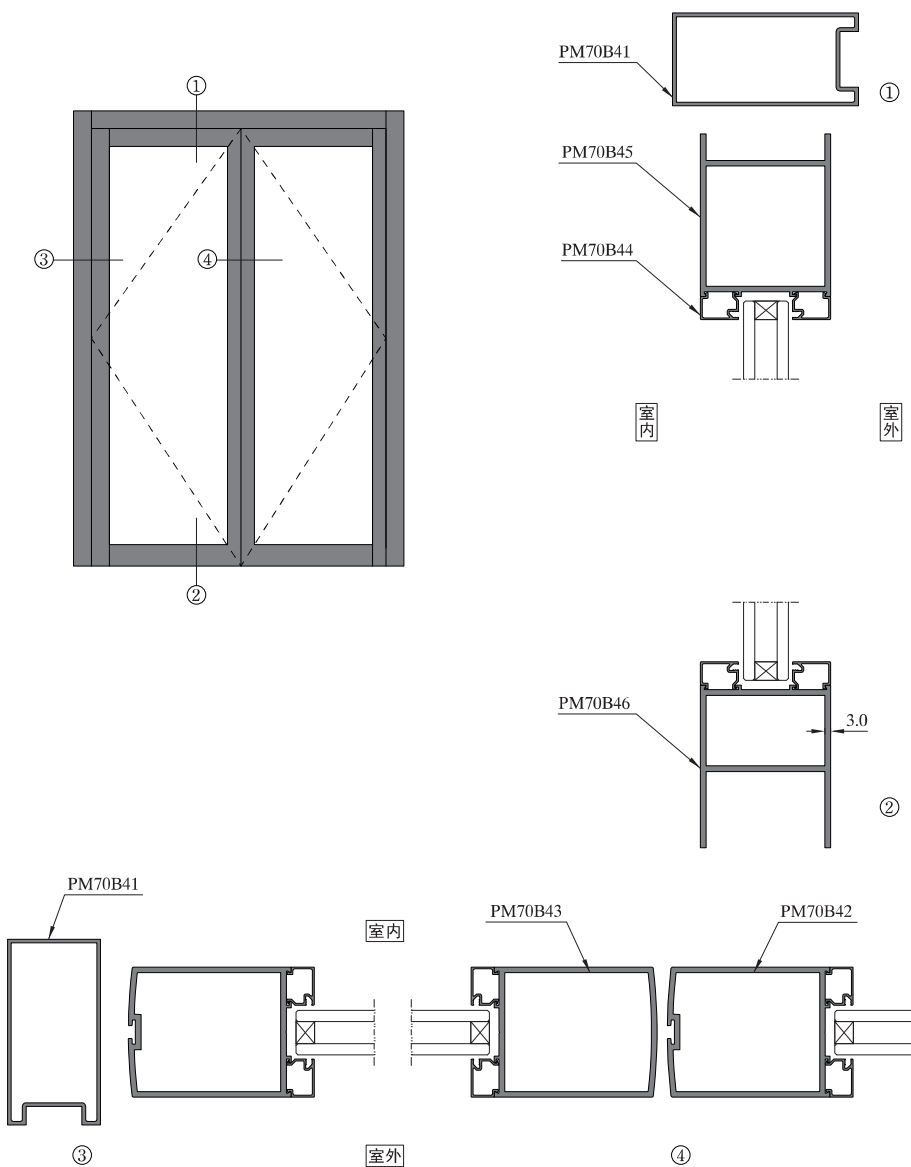

序号 S/N	型号理论重量 JMA Code & KG/M	型材图 Drawing	序号 S/N	型号理论重量 JMA Code & KG/M	型材图 Drawing	序号 S/N	型号理论重量 JMA Code & KG/M	型材图 Drawing
1	PM70B41 1.824kg/m		10			19		
2	PM70B41A 1.288kg/m		11			20		
3	PM70B42 2.753kg/m		12			21		
4	PM70B43 2.652kg/m		13			22		
5	PM70B44 0.176kg/m		14			23		
6	PM70B45 2.687kg/m		15			24		
7	PM70B46 2.687kg/m		16			25		
8			17			26		
9			18			27		

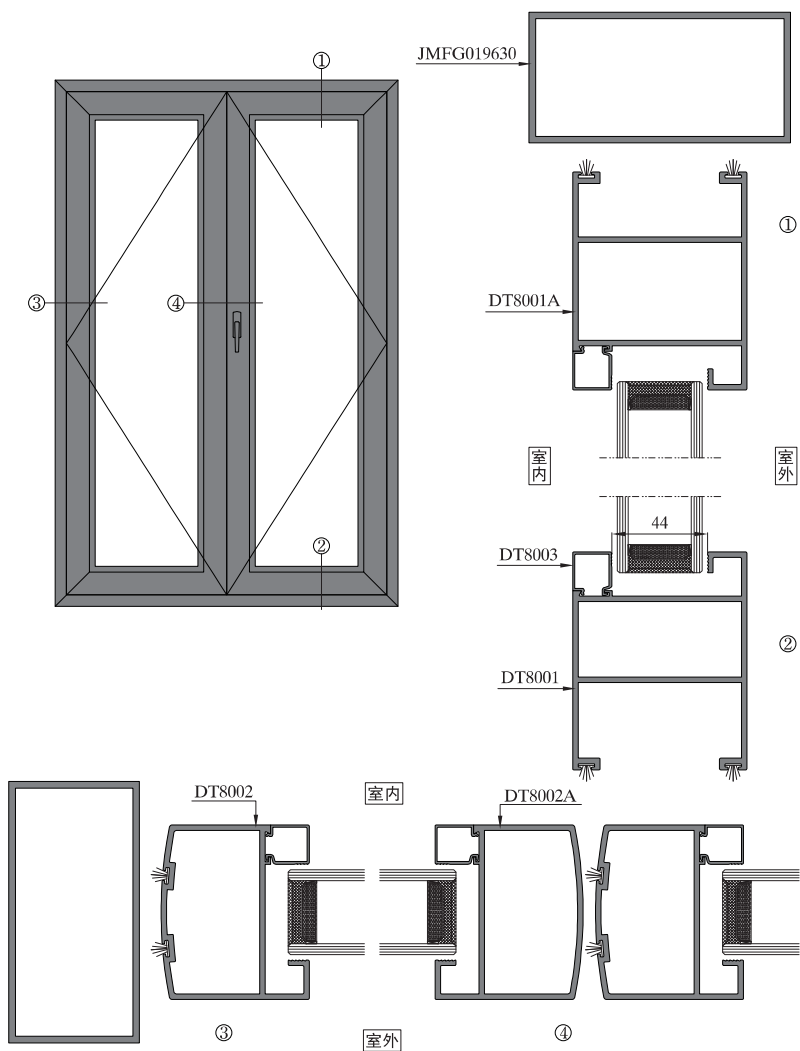

序号 S/N	型号理论重量 JMA Code & KG/M	型材图 Drawing	序号 S/N	型号理论重量 JMA Code & KG/M	型材图 Drawing	序号 S/N	型号理论重量 JMA Code & KG/M	型材图 Drawing
1	扇料 DT8001 2.813kg/m		10			19		
2	扇料 DT8001A 2.813kg/m		11			20		
3	扇料 DT8002 2.189kg/m		12			21		
4	扇料 DT8002A 2.087kg/m		13			22		
5	压线 DT8003 0.197kg/m		14			23		
6	方管 JMFG019630 3.055kg/m		15			24		
7			16			25		
8			17			26		
9			18			27		

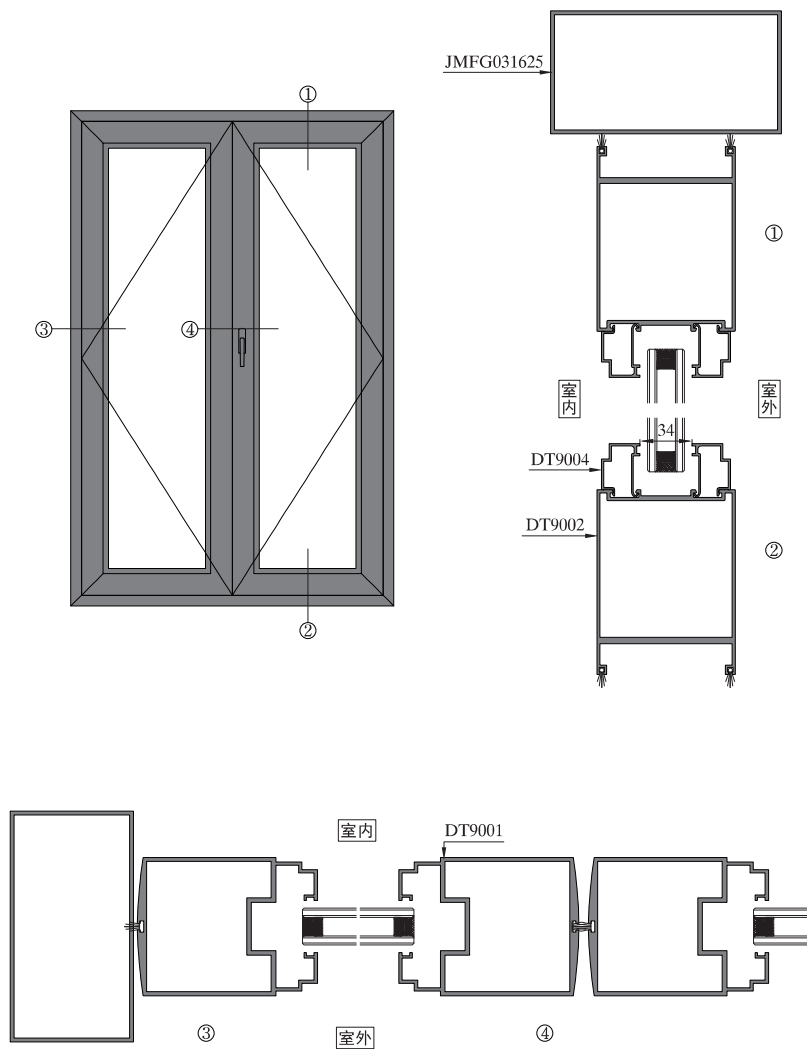

序号 S/N	型号理论重量 JMA Code & KG/M	型材图 Drawing	序号 S/N	型号理论重量 JMA Code & KG/M	型材图 Drawing	序号 S/N	型号理论重量 JMA Code & KG/M	型材图 Drawing
1	扇料 DT9001 4.162kg/m		10			19		
2	扇料 DT9002 3.228kg/m		11			20		
3	压线 DT9004 0.404kg/m		12			21		
4	方管 JMFG031625 3.293kg/m		13			22		
5			14			23		
6			15			24		
7			16			25		
8			17			26		
9			18			27		

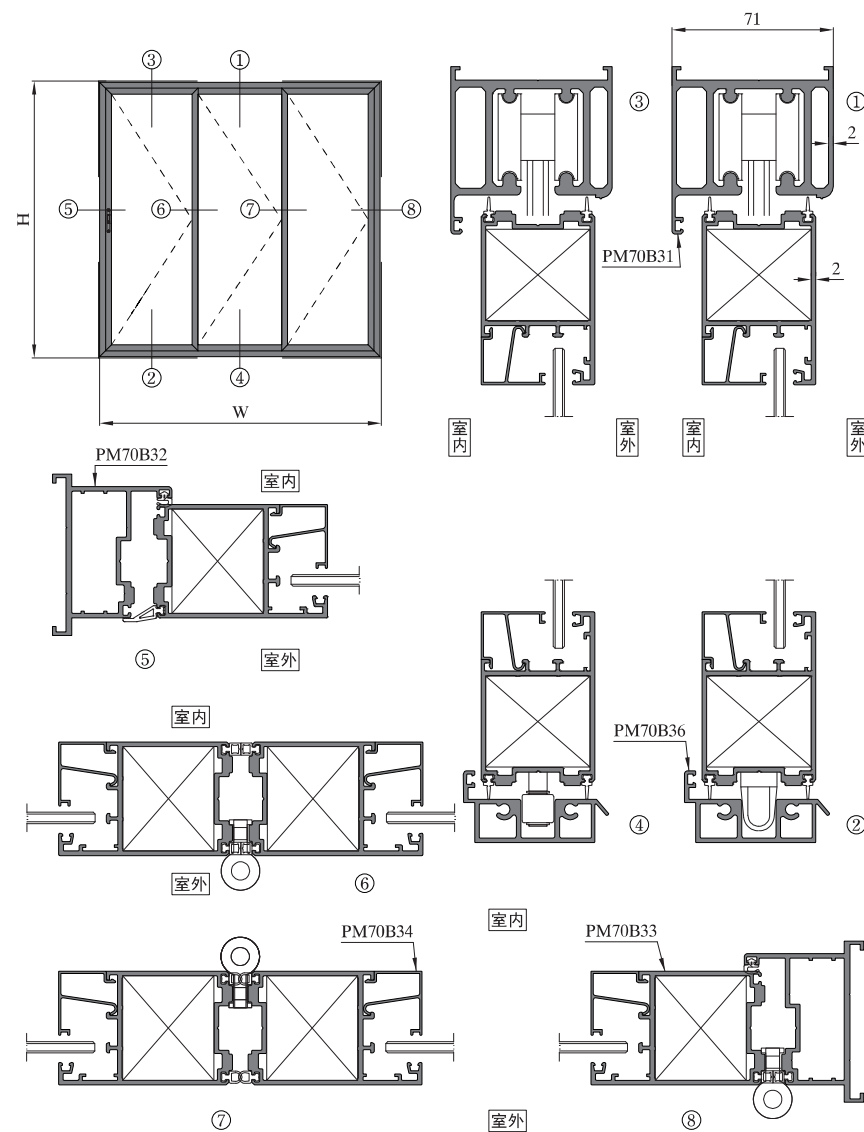
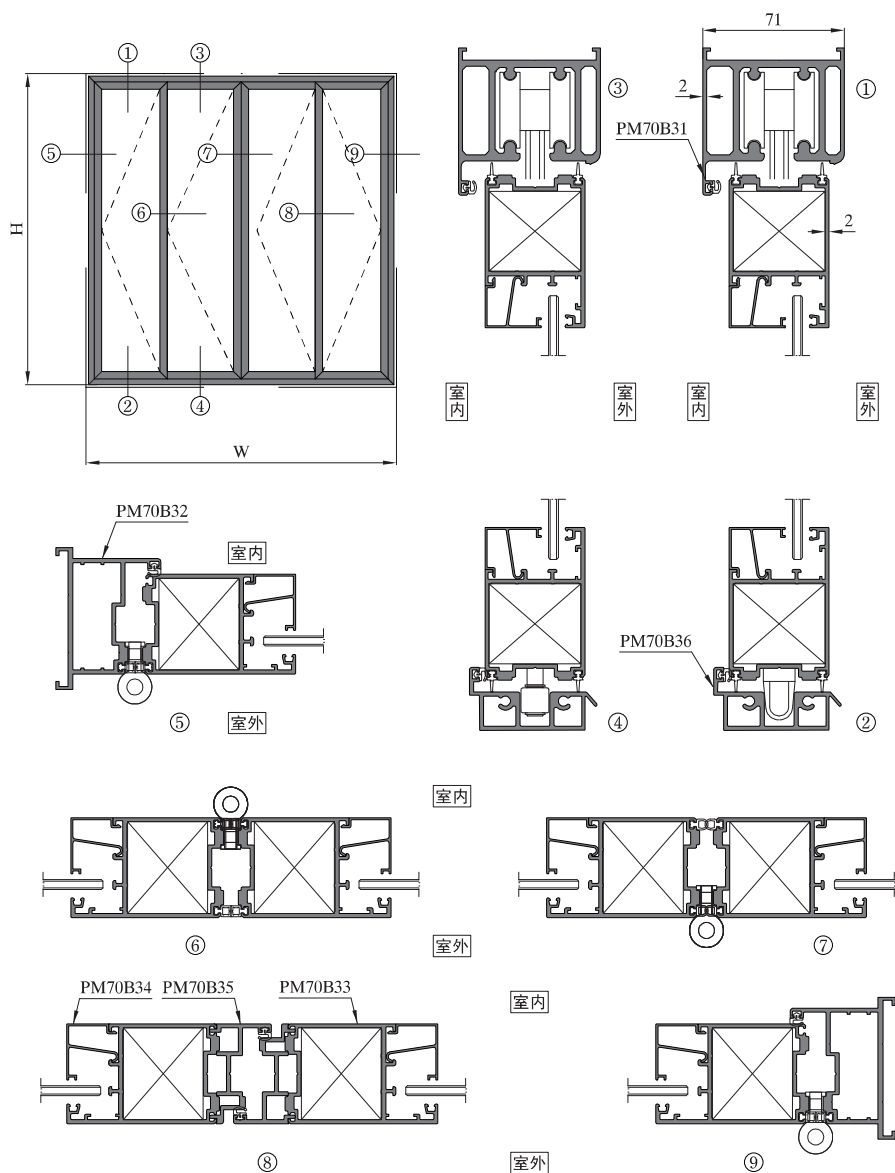

序号 S/N	型号理论重量 JMA Code & KG/M	型材图 Drawing	序号 S/N	型号理论重量 JMA Code & KG/M	型材图 Drawing	序号 S/N	型号理论重量 JMA Code & KG/M	型材图 Drawing
1	框料 PM70B31 3.185kg/m		10			19		
2	框料 PM70B32 1.455kg/m		11			20		
3	扇料 PM70B33 1.604kg/m		12			21		
4	扇压线 PM70B34 0.268kg/m		13			22		
5	收口 PM70B35 0.717kg/m		14			23		
6	框料 PM70B36 1.187kg/m		15			24		
7	角码 JMGR7535A 4.996kg/m		16			25		
8			17			26		
9			18			27		

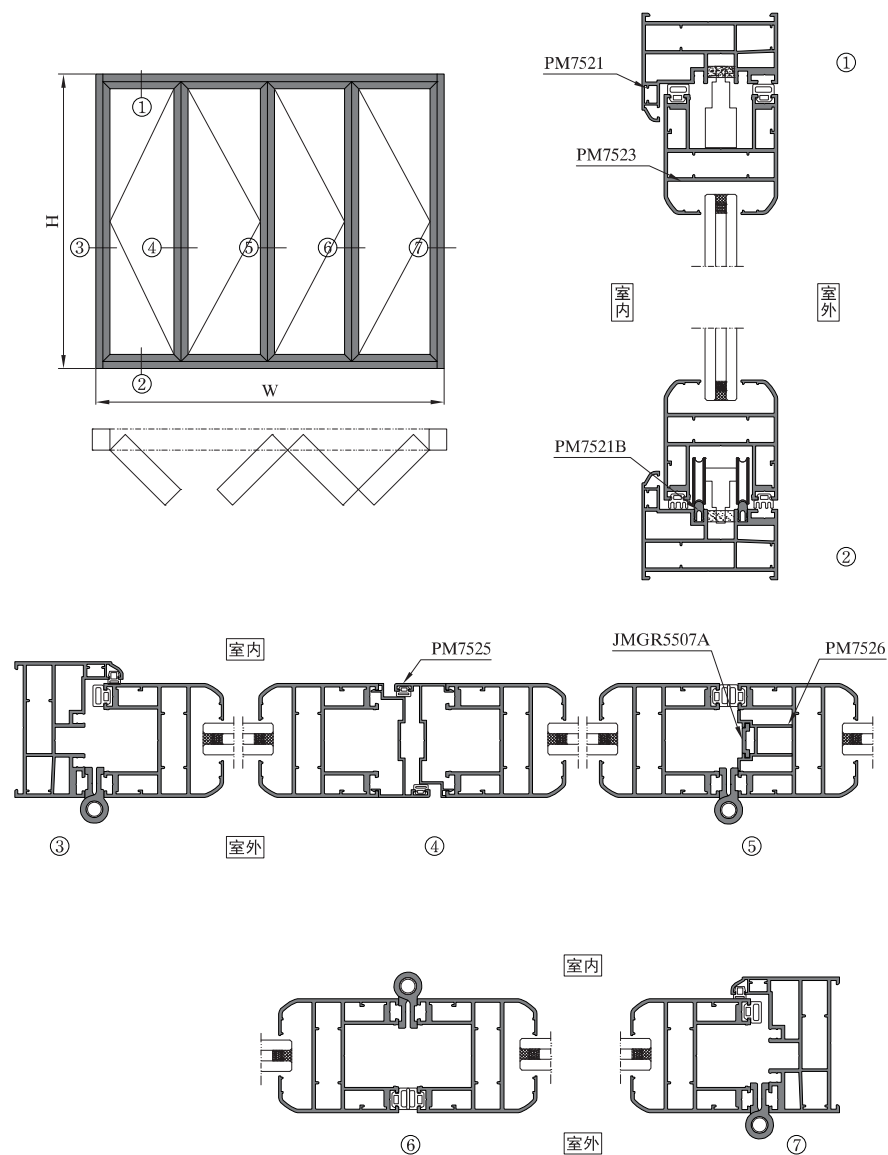

序号 S/N	型号理论重量 JMA Code & KG/M	型材图 Drawing	序号 S/N	型号理论重量 JMA Code & KG/M	型材图 Drawing	序号 S/N	型号理论重量 JMA Code & KG/M	型材图 Drawing
1	门框 PM7521 2.317kg/m		10			19		
2	门下轨 PM7521A 1.065kg/m		11			20		
3	轨道 PM7521B 0.107kg/m		12			21		
4	门扇 PM7523 2.272kg/m		13			22		
5	门收口 PM7525 0.522kg/m		14			23		
6	门收口 PM7525A 0.584kg/m		15			24		
7	锁槽 PM7526 0.414kg/m		16			25		
8	连杆 JMGR5507A 0.153kg/m		17			26		
9			18			27		

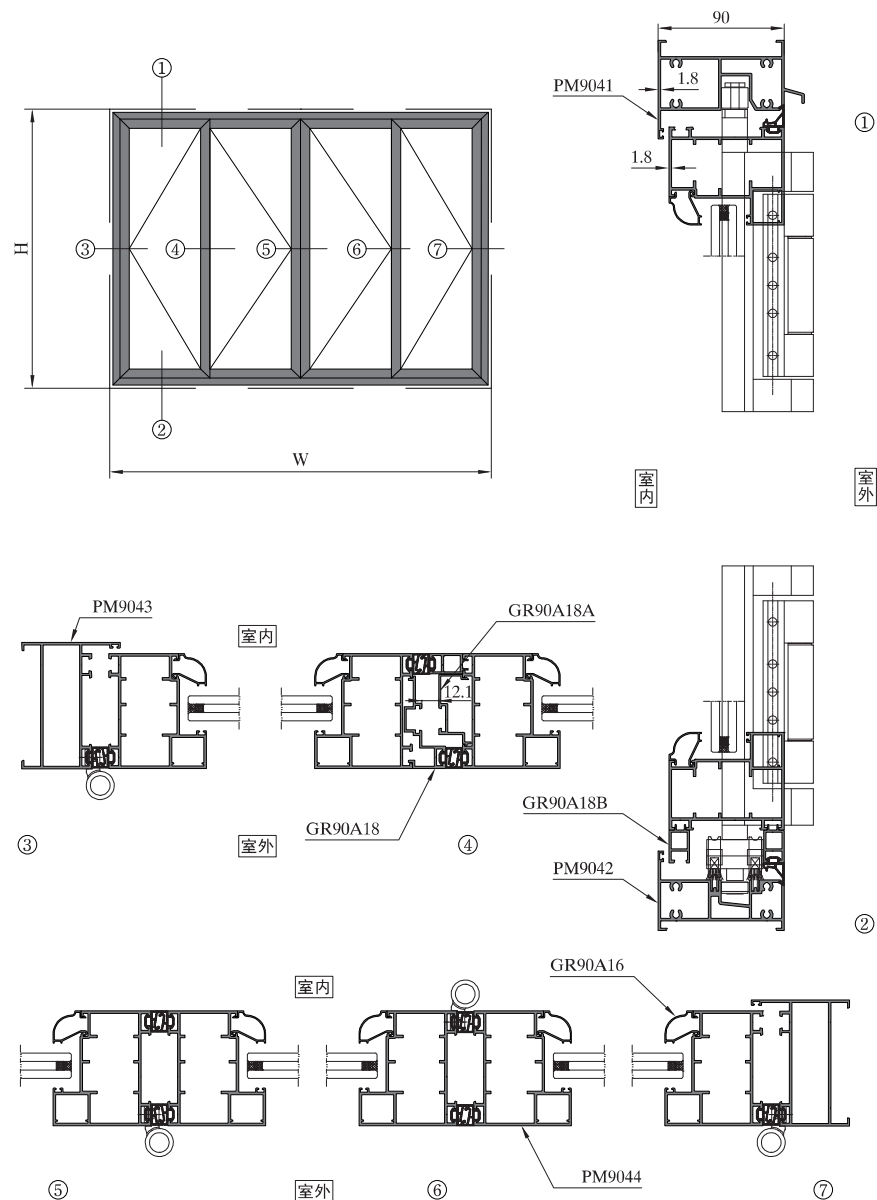

序号 S/N	型号理论重量 JMA Code & KG/M	型材图 Drawing	序号 S/N	型号理论重量 JMA Code & KG/M	型材图 Drawing	序号 S/N	型号理论重量 JMA Code & KG/M	型材图 Drawing
1	框料 PM9041 2.300kg/m		10			19		
2	框料 PM9042 2.188kg/m		11			20		
3	框料 PM9043 1.761kg/m		12			21		
4	扇料 PM9044 2.062kg/m		13			22		
5	扇压线 GR90A16 0.201kg/m		14			23		
6	收口 GR90A18 0.665kg/m		15			24		
7	收口 GR90A18A 0.438kg/m		16			25		
8	GR90A18B 0.345kg/m		17			26		
9	GR90A18C 0.238kg/m		18			27		

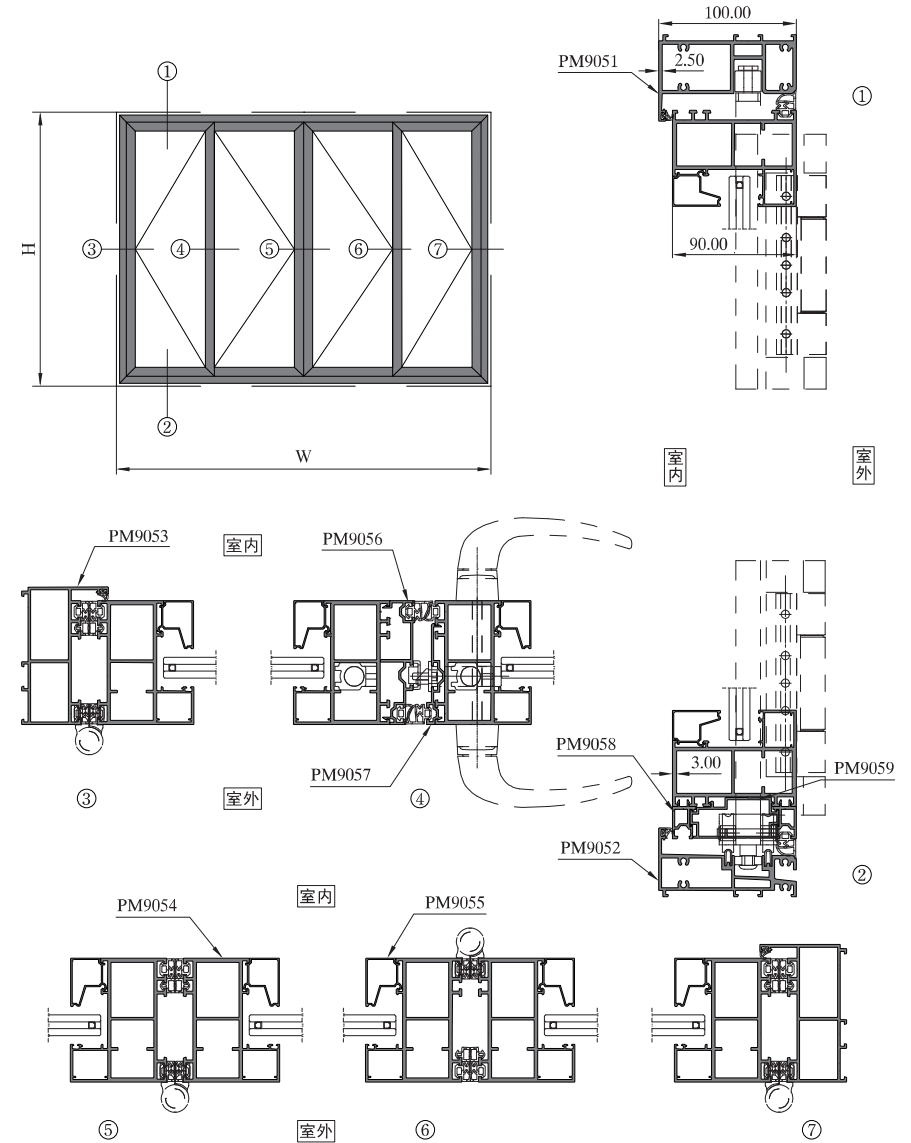

序号 S/N	型号理论重量 JMA Code & KG/M	型材图 Drawing	序号 S/N	型号理论重量 JMA Code & KG/M	型材图 Drawing	序号 S/N	型号理论重量 JMA Code & KG/M	型材图 Drawing
1	框料 PM9051 2.979kg/m		10	角码 GR90A38 7.404kg/m		19		
2	框料 PM9052 2.514kg/m		11			20		
3	框料 PM9053 2.249kg/m		12			21		
4	扇料 PM9054 2.879kg/m		13			22		
5	扇压线 PM9055 0.345kg/m		14			23		
6	PM9056 0.923kg/m		15			24		
7	PM9057 0.536kg/m		16			25		
8	PM9058 0.408kg/m		17			26		
9	PM9059 0.891kg/m		18			27		

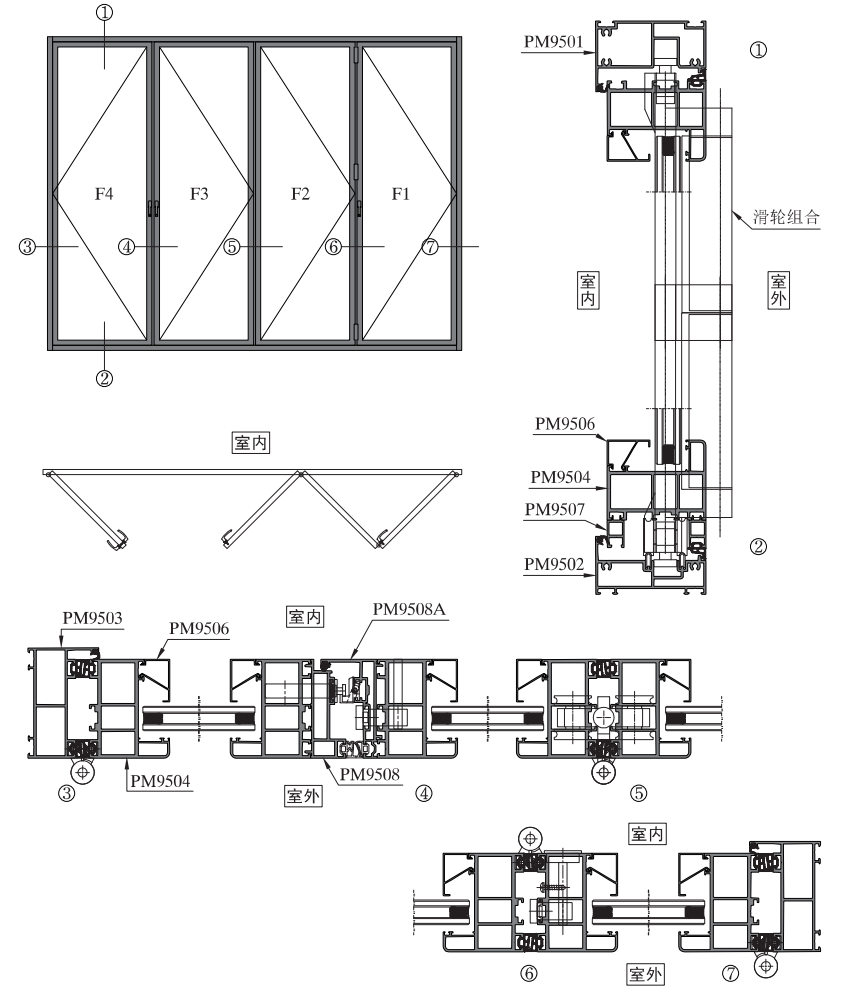

序号 S/N	型号理论重量 JMA Code & KG/M	型材图 Drawing	序号 S/N	型号理论重量 JMA Code & KG/M	型材图 Drawing	序号 S/N	型号理论重量 JMA Code & KG/M	型材图 Drawing
1	上轨 PM9501 2.388kg/m		10	双扇对开拼料 PM9508C 2.070kg/m		19		
2	下轨 PM9502 2.197kg/m		11	扇角码 JMGR5217 4.264kg/m		20		
3	边框 PM9503 2.077kg/m		12			21		
4	扇料 PM9504 3.076kg/m		13			22		
5	压线 PM9506 0.330kg/m		14			23		
6	扇底部拼料 PM9507 0.378kg/m		15			24		
7	对开主动扇拼料 PM9508 1.500kg/m		16			25		
8	对开被动扇拼料 PM9508A 1.583kg/m		17			26		
9	单边开启扇拼料 PM9508B 1.447kg/m		18			27		

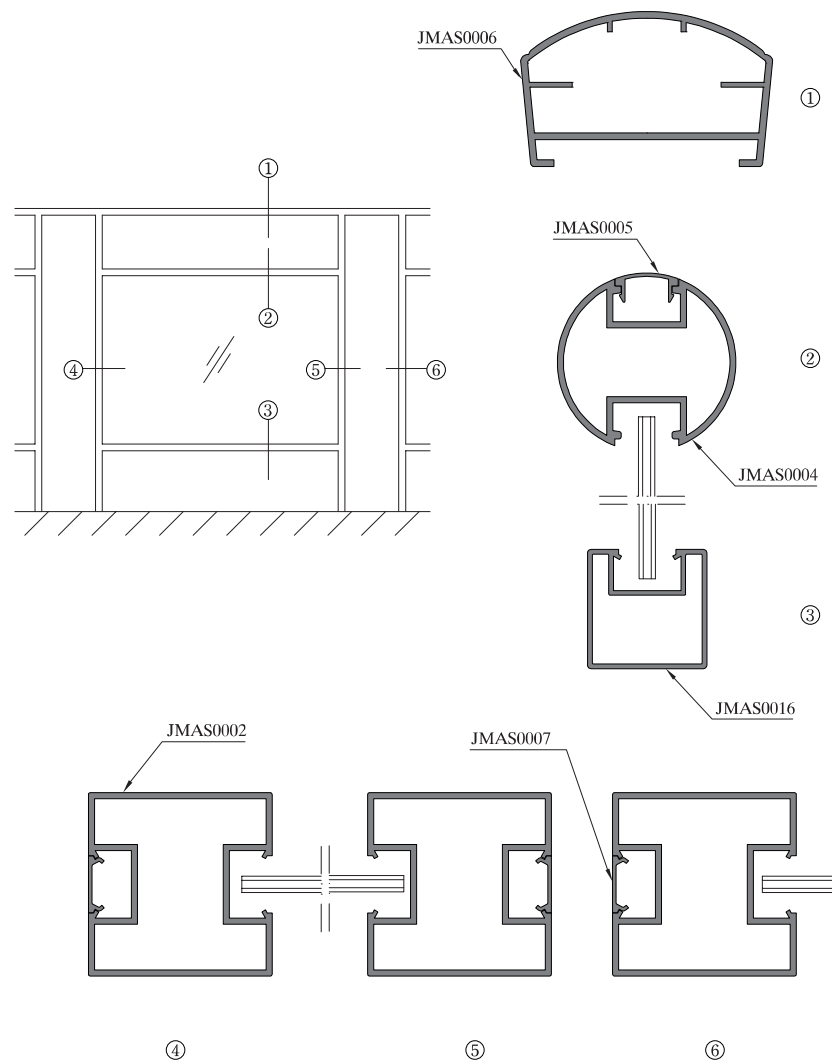

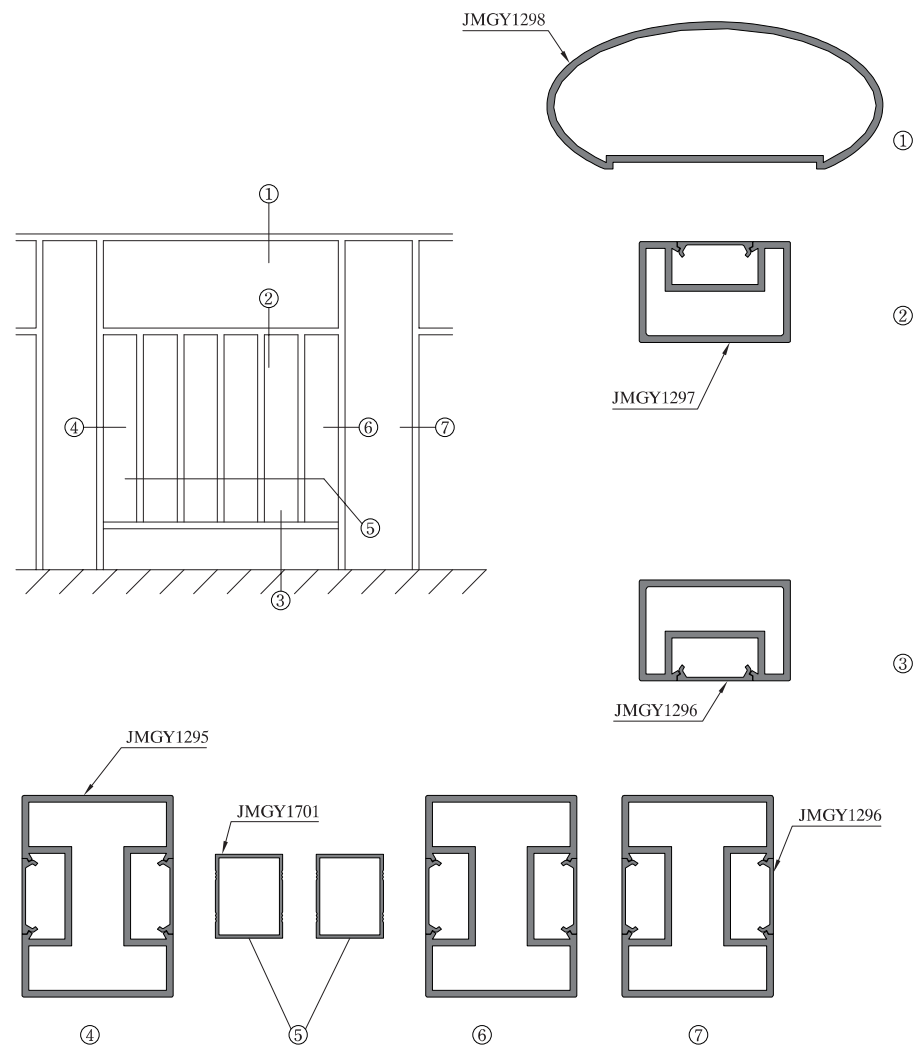
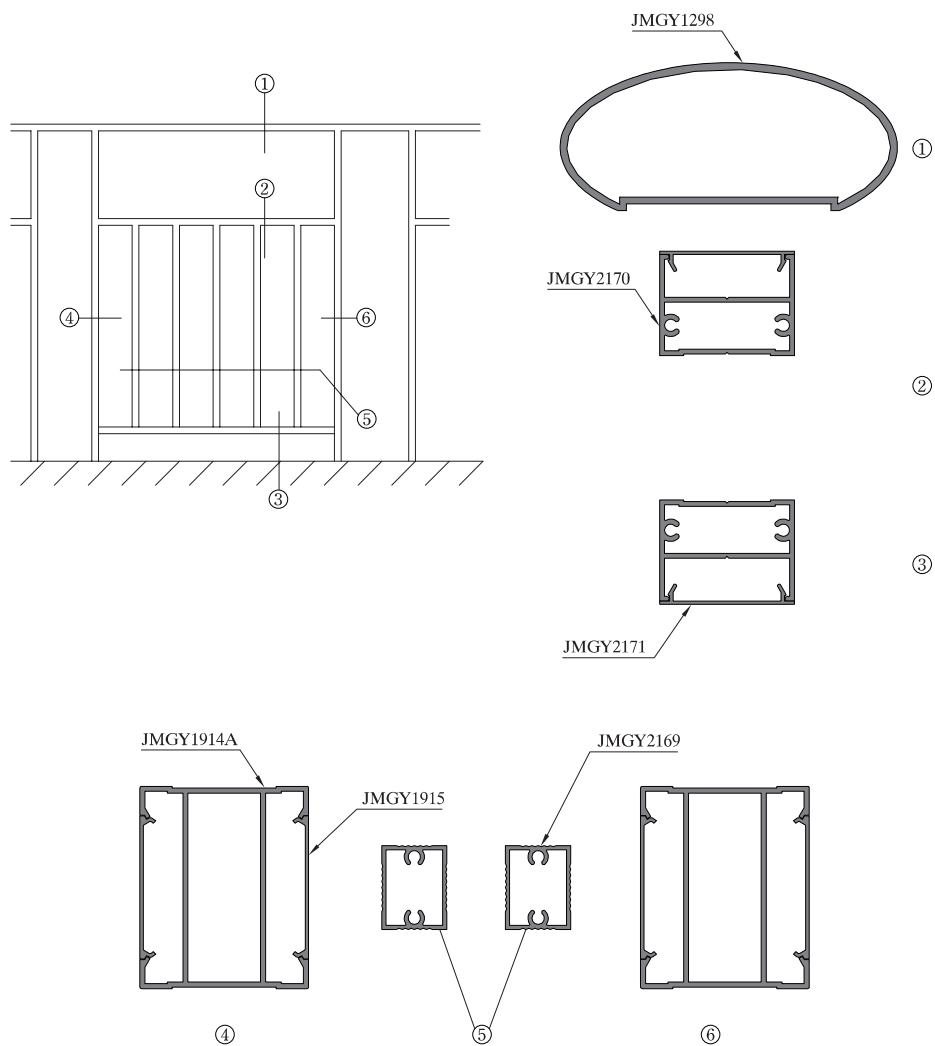

序号 S/N	型号理论重量 JMA Code & KG/M	型材图 Drawing	序号 S/N	型号理论重量 JMA Code & KG/M	型材图 Drawing	序号 S/N	型号理论重量 JMA Code & KG/M	型材图 Drawing
1	JMAS0001 1.373kg/m		10	JMAS0005 0.106kg/m		19	JMGY1493A 1.066kg/m	
2	JMAS0002 1.429kg/m		11	JMAS0006 1.405kg/m		20	JMGY1494 0.592kg/m	
3	JMAS0002A 1.089kg/m		12	JMAS0007 0.077kg/m		21	JMGY1495 0.100kg/m	
4	JMAS0002B 1.035kg/m		13	JMAS0016 0.680kg/m		22	JMGY1496 0.328kg/m	
5	JMAS0002C 1.124kg/m		14	JMGY1490 0.538kg/m		23	JMGY1496A 0.403kg/m	
6	JMAS0002D 1.147kg/m		15	JMGY1490A 0.715kg/m		24	JMGY1914 1.180kg/m	
7	JMAS0003 1.447kg/m		16	JMGY1491 0.108kg/m		25	JMGY1914A 1.093kg/m	
8	JMAS0003A 1.358kg/m		17	JMGY1492 0.437kg/m		26	JMGY1914C 1.548kg/m	
9	JMAS0004 1.166kg/m		18	JMGY1493 0.785kg/m		27	JMGY1915 0.151kg/m	

序号 S/N	型号理论重量 JMA Code & KG/M	型材图 Drawing	序号 S/N	型号理论重量 JMA Code & KG/M	型材图 Drawing	序号 S/N	型号理论重量 JMA Code & KG/M	型材图 Drawing
1	JMGY1913 0.598kg/m		10	JMGY1297 1.008kg/m		19		
2	JMGY2169 0.342kg/m		11	JMGY1701 0.294kg/m		20		
3	JMGY2170 0.648kg/m		12			21		
4	JMGY2171 0.150kg/m		13			22		
5	JM6435 0.126kg/m		14			23		
6	JMGY1298 1.395kg/m		15			24		
7	JMGY1298A 1.661kg/m		16			25		
8	JMGY1295 1.531kg/m		17			26		
9	JMGY1296 0.093kg/m		18			27		

图中所示型材截面、装配、编号、尺寸及重量仅供参考。如有疑问，请向本公司查询。
Information above just for your reference. Please contact us if you have any questions, Thank you!

图中所示型材截面、装配、编号、尺寸及重量仅供参考。如有疑问，请向本公司查询。
Information above just for your reference. Please contact us if you have any questions, Thank you!

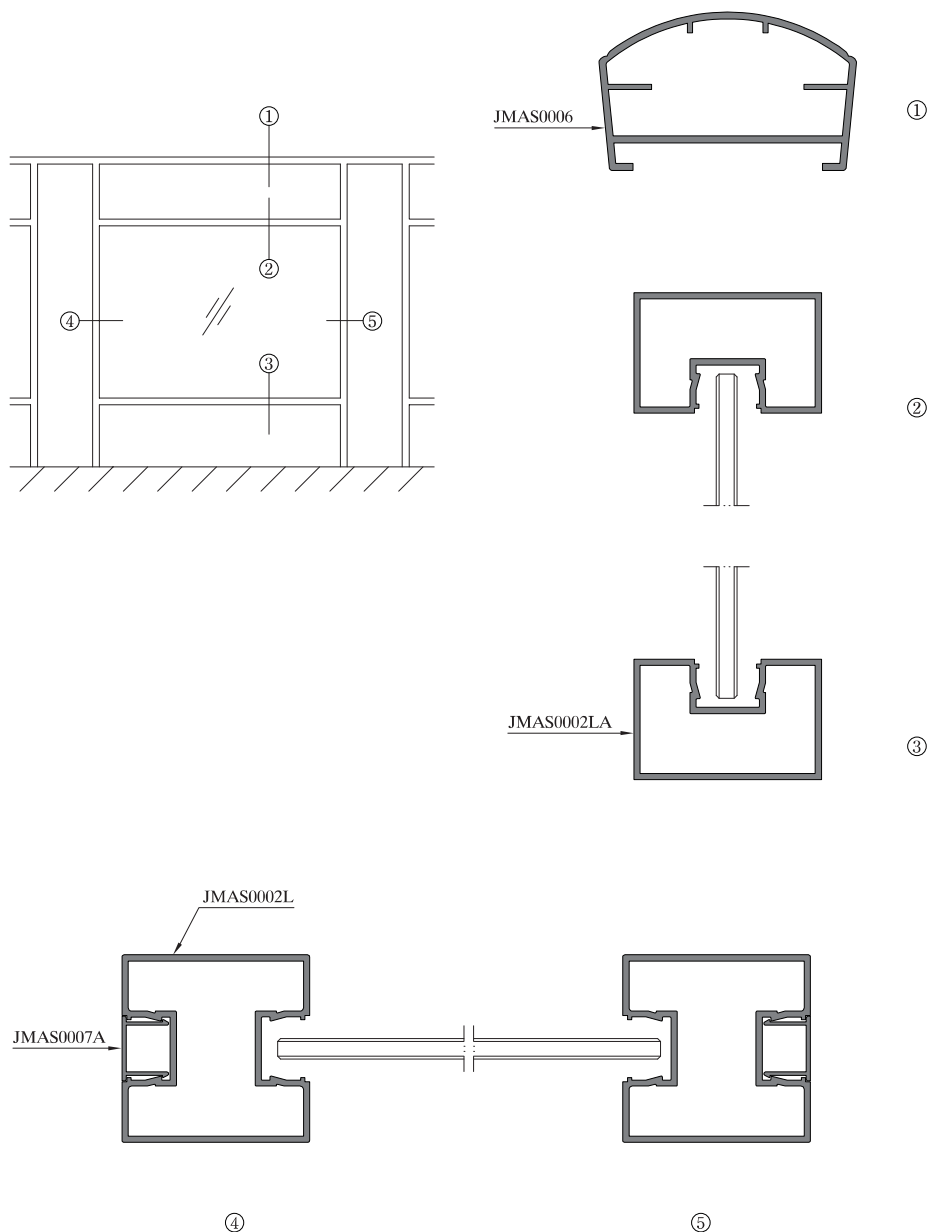

序号 S/N	型号理论重量 JMA Code & KG/M	型材图 Drawing	序号 S/N	型号理论重量 JMA Code & KG/M	型材图 Drawing	序号 S/N	型号理论重量 JMA Code & KG/M	型材图 Drawing
1	JMAS0001A 1.234kg/m		10	JMAS0001L 1.417kg/m		19	JMAS0004 1.166kg/m	
2	JMAS0001B 1.436kg/m		11	JMAS0002L 1.419kg/m		20	JMAS0005 0.106kg/m	
3	JMAS0001C 1.211kg/m		12	JMAS0002LA 1.067kg/m		21	JMAS0006A 1.590kg/m	
4	JMAS0001E 1.139kg/m		13	JMAS0002LG 0.759kg/m		22	JMAS0006C 1.227kg/m	
5	JMAS0001F 1.164kg/m		14	JMAS0002S 1.088kg/m		23	JMAS0006D 1.034kg/m	
6	JMAS0001G 1.360kg/m		15	JMAS0002T 1.251kg/m		24	JMAS0007A 0.140kg/m	
7	JMAS0001H 0.787kg/m		16	JMAS0003B 1.434kg/m		25		
8	JMAS0001J 1.360kg/m		17	JMAS0003B14 1.142kg/m		26		
9	JMAS0001K 0.943kg/m		18	JMAS0003C 1.605kg/m		27		

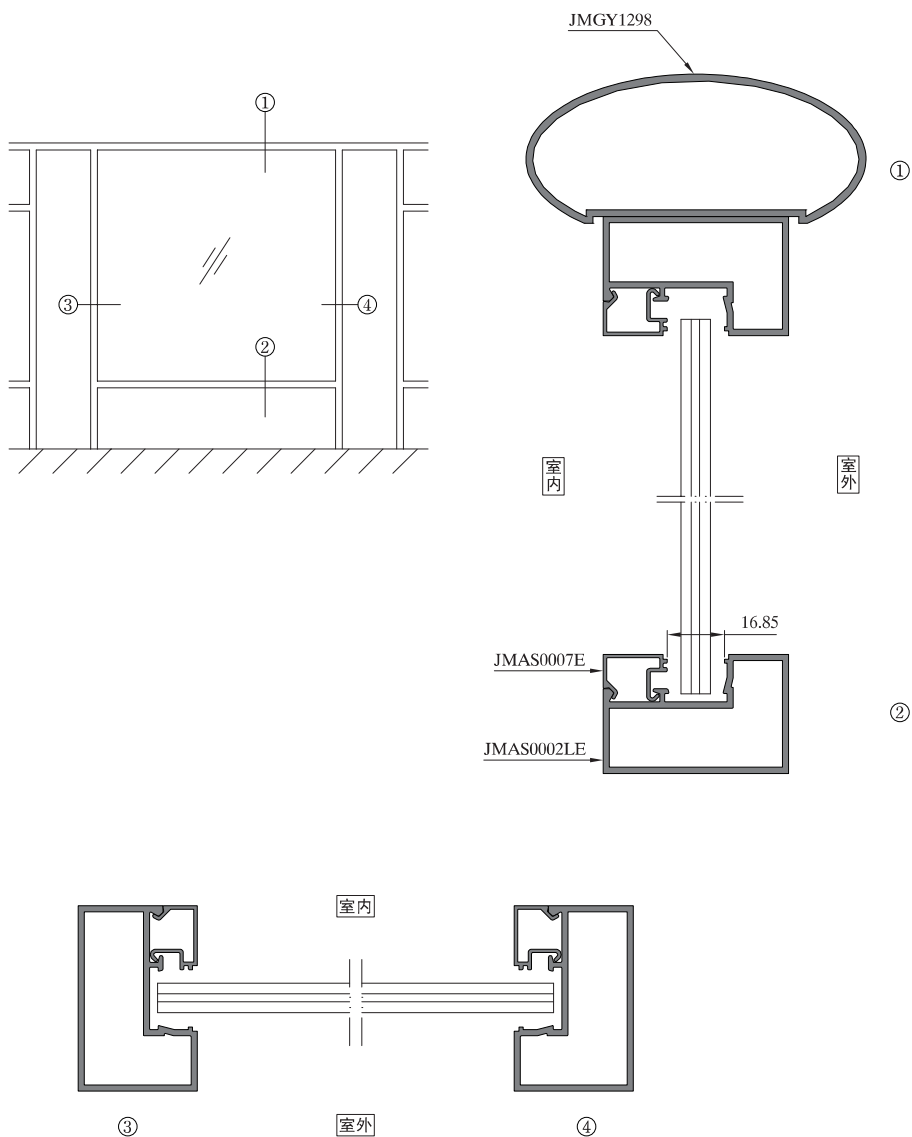

序号 S/N	型号理论重量 JMA Code & KG/M	型材图 Drawing	序号 S/N	型号理论重量 JMA Code & KG/M	型材图 Drawing	序号 S/N	型号理论重量 JMA Code & KG/M	型材图 Drawing
1	JMGY1298 1.395kg/m		10			19		
2	JMGY6798 2.132kg/m		11			20		
3	JMGY6799 0.280kg/m		12			21		
4	JMAS0002L 1.419kg/m		13			22		
5	JMAS0002LA 1.067kg/m		14			23		
6	JMAS0002LE 0.968kg/m		15			24		
7	JMAS0003B 1.434kg/m		16			25		
8	JMAS0007A 0.140kg/m		17			26		
9	JMAS0007E 0.160kg/m		18			27		

图中所示型材截面、装配、编号、尺寸及重量仅供参考。如有疑问，请向本公司查询。
Information above just for your reference. Please contact us if you have any questions, Thank you!

图中所示型材截面、装配、编号、尺寸及重量仅供参考。如有疑问，请向本公司查询。
Information above just for your reference. Please contact us if you have any questions, Thank you!

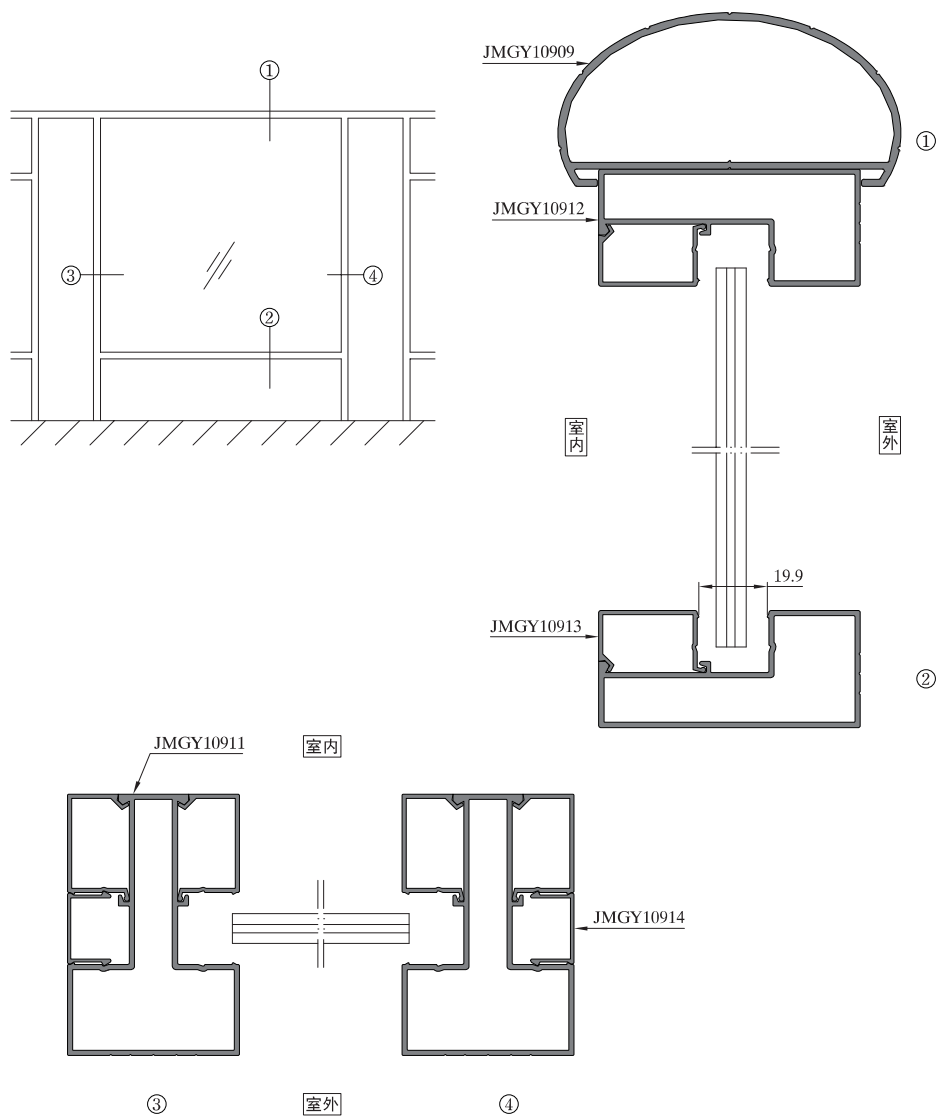

序号 S/N	型号理论重量 JMA Code & KG/M	型材图 Drawing	序号 S/N	型号理论重量 JMA Code & KG/M	型材图 Drawing	序号 S/N	型号理论重量 JMA Code & KG/M	型材图 Drawing
1	JMGY10909 1.544kg/m		10			19		
2	JMGY10910 1.538kg/m		11			20		
3	JMGY10911 1.166kg/m		12			21		
4	JMGY10912 0.982kg/m		13			22		
5	JMGY10913 0.231kg/m		14			23		
6	JMGY10914 0.130kg/m		15			24		
7			16			25		
8			17			26		
9			18			27		

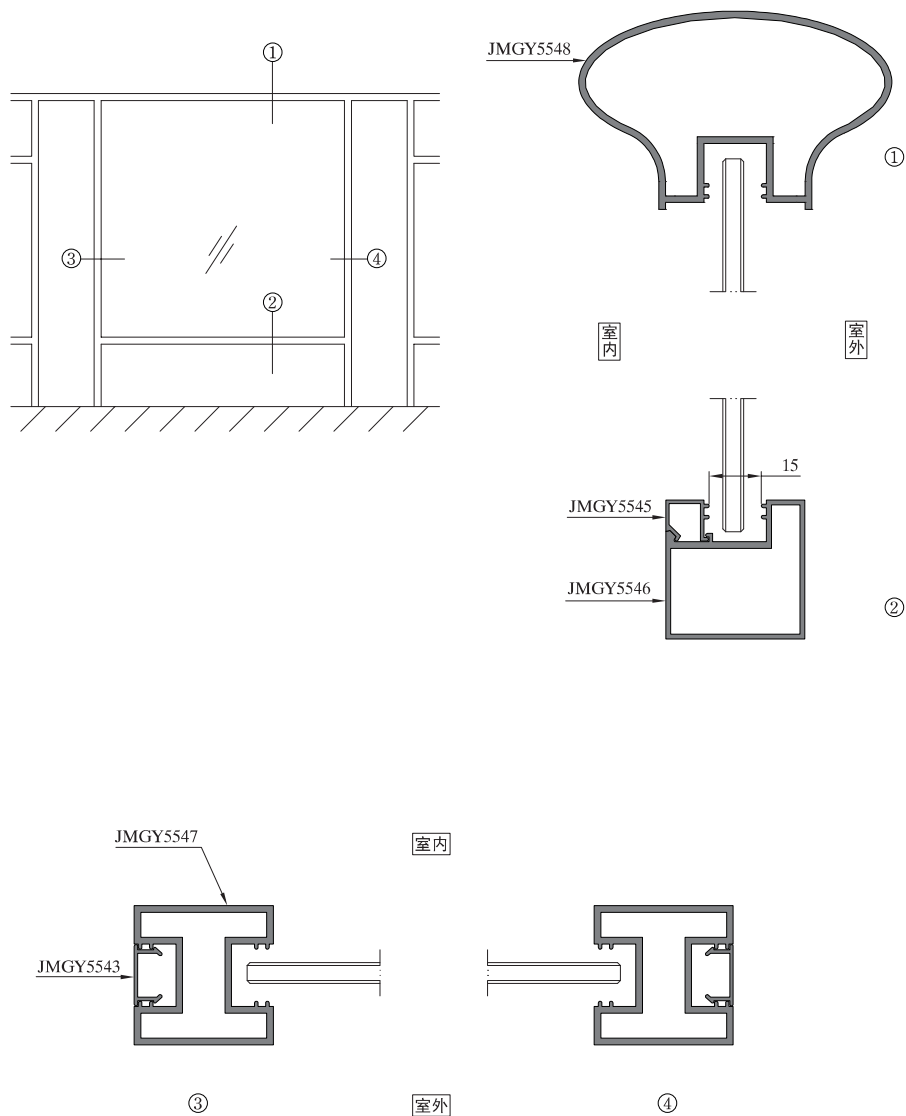

序号 S/N	型号理论重量 JMA Code & KG/M	型材图 Drawing	序号 S/N	型号理论重量 JMA Code & KG/M	型材图 Drawing	序号 S/N	型号理论重量 JMA Code & KG/M	型材图 Drawing
1	JMGY5543 0.096kg/m		10			19		
2	JMGY5544 1.481kg/m		11			20		
3	JMGY5545 0.113kg/m		12			21		
4	JMGY5546 0.715kg/m	压线配JMGY5545 玻璃开口为15mm 	13			22		
5	JMGY5547 1.147kg/m		14			23		
6	JMGY5548 1.526kg/m		15			24		
7			16			25		
8			17			26		
9			18			27		

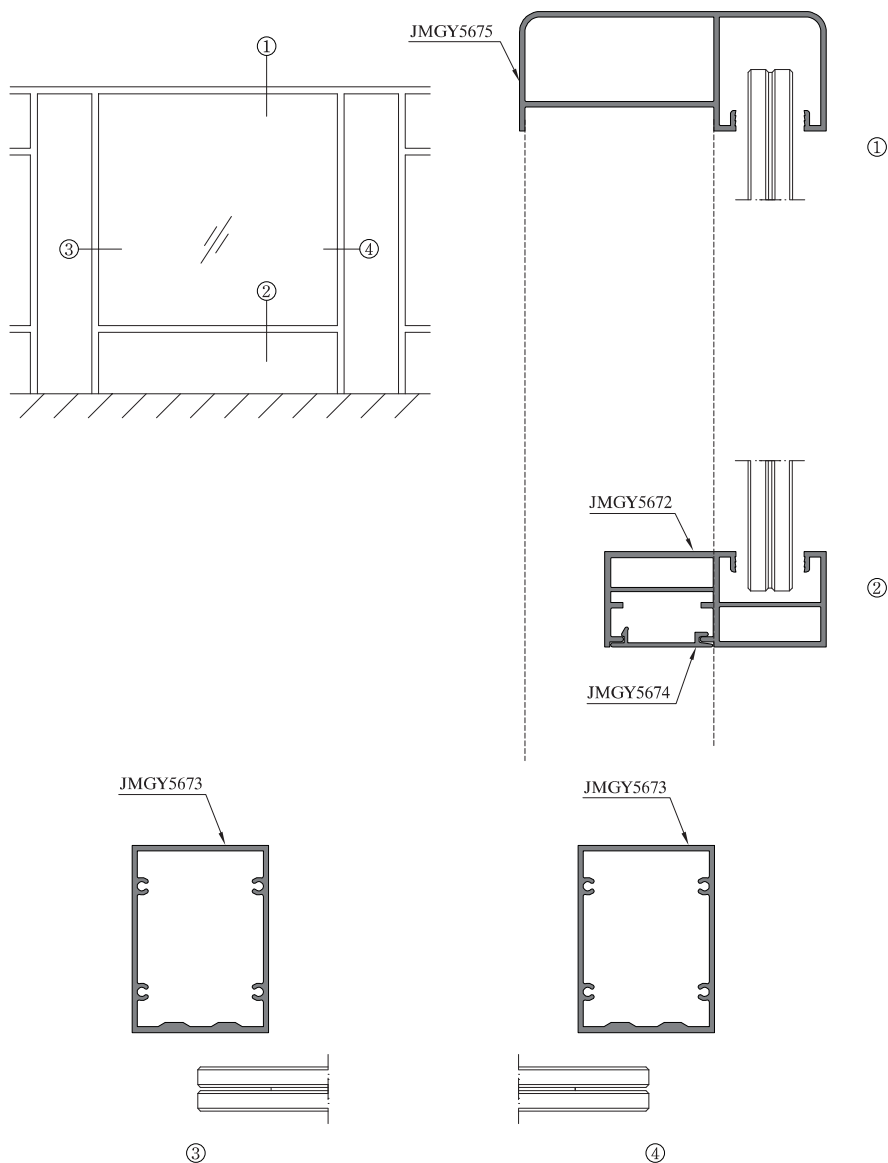

序号 S/N	型号理论重量 JMA Code & KG/M	型材图 Drawing	序号 S/N	型号理论重量 JMA Code & KG/M	型材图 Drawing	序号 S/N	型号理论重量 JMA Code & KG/M	型材图 Drawing
1	JMGY5672 1.079kg/m		10			19		
2	JMGY5673 1.000kg/m		11			20		
3	JMGY5674 0.139kg/m		12			21		
4	JMGY5675 1.212kg/m		13			22		
5			14			23		
6			15			24		
7			16			25		
8			17			26		
9			18			27		

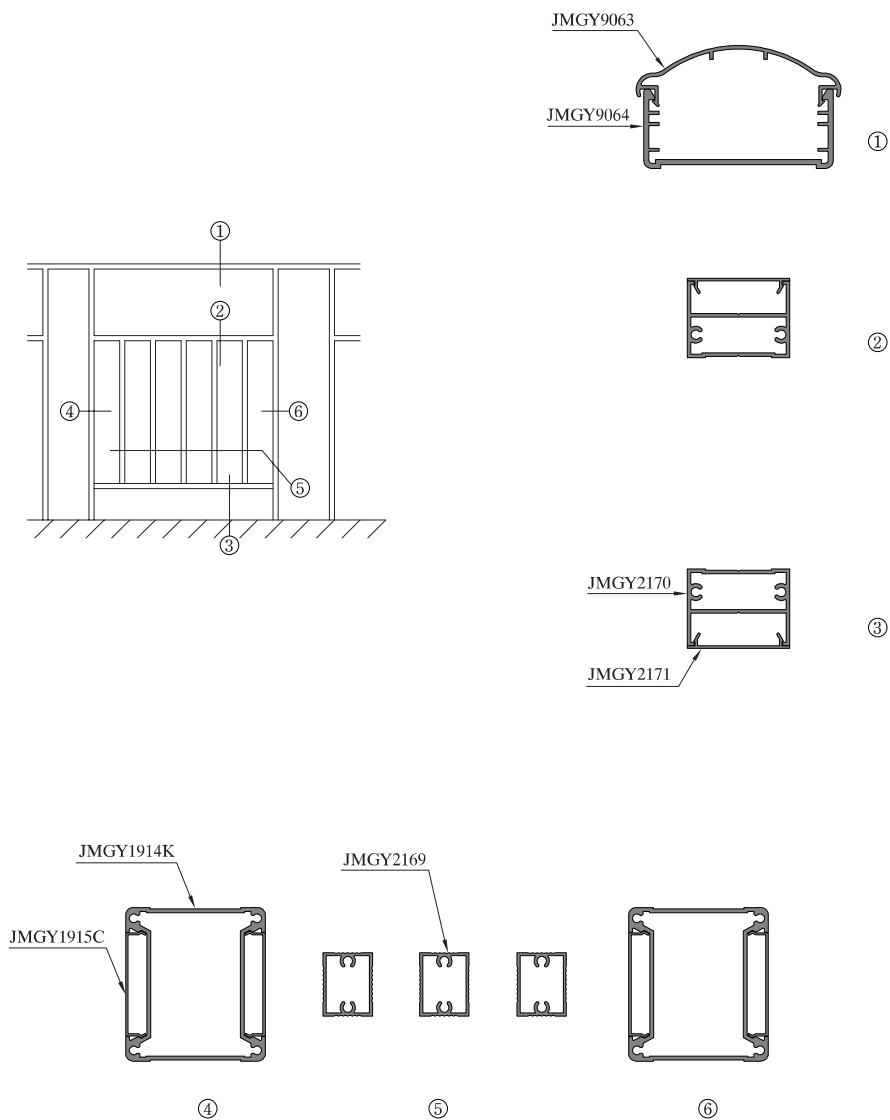

序号 S/N	型号理论重量 JMA Code & KG/M	型材图 Drawing	序号 S/N	型号理论重量 JMA Code & KG/M	型材图 Drawing	序号 S/N	型号理论重量 JMA Code & KG/M	型材图 Drawing
1	JMGY9063 0.527kg/m		10			19		
2	JMGY9064 0.900kg/m		11			20		
3	JMGY1914K 1.259kg/m		12			21		
4	JMGY1915C 0.152kg/m		13			22		
5	JMGY2169 0.342kg/m		14			23		
6	JMGY2170 0.648kg/m		15			24		
7	JMGY2171 0.150kg/m		16			25		
8			17			26		
9			18			27		

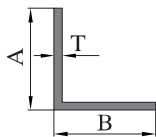

型材编号 Sections NO.	A (mm)	B (mm)	T (mm)	重量 (kg/m)
JM1044	12	8	1.2 (有槽位)	0.065
JMA0456	15	7	1.5	0.090
JMA0583	15	5	2.0	0.106
JM1031	20	12	2.0	0.176
JM1038	20	15	3.0	0.281
JM1045A	20	10	1.3	0.109
JM1055	20	12	1.4	0.125
JMA0427	20	14.7	3.0	0.279
JM1039	22	10	2.0	0.176
JM1033	25	20	2.0	0.252
JM1042	25	15	2.0	0.222
JM1047	25	11.2	2.0	0.200
JM1073	25	12	1.5	0.156
JMA0005	25	19	1.3	0.162
JM1053	26	23	3.0	0.404
JMA043820	26	18	2.0	0.246
JM1003	30	20	2.0/2.6/3.0	0.281/0.361/0.413
JM1040	30	11	2.0	0.228
JM1040A	30	11	3.0	0.334
JM1101	30	12.7	2.5	0.294
JMA0451	30	25	4.0	0.597
JM1050	32	12	1.2	0.150
JM1076	32	75	6.5 (带槽位)	1.901
JMA0435	32	17	1.5	0.209
JM1023	34	26	3.0	0.500
JM1035	34	9	2.0	0.240
JM1089	34	19	3.0	0.440
JMA0535	34	20	2.5	0.377
JM1087	35	13	2.5	0.333

型材编号 Sections NO.	A (mm)	B (mm)	T (mm)	重量 (kg/m)
JMA0099A	35	20	2.0	0.310
JMA020240	35	30	4.0	0.714
JMA0437	35	27	3.0	0.518
JMA0567	35	27	3.0	0.518
JMA0503	37	20	2.0	0.322
JM1009	38	19	3.0/3.5/4.7	0.474/0.549/0.719
JM1024	38	18	3.0 (带圆角)	0.465
JM1028	38	25	3.0/3.2/4.0	0.527/0.561/0.691
JM1036	38	21	5.0	0.791
JMGY0759	38	17.5	5.0 (带VG槽)	0.739
JMA0563	38	18	4.0	0.609
JMA0007	38.1	15	1.5	0.227
JM1081	40	24	4.0	0.702
JM1085	40	20	2.0	0.339
JMA0013	40	30	2.0	0.400
JMA001340	40	30	4.0	0.772
JMA0520	40	25	4.8	0.846
JMA0525	40	26	3.0	0.553
JMA0501	41	30	3.0	0.597
JMGY0758	41.7	34	10.0 (带VG槽)	1.922
JMA0436	42	27	3.0	0.580
JMA0508	43	20	2.0	0.357
JMA0522	43	40	3.0	0.702
JM1062	45	12	2.0	0.322
JMA0418	45	25	4.0	0.772
JMA0419	46	30	2.0	0.433
JMA0556	46	15	3.0	0.510
JMA0477	47	20	1.2	0.231
JM1061	47.5	25	3.0	0.610
JM1030	50	30	2.8/3.0/4.0	0.633/0.676/0.890
JM1088	50	35	4.0	0.948
JM1092	50	32	5.0	1.126

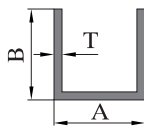

型材编号 Sections NO.	A (mm)	B (mm)	T (mm)	重量 (kg/m)
JM2036	7	15	1.0 (带圆角)	0.102
JM2081	8.1	10	1.0 (带圆角)	0.075
JM2116	11	15	1.0	0.114
JM2023	11.5	10	1.0	0.086
JM2037	12	31	3×1.3 (带槽)	0.318
JM2728	12	13	1.2	0.125
JM2055	14.9	35.3	1.5	0.362
JM2034	15	20	2.5	0.366
JM2780	18	10	1.4	0.145
JM2742	18.5	40	3.0	0.812
JM2028	19	12.7	1.8	0.215
JM2028A	19	12.7	1.8 (带槽)	0.211
JM2038	20	12	1.5	0.180
JM2078	20	33	2.5	0.593
JM2022	21	12	1.0	0.126
JM2039	25	13	1.0/1.5	0.144/0.211
JM2046	25	8	2.0 (带圆角)	0.22
JM2077	25	33	2.5	0.63
JM2089	25	19	3.0	0.5
JM2070	27.5	13	1.0	0.151
JM2796	28	20	1.3	0.247
JM2094	30	15	2.0	0.328
JM2110	30	20	2.0	0.387
JM2121	30	25	3.0	0.650
JM2091	31	20	2.5	0.483
JM2006	31.7	12.7	1.0	0.161
QX-CL1	34	19	3.5	0.666
JM2061	34	35	5.0	1.376

型材编号 Sections NO.	A (mm)	B (mm)	T (mm)	重量 (kg/m)
JM2115	34.8	15	2.0 (带圆角)	0.352
JM2052	35	30.2	4.8×4 (带圆角)	1.092
JM2803	37	40	4.0	1.277
JM2002	38	13	1.0	0.181
JM2029	38	20	0.9	0.201
CH10820	38.1	19	2.0	0.422
JM2095	40	20	3.0	0.65
JM2095A	40	20	2.0	0.445
JM2816	42	40	3.0	1.018
JM2113	47.8	30	1.2	0.370
JM2062	49	10	1.5	0.289
JM2008	50	13	1.2/1.5	0.258/0.321
JM2033	50	6.5	2.0 (带槽)	0.343
JM2107	50	25	2.0	0.559
JM2111	50	30	4.0	1.194
JM2815	50	60	3.0	1.440
JM2065	50.8	12.7	1.0	0.217
JM2088	52	23	2.0	0.55
JM2744	54.5	38	4.0	1.433
JM2096	60	30	3.0	1.001
JM2739	60	25	1.4	0.440
JM2808	65	45	5.0	2.122
JM2765	66.5	50	3.0	1.409
JM2041	68	10	4×5 (带圆角)	0.967
JM2047	70	26	2.0 (带圆角)	0.694
JM2048	70	40	2.0 (带圆角)	0.859
JM2083	73	13	1.0	0.284
JM2102	73	13	1.0	0.283
JM2053	76	23	1.0/1.5	0.351/0.523
JM2056	76	19	1.5×2 (带圆角)	0.534
JM2106	76	33.5	1.1	0.454
JM2842	77	20	3.0	0.974
JM2101	79.6	12	1.2	0.354
JM2040	80	15	1.1	0.347
JM2042	80	18	6.0 (带圆角)	1.824

型材编号 Sections NO.	A (mm)	B (mm)	T (mm)	重量 (kg/m)
JM2846	80	40	2.5	1.134
JM2043	82	15	1.2	0.384
JM2079	82	13	1.0	0.31
JM2097	84.5	16	1.2	0.401
JM2123	85.5	16	1.2	0.404
JM2044	88	23	1.0	0.387
JM2058	88	13	1.0	0.328
JM2059	88	18	1.1	0.392
JM2049	92.5	26	2.0 (带圆角)	0.826
JM2769	93.5	30	3.7	1.582
JM2781	93.5	30	3.7	1.582
JM2800	93.7	40	3.9	1.893
JM2100	99	25	1.2	0.515
JM2015A	100	13	1.2	0.434
JM2020	100	23	1.2	0.504
JM2057	100	25	1.8	0.771
JM2068	100	50	3.0	1.703
JM2090	100	20	2.5	0.988
JM2105	102	53.5	1.4	0.846
JM2064	104.5	25	1.0	0.446
JM2812	110	50	3.0	1.792
JM2025	120	24	2.0	0.960
JM2801	123.7	40	3.9	2.236
JM2104	124	53.5	1.4	0.935
JM2032	140	90	2.0 (带圆角)	1.919
JM2109	140	60	7×10 (带圆角)	5.986
JM2035	150	15	1.5	0.778
JM2072	150	80	12.0	10.042
JM2064A	155	25	1.5	0.887
JM2073	160	50	12 (带圆角)	8.286
JM2073A	160	75	12 (带圆角)	10.072
JM2092	172	4.5	2.5	1.287
JM2063	185	70	10×15 (带圆角)	10.694
JM2067	230	75	5.0 (带圆角)	5.412
JM2075	347	120	20.0	32.025

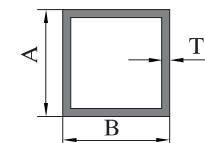

型材编号 Sections NO.	A (mm)	B (mm)	T (mm)	重量 (kg/m)
JM3044	12.8	12.8	1.2	0.163
JMFG0028	12.8	12.8	1.5 (圆角)	0.195
JMFG0143	13	13	1.7 (圆角)	0.219
JMFG0050	15	15	1.5	0.238
JM3060	15.6	15.6	1.2	0.202
JMFG0055	15.88	15.88	1.5	0.253
JMFG0055A	15.88	15.88	1.3	0.214
JM3039	16.2	16.2	1.2 (圆角)	0.205
JMFG0057	18	18	2.0 (圆角)	0.365
JMFG0013	19.05	19.05	1.2	0.251
JM3094	20	20	1.0/1.2/2.5	0.222/0.265/0.512
JM3040	20.1	20.1	1.5	0.326
JM3053	20.1	20.1	1.2/1.9 (圆角)	0.260/0.400
JMFG0058	22	22	2.0 (圆角)	0.459
JM3006	25	25	1.2/1.4/2.0	0.334/0.387/0.539
JM3034	25	25	1.5/2.0/3.0	0.413/0.539/0.772
JM3098	25.4	25.4	1.2	0.34
JMFG0935	26.5	26.5	1.2	0.355
JMFG0020	30	30	2.0	0.656
JMFG0148	30	30	2.0	0.656
JM3036	31	31	1.2/1.5	0.419/0.518
JM3011	32	32	1.6/2.3	0.569/0.800
JMFG0070	35	35	1.5	0.589
JM3014	38.1	38.1	1.3/1.5/2.0/3.1	0.561/0.643/0.846/1.270
JMFG0009	39.5	39.5	0.9	0.407

型材编号 Sections NO.	A (mm)	B (mm)	T (mm)	重量 (kg/m)
JM3015	40	40	1.0/2.0	0.457/0.890
JM3048	40	40	1.4/1.5/1.7	0.633/0.676/0.762
JMFG0881	40	40	2.5	1.399
JMFG0005	44.45	44.45	2.03	1.009
JMFG0113	45	45	2.0	1.007
JM3013	50	50	1.3/1.5/2.0/3.0	0.741/0.851/1.124/1.650
JM3013A	50	50	2.0 (圆角)	1.074
JM3087	50.8	50.8	2.0	1.143
JM3067	60	60	1.1/1.5	0.758/1.027
JM3047	63.5	63.5	1.4/2.0/3.1	1.017/1.440/2.192
JMFG0129	65	65	6.0	4.144
JMFG0770	65	65	2.5	1.828
JMFG0150	70	70	1.5	1.203
JMFG015012	70	70	1.2	0.967
JMFG0130	75	75	6.0	4.847
JMFG0088	76	76	1.2/1.4/1.5	1.051/1.223/1.308
JMFG0044	77.5	77.5	1.3	1.159
JM3093	80	80	1.4/2.0/3.0	1.288/1.826/2.704
JMFG0966	81.5	81.5	1.5	1.405
JMFG0074	82	82	1.2	1.135
JMFG0097	90	90	3.0	3.059
JMFG0861	95	95	1.5	1.642
JM3004	100	100	1.2/1.5/2.0/3.0	1.388/1.73/2.295/3.406
JM3009	101.6	101.6	1.3/2.286	1.526/2.658
JMFG0039	102.4	102.4	1.6	1.888
JMFG0031	150	150	3.0	5.166
JMFG003142	150	150	4.2	7.146
JMFG0017	160	160	3.0	5.512
JM3096	193	193	3.5	7.765
JMFG073855	200	200	5.5	12.524
JMFG074660	200	200	6.0	13.627

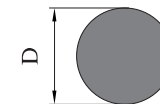

型材编号 Sections NO.	D (mm)	T (mm)	重量 (kg/m)
JMB100	6	实心棒	0.083
JMB037	8	实心棒	0.147
JMB066	8	实心棒	0.147
JMB065	10	实心棒	0.23
JMB110	12	实心棒	0.332
JMB109	13	实心棒	0.389
JMB113	14	实心棒	0.45
JMB108	15	实心棒	0.517
JMB098	16	实心棒	0.589
JMB117	16	实心棒	0.589
JMB046	16.5	实心棒	0.625
JMB112	19	实心棒	0.829
JMB127	20	实心棒	0.919
JMB107	21	实心棒	1.014
JMB124	22	实心棒	1.112
JMB115	23	实心棒	1.216
JMB116	24	实心棒	1.324
JMB036	25	实心棒	1.436
JMB111	26	实心棒	1.554
JMB081	27.5	实心棒	1.739
JMB120	28	实心棒	1.803
JMB080	30.5	实心棒	2.138
JMB119	31	实心棒	2.209
JMB079	35.5	实心棒	2.897
JMB114	41	实心棒	3.864
JMB126	57	实心棒	7.468
JMB389	60	实心棒	8.275
JMB118	81	实心棒	15.082

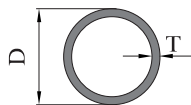

型材编号 Sections NO.	D (mm)	T (mm)	重量 (kg/m)
FZ0011	8	1.0	0.065
JMB139	10	1.0	0.083
JMB054	12	1.0/1.2	0.102/0.119
JMB012	12.7	1.0	0.056
JMB158	13	1.3	0.139
JMB121	14	1.5	0.173
JMB091	14.3	1.9	0.217
JMB034	15	1.4	0.175
JMB075	15.88	1.2	0.162
JMB064	16	1.6/3.0	0.213/0.359
JMB046A	16.5	1.3	0.181
JMB140	17.5	1.6	0.234
JMB084	18	1.0/1.5	0.157/0.228
JMB038	18.9	1.0	0.164
JMB038A	18.9	1.4	0.226
JMB001	19.5	1.2/1.6	0.202/0.264
JMB002	19.5	1.0	0.171
JMB069	20	2.0/2.5/3.0/5.0	0.332/0.402/0.469/0.690
JMB053	21.6	2.5	0.440
JMB057	21.8	1.7	0.314
JMB003	22	1.0/1.3/2.0	0.193/0.247/0.368
JMB013	24	1.2/1.5	0.252/0.310
JMB376	24.2	1.5	0.313
JMB166	25	1.2	0.262
JMB374	25	3.0	0.607
JMB051	25.2	2.2	0.464
JMB004	25.4	1.0/1.6/2.0/2.5	0.225/0.35/0.43/0.526
JMB004A	25.4	1.22	0.271
JMB096	26	1.5	0.338

型材编号 Sections NO.	D (mm)	T (mm)	重量 (kg/m)
JMB155	26	7.5	1.275
JMB133	26.5	3.5	0.740
JMB058	27.2	2.5	0.568
JMB032	28	2.0	0.478
JMB052	28	3.0	0.690
JMB092	28	8.75	1.549
JMB035	30	1.0	0.267
JMB154	30	4.85	1.149
JMB384	30	2.0	0.515
JMB123	31	2.5	0.656
JMB131	31	4.0	0.994
JMB043	32	1.3	0.367
JMB043A	32	6.0	1.434
JMB043B	32	10.75	2.101
JMB043C	32	1.05	0.299
JMB048	32	3.15	0.836
JMB070	32	3.0	0.800
JMB088	32.2	2.95	0.794
JMB373	32.2	3.0	0.806
JMB056	32.4	1.9	0.532
JMB101	33.5	5.25	1.364
JMB045	35	1.25/1.5	0.388/0.462
JMB094	36.4	2.5	0.780
JMB049	37	3.475	1.071
JMB009	38	1.5	0.503
JMB010	38	1.0/1.2/1.4/1.8	0.340/0.406/0.471/0.599
JMB040	38	2.0	0.662
JMB068	38.1	1.1/3.0	0.375/0.968
JMB134	38.5	1.5	0.511
JMB135	40	2.0	0.699
JMB090	40.1	3.0	1.024

型材编号 Sections NO.	D (mm)	T (mm)	重量 (kg/m)
JMB060	41	1.0	0.368
JMB078	41.5	3.0	1.062
JMB159	41.6	7.3	2.303
JMB146	42.00	1.5	0.558
JMB152	42	2.0	0.735
JMB157	42.7	2.0	0.748
JMB085	43	2.2	0.825
JMB041	43.5	2.2	0.836
JMB063	44	1.0	0.395
JMB128	44	18.0	4.303
JMB132	44.5	3.5/7.35	1.320/2.511
JMB173	45	1.3	0.523
JMB143	46	11.25	3.594
JMB055	48	2.2	0.927
JMB062	48	1.0	0.432
RT115	48.5	2.5	1.057
JMB153	48.8	2.6	1.105
JMB042	49	2.5	1.068
JMB008	50	1.2/1.50/2.0	0.539/0.669/0.882
JMB147	50	21.0	5.600
JMB151	50.2	3.0	1.302
JMB151A	50.2	3.1	1.342
JMB099	50.55	1.475	0.665
JMB437	50.8	1.25	0.569
JMB061	52	1.0	0.469
JMB136	54	1.5	0.717
JMB077	55.5	2.0	0.984
JMB077A	55.5	2.75	1.334
JMB178	56	6.75	3.056
JMB177	58	4.0	1.986
JMB030	60	1.5/5.0	0.807/2.528

型材编号 Sections NO.	D (mm)	T (mm)	重量 (kg/m)
JMB122	60	3.25	1.696
JMB388	61	4.25	2.217
JMB102	62	10.0	4.781
JMB102A	62	7.0	3.540
JMB007	63	1.3	0.738
JMB073	65	1.5	0.876
JMB076	65	6.75	3.616
JMB429	66	2.25	1.319
JMB087	70	3.0	1.848
JMB129	75	2.5	1.666
JMB071	80	1.3/1.8	0.941/1.294
JMB086	83	1.5	1.124
JMB148	85.1	13.8	9.047
JMB160	87.9	2.0	1.58
JMB072	95	2.5/3.0	2.127/2.538
JMB443	102	3.0	2.731
JMB104	103	1.8	1.675
JMB164	110	1.5	1.497
JMB161	113.5	2.2	2.252
JMB141	123.5	15.25	15.179
JMB149	125	6.0	6.565
JMB138	126	1.5	1.717
JMB162	140	2.5	3.161
JMB067	150	2.5	3.390
JMB083	160	4.0	5.738
JMB103	200.6	2.8	5.092
JMB074	203.2	3.0	5.522
JMB394	240	4.43	9.596
JMB392	500	6.0	27.254
JMB039A	15.8 (花管)	1.0	0.126
JMB039	19.6 (花管)	1.0/1.5	0.159/0.238

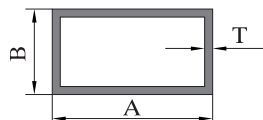

型材编号 Sections NO.	A (mm)	B (mm)	T (mm)	重量 (kg/m)
JM3063	15	8.5	0.9	0.114
JMFG017310	15	5	1.0 (带圆角)	0.103
JMFG018412	15	12	1.2	0.173
JMFG022715	15	10	1.5	0.193
JMFG0141	16	9	1.0	0.135
120.5-36	18	12	2.0 (圆角)	0.302
JM3025	18	14	1.2 (圆角)	0.208
JMFG019715	19	15	1.5 (圆角)	0.27
JMFG0103	19.05	12.7	1.3	0.22
JMFG0008	20	6	1.0	0.140
JMFG0108	20	9	2.0	0.293
JMFG018112	20	12.7	1.2	0.213
JMFG071112	20	9	1.2	0.187
JMFG0882	20	10	1.2	0.194
JMFG1089	20	10	1.2	0.194
JM3024	24	20	1.2 (圆角)	0.293
JMFG0021	24	22	1.5	0.378
JMFG0075	25	20	1.5	0.368
JMFG0114	25	15	2.0	0.421
JMFG017530	25	15	3.0	0.597
JMFG054420	25	18	2	0.457
JMFG1136	25	16	1.2	0.271
JM3027	25.4	12.7	1.0/1.3	0.212/0.270
JMFG0012	25.4	19.05	1.0	0.248
JMFG0810	25.4	12.7	1.2	0.251

型材编号 Sections NO.	A (mm)	B (mm)	T (mm)	重量 (kg/m)
JM3023	28	24	1.2 (圆角)	0.349
JM6754	30	15	1.0×1.3	0.264
JM3021	30	20	1.0/1.2/1.5/2.0	0.281/0.335/0.413/0.539
JM3042	30	15	1.5	0.369
JM3092	30	10	1.0	0.222
JMFG0002	30	22	1.0	0.293
JMFG0051	30	14	1.0	0.246
JMFG020510	30	15	1.0 (圆角)	0.234
JMFG0063	31	12.5	2.6	0.583
JMFG0136	31	19	3.0	0.772
JM3012	32	25	1.2/1.7	0.383/0.534
JM3064	34	10	1.0	0.246
JMFG021625	34	22.5	2.5	0.754
JMFG0133	34.8	25.8	2.0 (圆角)	0.633
JM120.3-7	35	14	3.5 (圆角)	0.855
JM3057	35	30	4×2 (带圆角)	1.047
JMFG0142	35	14	1.2	0.327
JMFG0904	35	30	3	1.036
JM3070	37	27	1.8 (圆角)	0.627
JMFG021510	37	25	1.0	0.351
JMFG0936	37	27	1.2	0.433
JMFG0001	37.8	25.1	1.0	0.356
JM3005A	38	25	2.0 (圆角)	0.671
JMFG0067	38	14	2.0	0.562
JM3005	38.1	25.4	1.0/1.4	0.360/0.498
JMFG0036	40	20	1.2/2.0	0.405/0.654
JMFG0149	40	30	2.0	0.772
JMFG017620	40	35	2.0	0.831
JMFG019418	40	10	1.8	0.489
JMFG0814	40	17	2	0.621
JMFG0828	40	30	3	1.124
JMFG0905	40	35	3	1.212
JMFG0090	40.6	21	1.6	0.546
JM3031	44	33	2.5	1.054
JMFG018625	44	40	2.5	1.156
JMFG0004	44.45	25.4	2.03	0.799
JMFG0007	45	17.5	1.0/2.0	0.354/0.685
JMFG0106	45	40	2.0	0.948

型材编号 Sections NO.	A (mm)	B (mm)	T (mm)	重量 (kg/m)
JMFG0038	46.7	22.6	1.5	0.583
JM3010	50	25	1.2/1.5/2.0/3.0	0.510/0.632/0.832/1.213
JM3011A	50	38	1.3/1.5/2.5	0.625/0.746/1.215
JM3038	50	40	2.0×3.0	1.217
JM3038A	50	40	2.5	1.244
JM3049	50	35	1.75×2.0 (圆角)	0.851
JM3089	50	13	1.4/2.0 (圆角)	0.477/0.671
JM3095	50	30	1.2/2.0/3.0	0.545/0.890/1.299
JMFG0003	50	38	1.2	0.602
JMFG0073	50	35	3.5	1.598
JMFG0131	50	20	1.0 (圆角)	0.391
JMFG0139	50	14	3.5	1.169
JMFG0177	50	10	1.0	0.339
JMFG019011	50	18.5	1.1	0.427
JMFG086450	50	39.5	5	2.326
JMFG0934	50	38	1.4	0.698
JMFG0006	50.5	25.1	1.0	0.431
JMFG0018	50.5	25	1.0×1.2	0.457
JM3065	50.8	12.7	1.2	0.429
JM3099	50.8	25.4	1.0	0.434
JMFG0111	52	30	1.2	0.559
JM3097	55	25	1.1	0.501
JMFG0874	55	40	3.5	1.803
JMFG087420	55	40	2	1.065
JMFG1013	55.9	17.5	1.5	0.618
JMFG0085	56	14	1.5	0.589
JM6403	57	50	1.5	0.914
JMFG0022	59.5	25	1.8×2.0 (圆角)	0.877
JM3058	60	30	1.0/1.5/2.3	0.515/0.764/1.149
JM3069	60	25.4	2.0	0.953
JM3069A	60	25	1.2	0.58
JMFG0016	60	15	1.0 (圆角)	0.428
JMFG0035	60	30	5.0	2.341
JMFG0040	60	50	2.5	1.537
JMFG0083	60	10	1.2	0.475
JMFG0086	60	20	2.0	0.89
JMFG0087	60	40	3.0	1.65
JMFG0087A	60	40	1.0	0.573

型材编号 Sections NO.	A (mm)	B (mm)	T (mm)	重量 (kg/m)
JMFG0089	60	20	3.0	1.299
JMFG0116	60	30	2.0	1.007
JMFG0117	60	40	2.0	1.124
JMFG0117A	60	40	2.5	1.39
JMFG0138	60	55	1.2	0.791
JMFG008740	60	40	4	2.155
JMFG0793	60	44	3	1.720
JMFG1050	60	30	1.5	0.764
JMFG1059	60	35	1.2	0.650
JMFG1012	61	17.5	1.5	0.663
JM3075	62	42	5.0 (带斜角)	2.785
JMFG0034	63	50	1.2	0.777
JMFG0817	63.5	50	3	1.888
JMFG0068	64	53	3.0	1.949
JMFG0077	65	40	1.5	0.895
JMFG0112	65	45	3.0	1.826
JMFG1014	65	56.5	3	2.028
JM3068	66	20	1.4	0.68
JM3035	67	25	1.2	0.63
JM3081	68	44	1.2	0.770
JM3086	70	25	1.0/1.3	0.544/0.703
JMFG0069	70	30	2.0	1.124
JMFG0096	70	23	1.2	0.636
JMFG0154	70	40	1.1	0.694
JMFG017020	70	36.5	2.0	1.2
JMFG022814	70	20	1.4	0.715
JMFG0901	70	35	1.2	0.720
JMFG0120	70.2	61.7	3	2.211
JMFG0178	71	13	1.0	0.48
JMFG0858	73	35	2	1.217
JM3079	74	72	1.5	1.256
JM3055	75	25	1.2	0.686
JMFG0805	75	50	1.4	1.001
JM3003	76	25	1.2/1.5/2.0/3.0	0.692/0.861/1.135/1.669
JM3008	76	44	1.2/1.5/2.0/3.0	0.826/1.027/1.358/2.002
JM3018	76	38	1.0/1.2/1.4	0.656/0.784/0.912
JMFG0107	76	31	2.5 (圆角)	1.483
JMFG016412	76	20	1.2	0.658

型材编号 Sections NO.	A (mm)	B (mm)	T (mm)	重量 (kg/m)
JMFG0804	76	38	1.2	0.784
JM3077	76.2	25.4	1.0	0.583
JMFG018040	77.5	56	4.0	2.939
JMFG0010	79.5	19.5	0.9	0.512
JM3054	80	50	1.4/3.0	1.042/2.177
JM3056	80	47	2.0	1.44
JM3059	80	40	1.0/1.5/3.0	0.691/1.027/2.002
JM3061	80	44	1.2	0.854
JM3062	80	25	1.2	0.72
JMFG0029	80	38	1.4	0.944
JMFG0053	80	60	1.5	1.203
JMFG0071	80	60	2.0	1.595
JMFG0072	80	30	1.5	0.942
JMFG0079	80	40	3.0	2.002
JMFG0132	80	10	2.0 (圆角)	0.997
JMFG0162A30	80	70	3.0 (圆角)	2.476
JMFG021420	80	40	2.0	1.358
JMFG0790	80	25	2	1.183
JMFG0799	80	72	1.5	1.308
JMFG0854	80	50	1.4	1.042
JMFG0095	81	37	2.5	1.653
JM3073	82	25	1.2	0.734
JM3076	82	44	1.2	0.868
JMFG0099	82	42	2.0 (圆角)	1.395
JM3082	88	44	1.1/1.2/2.5	0.836/0.910/1.859
JM3088	88	25	1.1	0.714
JMFG079640	88	38	4	2.763
JM3029	90	35	0.9/1.1/1.4	0.649/0.791/1.001
JM3043	90	25	0.9/1.2/1.5/3.0	0.596/0.792/0.984/1.914
JMFG0118	90	40	2.0	1.475
JMFG0122	90	50	3.0	2.354
JMFG0815	90	15	2	1.183
JM3026	93	25	1.0/1.3	0.679/0.878
JM3022	95	25	1.2	0.826
JMFG0076	95	50	1.5	1.246
JM3071	96	25	1.0/1.3	0.697/0.901
JM3001	100	25	1.1/1.5/1.8/3.0	0.791/1.071/1.279/2.091
JM3002	100	45	1.0/1.2/1.5/2.0	0.837/1.001/1.246/1.650



型材编号 Sections NO.	A (mm)	B (mm)	T (mm)	重量 (kg/m)
JM3007	100	44	1.3/1.5/2.0/3.0	1.076/1.238/1.639/2.424
JM3045	100	75	2.0/3.0	2.002/2.969
JM3066	100	44	3.5×6.5	3.457
JM3072	100	60	1.4	1.288
JM3084	100	76.2	1.2	1.220
JMFG0032	100	50	1.2/1.5/2.0/2.5	1.037/1.291/1.710/2.122
JMFG0033	100	65	2.0	1.885
JMFG0066	100	55	2.0/2.5	1.768/2.196
JMFG0109	100	20.5	1.8	1.231
JMFG0032B30	100	50	3	2.528
JMFG086620	100	40	2	1.592
JMFG025830	100	30	3	2.177
JMFG056320	100	80	2	2.061
JM3019	101.6	25.4	1.2/1.5/1.6	0.875/1.089/1.160
JM3020	101.6	44.5	1.2/1.6/2.5/3.0	1.010/1.338/2.065/2.460
JM3020A	101.6	44.5	2.5	2.065
JMFG0803	101.6	44.5	1.2	1.010
JMFG0104	102	44	2.0	1.661
JMFG0082	104	75	3.0	3.038
JMFG0064	105	55	1.7/1.8/3.0	1.560/1.648/2.704
JM3037	105.8	44	1.5/2.0	1.288/1.706
QXA-BXT2	106.5	23.6	3.0 (圆角)	2.142
JMFG0791	106.5	20	1.5	1.084
JMFG0027	108	105	1.6 (圆角)	2.187
JMFG0048	109.3	56.8	2.2	2.036
JMFG0011	110	75	1.5	1.598
JMFG0052	110	62	1.5	1.485
JMFG0153	110	70	3.0	3.055
JMFG019820	110	55	2.0	1.885
JMFG0795	110	60	2	1.943
JMFG1079	110	50	3	2.704
JMFG1135	110	30	2	1.592
JM3028	120	44	3.0/3.1	2.775/2.863
JM3046	120	30	1.6	1.375
JM3074	120	45	5.0 (带斜角)	4.564
JMFG0084	120	15	1.3×2.0	1.032
JMFG0102	120	25	3.0	2.441



型材编号 Sections NO.	D (mm)	T (mm)	重量 (kg/m)
BT4069	6	4.00	0.070
BT4068	8	3.0 (圆角)	0.070
BT4363	9	6.00	0.158
BT4060	10	5.00	0.147
BT4040	11	3.00	0.096
BT4040A	11.5	2.5 (圆角)	0.084
BT4031	12	3.00	0.106
BT4040B	12	2.50	0.087
BT4097	12	8.00	0.281
BT4087	12.7	4.80	0.178
BT4039	15	6.00	0.264
BT4035	15.5	2.50	0.113
BT4093	15.88	3.18	0.147
BT4063	16	6.00	0.281
BT4036	17	2.00	0.099
BT4080	17	6.80	0.338
JM6034	18	3.00	0.158
BT4032	19	3.80	0.212
BT4091	19.05	4.76	0.266
BT4092	19.05	1.27 (圆角)	0.07
BT4044	20	10.00	0.583
BT4081	20	5.00	0.293
BT4064	21	3.00	0.185
BT4052	21.5	2.00	0.126

型材编号 Sections NO.	D (mm)	T (mm)	重量 (kg/m)
BT4046	22	6.00	0.387
BT4084	22	5.00	0.322
BT4038	25	5.00	0.365
BT4062	25	3.00	0.219
BT4073	25	4.00	0.293
BT4012	25.4	2.0/2.8	0.149/0.208
BT4048	25.4	0.95	0.070
TF0106	25.4	6.35 (圆角)	0.447
BT4065	30	6.00	0.527
BT4098	30	12.00	1.054
BT4099	30	3.00	0.264
BT4375	30	4.00	0.351
TEX102	31.75	2.00	0.186
BT4074	32	3.00	0.281
BT4088	32	12.00	1.124
BT4034	34	3.00	0.298
BT4104	34	6.00	0.597
BT4089	35	3.00	0.308
BT4045	36	2.00	0.211
BT4079	36	3.00	0.316
BT4107	36	1.20	0.126
BT4108	38	9.00	1.001
BT4086	38.1	6.35	0.708
BT4100	40	6.00	0.702
BT4102	40	4.00	0.469
BT4106	40	5.00	0.585
BT4095	41	6.00	0.72
BT4059	44.45	8.00	1.041
JM15007	45	5.00	0.659
BT4030	45	2.00	0.264

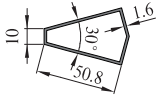
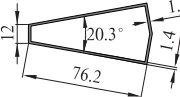
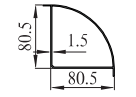
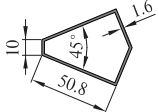
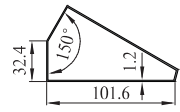
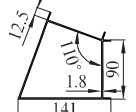
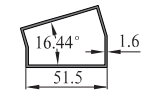
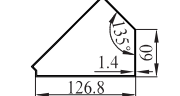
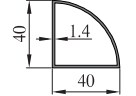
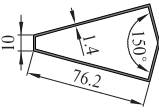
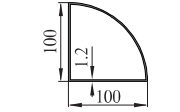
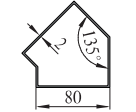
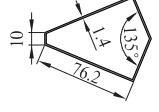
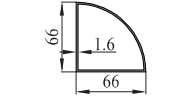
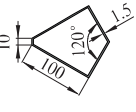
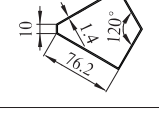
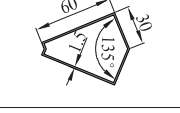
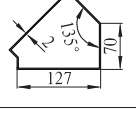
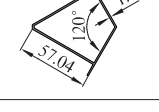
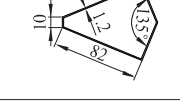
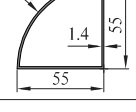
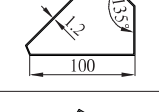
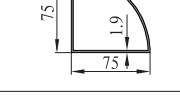
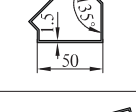
型材编号 Sections NO.	D (mm)	T (mm)	重量 (kg/m)
BT4415	46	2.50	0.337
BT4021	50	3.00	0.44
BT4047	50	4.00	0.585
BT4090	50	12.00	1.756
BT4078	57	10.00	1.666
BT4041	60	10.00	1.756
BT4070	60	12.00	2.107
BT4101	60	6.00	1.054
BT4076	71	2.00	0.416
BT4112	75	5.90	1.295
BT4452	75	1.40	0.308
BT4037	80	10.00	2.339
BT4057	88	10.00	2.576
BT4033	90	6.00	1.58
BT4405	92.7	6.00	1.628
BT4113	95	8.00	2.225
BT4424	120	29.00	10.185
BT4072	140	20.00	8.185
BT4005	150	10.00	4.39
BT4005A	150	8.00	3.512
BT4042	150	15.00	6.586
BT4071	160	20.00	9.356
BT4043	170	10.00	4.976
BT4043A	170	8.00	3.967
BT4001	200	20.00	11.707
BT4002	200	15.00	8.78
BT4004	200	10.00	5.854
BT4075	203	35.50	21.092
BT4109	220	16.00	10.302
BT4111	304.8	9.50	8.475

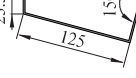
序号 S/N	型号理论重量 JMA Code & KG/M	型材图 Drawing	序号 S/N	型号理论重量 JMA Code & KG/M	型材图 Drawing	序号 S/N	型号理论重量 JMA Code & KG/M	型材图 Drawing
1	ZJM120116 0.671kg/m		10	ZJM1210 0.840kg/m		19	ZJM122415 1.317kg/m	
2	ZJM120216 0.742kg/m		11	ZJM121312 0.960kg/m		20	ZJM122618 2.521kg/m	
3	ZJM120416 0.760kg/m		12	ZJM121414 1.569kg/m		21	ZJM123014 0.564kg/m	
4	ZJM1205A14 0.853kg/m		13	ZJM121712 1.238kg/m		22	ZJM123120 1.793kg/m	
5	ZJM1206A14 0.947kg/m		14	ZJM121816 1.076kg/m		23	ZJM123615 1.455kg/m	
6	ZJM1207A14 1.052kg/m		15	ZJM121915 0.809kg/m		24	ZJM126020 2.463kg/m	
7	ZJM1207B14 0.828kg/m		16	ZJM122112 0.872kg/m		25	ZJM1262 0.783kg/m	
8	ZJM120812 1.053kg/m		17	ZJM122220 1.449kg/m		26	ZJM126315 0.758kg/m	
9	ZJM120920 1.960kg/m		18	ZJM122314 1.146kg/m		27	ZJM1264 2.090kg/m	

图中所示型材截面、装配、编号、尺寸及重量仅供参考。如有疑问，请向本公司查询。
 Information above just for your reference. Please contact us if you have any questions, Thank you!

图中所示型材截面、装配、编号、尺寸及重量仅供参考。如有疑问，请向本公司查询。
 Information above just for your reference. Please contact us if you have any questions, Thank you!

序号 S/N	型号理论重量 JMA Code & KG/M	型材图 Drawing	序号 S/N	型号理论重量 JMA Code & KG/M	型材图 Drawing	序号 S/N	型号理论重量 JMA Code & KG/M	型材图 Drawing
1	PC4046A 0.725kg/m		10	JM4011A 0.870kg/m		19	JMGR5257 1.723kg/m	
2	CKZA0009 0.964kg/m		11	JM15011 1.118kg/m		20	HGM12 1.082kg/m	
3	CKZA0010 1.037kg/m		12	JM402660 1.176kg/m		21	JM3806B 1.207kg/m	
4	PC4046 0.834kg/m		13	PC7007 1.402kg/m		22	JM11021 1.349kg/m	
5	JM400648 0.719kg/m		14	JM4026A66 0.935kg/m		23	JM3806 1.261kg/m	
6	JM3856 0.890kg/m		15	PC5026 1.601kg/m		24	PC386682 1.475kg/m	
7	JM3836 1.080kg/m		16	PC5026A 1.331kg/m		25	JM3824 1.331kg/m	
8	JM4011 0.865kg/m		17	PC5026B 1.096kg/m		26	Y14524 1.408kg/m	
9	Y14523 0.948kg/m		18	PC5026E 1.280kg/m		27	Y14524A 1.754kg/m	

序号 S/N	型号理论重量 JMA Code & KG/M	型材图 Drawing	序号 S/N	型号理论重量 JMA Code & KG/M	型材图 Drawing	序号 S/N	型号理论重量 JMA Code & KG/M	型材图 Drawing
28	GRQ5509 2.690kg/m		37	JM5004 2.448kg/m		46	JMGR5716 1.898kg/m	
29	JMGR5257B 2.262kg/m		38	GRE5527 1.315kg/m		47	GRE5528 1.966kg/m	
30	JMGY0881 2.550kg/m		39	GRF8009 3.525kg/m		48	GRE5528A 1.993kg/m	
31	JMGR5505A 3.169kg/m		40	MQ18100 2.802kg/m		49	JMGR5206 2.351kg/m	
32	JM16054 1.764kg/m		41	GRC7208A 2.727kg/m		50	PC5096 3.027kg/m	
33	F-50625 1.786kg/m		42	JM5086 3.027kg/m		51	JM6675 3.251kg/m	
34	GRB506 2.991kg/m		43	JMGR9013 2.051kg/m		52	TA5808 1.557kg/m	
35	GRW6118A 2.429kg/m		44	LT6019A 2.507kg/m		53	JM3806A 4.002kg/m	
36	JM5004A 2.354kg/m		45	GRE5507 2.256kg/m		54	PC5096A 3.072kg/m	

图中所示型材截面、装配、编号、尺寸及重量仅供参考。如有疑问，请向本公司查询。
Information above just for your reference. Please contact us if you have any questions, Thank you!

图中所示型材截面、装配、编号、尺寸及重量仅供参考。如有疑问，请向本公司查询。
Information above just for your reference. Please contact us if you have any questions, Thank you!

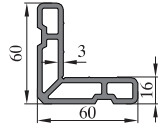
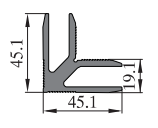
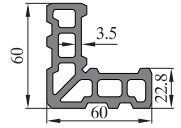
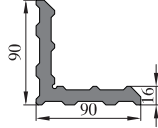
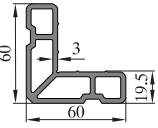
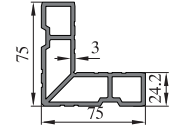
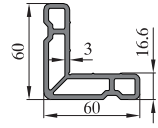
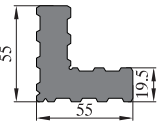
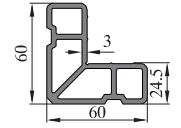
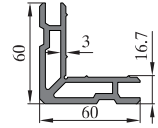
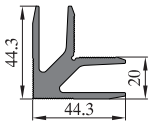
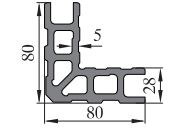
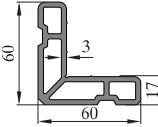
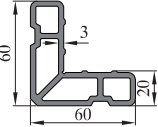
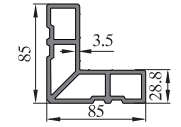
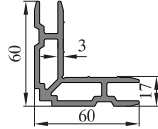
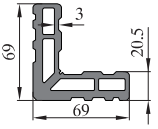
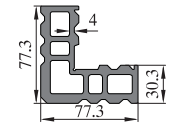
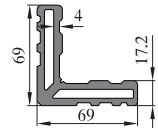
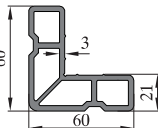
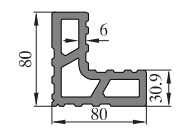
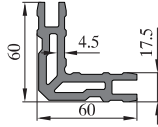
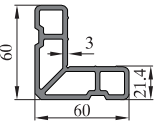
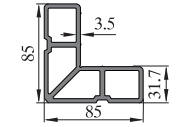
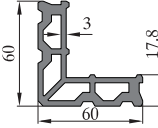
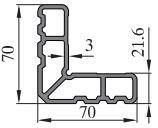
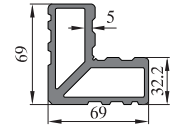
序号 S/N	型号理论重量 JMA Code & KG/M	型材图 Drawing	序号 S/N	型号理论重量 JMA Code & KG/M	型材图 Drawing	序号 S/N	型号理论重量 JMA Code & KG/M	型材图 Drawing
55	JMGR6036B 2.247kg/m		64	GRC7628 1.744kg/m		73	C-5029 3.320kg/m	
56	JMKA0029A 5.618kg/m		65	JMGR5008 2.351kg/m		74	B-5017A30 3.021kg/m	
57	JMGR6517 2.224kg/m		66	JMGR5257A 4.608kg/m		75	JMGR6047 2.502kg/m	
58	PC6047 2.311kg/m		67	GRF8005 1.749kg/m		76	JMGR7010A 5.431kg/m	
59	JMGR6036 2.278kg/m		68	JMGR5008A 2.381kg/m		77	JMGR5217 4.264kg/m	
60	JMGR6036C 2.076kg/m		69	JMGR5505D 4.125kg/m		78	LT6019 5.668kg/m	
61	JM5508 3.533kg/m		70	D603630 2.343kg/m		79	JMGY5957 6.627kg/m	
62	JMGR7010 2.968kg/m		71	B-5007B 2.409kg/m		80	JMGR6059A 4.263kg/m	
63	GRW6118 2.778kg/m		72	C-5046 2.787kg/m		81	JMGR5505B 3.975kg/m	

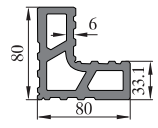
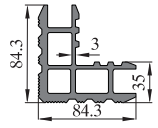
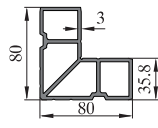
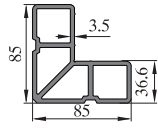
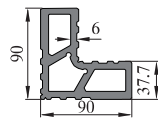
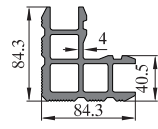
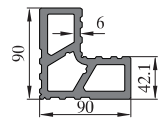
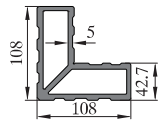

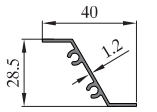
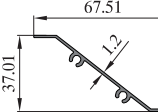
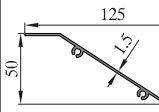
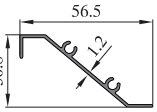
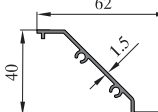
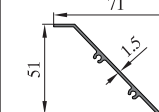
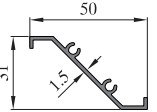
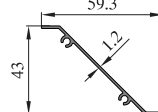
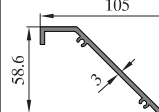
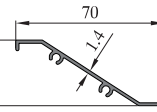
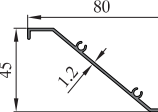
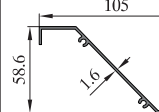
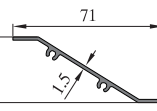
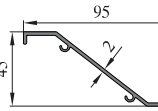
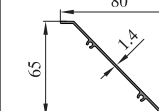
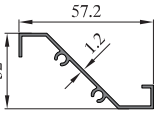
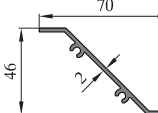
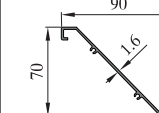
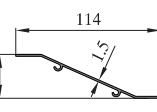
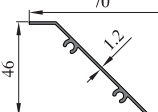
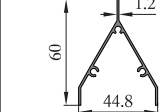
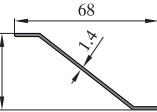
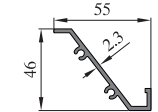
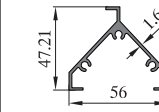
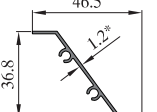
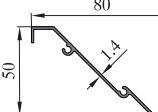
序号 S/N	型号理论重量 JMA Code & KG/M	型材图 Drawing	序号 S/N	型号理论重量 JMA Code & KG/M	型材图 Drawing	序号 S/N	型号理论重量 JMA Code & KG/M	型材图 Drawing
82	JMGR5236A 6.706kg/m		91			100		
83	GRQ5508 5.341kg/m		92			101		
84	E5055 3.568kg/m		93			102		
85	JMGR6059 4.458kg/m		94			103		
86	JMGR5236 7.735kg/m		95			104		
87	GRU5506 5.869kg/m		96			105		
88	JMGR5249 7.907kg/m		97			106		
89	JMGR5505C 7.855kg/m		98			107		
90			99			108		

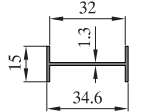
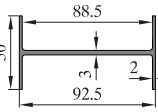
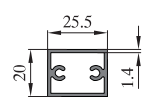
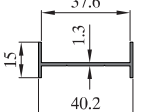
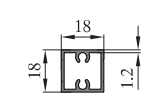
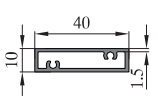
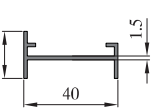
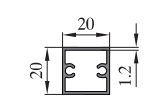
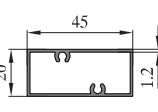
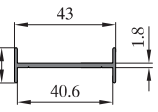
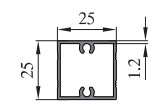
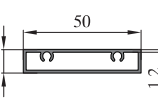
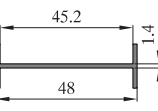
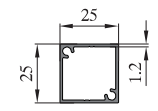
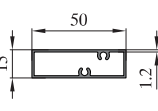
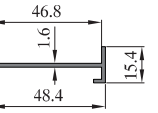
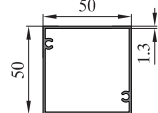
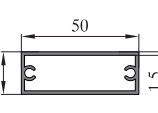
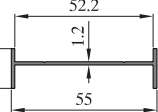
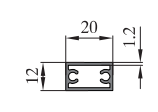
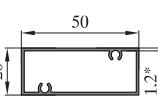
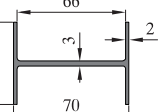
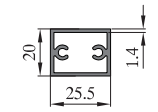
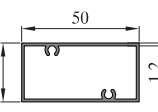
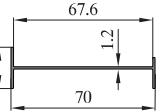
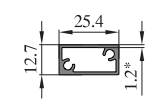
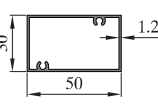

序号 S/N	型号理论重量 JMA Code & KG/M	型材图 Drawing	序号 S/N	型号理论重量 JMA Code & KG/M	型材图 Drawing	序号 S/N	型号理论重量 JMA Code & KG/M	型材图 Drawing
1	JMGY0157 0.278kg/m		10	JM603512 0.375kg/m		19	JM622515 0.767kg/m	
2	JMGY0146A 0.337kg/m		11	JMGY0633 0.455kg/m		20	B-5089A15 0.517kg/m	
3	JMGY0181A 0.372kg/m		12	JMGY4904 0.343kg/m		21	JMGY2059 1.367kg/m	
4	JM6348 0.431kg/m		13	JM6330 0.478kg/m		22	JMGY2059A 0.788kg/m	
5	B-508915 0.461kg/m		14	JM6539 0.804kg/m		23	JMGY10335 0.525kg/m	
6	JMGY0181 0.388kg/m		15	JM645320 0.698kg/m		24	JMGY1245 0.730kg/m	
7	JMGY0125 0.613kg/m		16	JM6453 0.449kg/m		25	JMGY16549 0.503kg/m	
8	JMGY8119 0.326kg/m		17	JM6802 0.697kg/m		26	JMGY3796 0.774kg/m	
9	JM638412* 0.287kg/m		18	JM6135 0.546kg/m		27		

序号 S/N	型号理论重量 JMA Code & KG/M	型材图 Drawing	序号 S/N	型号理论重量 JMA Code & KG/M	型材图 Drawing	序号 S/N	型号理论重量 JMA Code & KG/M	型材图 Drawing
28	JM6386A 0.235kg/m		37	JM6687 1.373kg/m		46	JMGY2420 0.470kg/m	
29	JM6386 0.257kg/m		38	JMGY16737 0.299kg/m		47	JMGY8313 0.465kg/m	
30	JM6386B 0.347kg/m		39	JMGY11887 0.328kg/m		48	JMGY8720 0.516kg/m	
31	JMGY8202 0.316kg/m		40	JMGY1496A 0.403kg/m		49	JMGY7499 0.451kg/m	
32	JMGY16548 0.308kg/m		41	JMGY1748 0.375kg/m		50	JMGY10857 0.514kg/m	
33	B-507016 0.339kg/m		42	JMGY6703 0.810kg/m		51	JMGY3206 0.640kg/m	
34	JMGY2162 0.306kg/m		43	JMGY2518 0.272kg/m		52	JMGY7130 0.522kg/m	
35	JM6686 1.175kg/m		44	JMGY2724 0.464kg/m		53	JMGY10066 0.576kg/m	
36	JMGY10334 0.360kg/m		45	JMGY8497 0.328kg/m		54	JMGY10856 0.619kg/m	

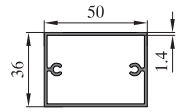
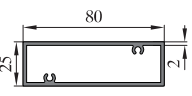
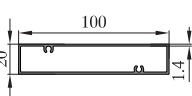
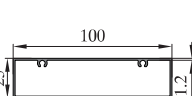
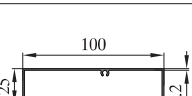
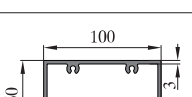
图中所示型材截面、装配、编号、尺寸及重量仅供参考。如有疑问，请向本公司查询。
 Information above just for your reference. Please contact us if you have any questions, Thank you!

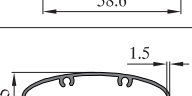
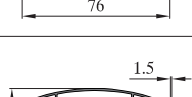
图中所示型材截面、装配、编号、尺寸及重量仅供参考。如有疑问，请向本公司查询。
 Information above just for your reference. Please contact us if you have any questions, Thank you!

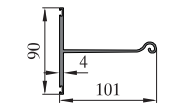
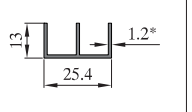
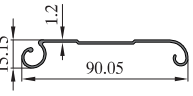
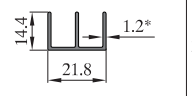
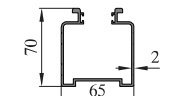
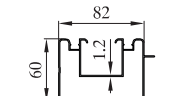
序号 S/N	型号理论重量 JMA Code & KG/M	型材图 Drawing	序号 S/N	型号理论重量 JMA Code & KG/M	型材图 Drawing	序号 S/N	型号理论重量 JMA Code & KG/M	型材图 Drawing
55	JMGY8118 0.796kg/m		64			73		
56	JMGY9867 1.284kg/m		65			74		
57	JMGY6740 1.037kg/m		66			75		
58	JMGY9426 0.931kg/m		67			76		
59	JMGY9461 0.922kg/m		68			77		
60	JMGY10372 3.308kg/m		69			78		
61	JM651112* 0.491kg/m		70			79		
62	JM6736 0.929kg/m		71			80		
63	JMGY1353 1.364kg/m		72			81		

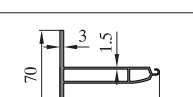
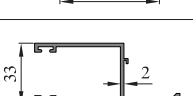
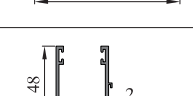
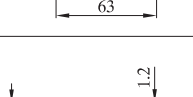
序号 S/N	型号理论重量 JMA Code & KG/M	型材图 Drawing	序号 S/N	型号理论重量 JMA Code & KG/M	型材图 Drawing	序号 S/N	型号理论重量 JMA Code & KG/M	型材图 Drawing
1	JM1150 1.724kg/m		10	JM630512* 0.214kg/m		19		
2	JM115112* 0.476kg/m		11	JM608412* 0.215kg/m		20		
3	JM1152 1.552kg/m		12			21		
4	JM1153 1.403kg/m		13			22		
5	JM1155C12* 0.610kg/m		14			23		
6	JM1156A 1.317kg/m		15			24		
7	JM1157 1.039kg/m		16			25		
8	JM1157A 1.039kg/m		17			26		
9	JM608212 0.847kg/m		18			27		

图中所示型材截面、装配、编号、尺寸及重量仅供参考。如有疑问，请向本公司查询。
 Information above just for your reference. Please contact us if you have any questions, Thank you!





图中所示型材截面、装配、编号、尺寸及重量仅供参考。如有疑问，请向本公司查询。
 Information above just for your reference. Please contact us if you have any questions, Thank you!



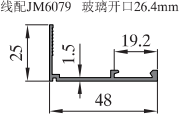
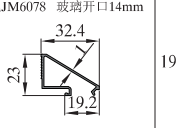
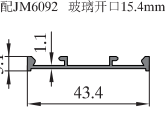
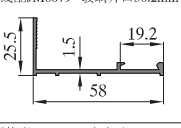
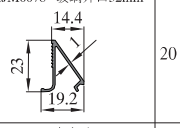
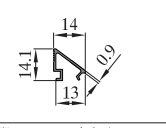
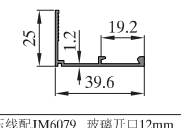
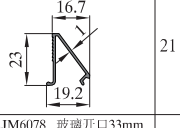
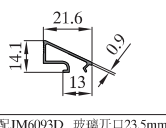
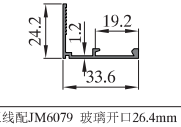
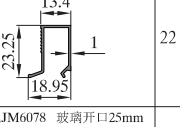
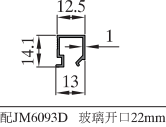
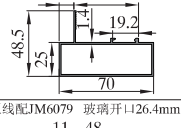
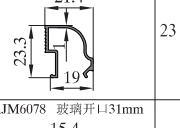
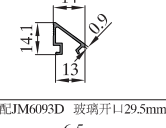
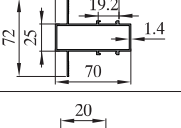

序号 S/N	型号理论重量 JMA Code & KG/M	型材图 Drawing	序号 S/N	型号理论重量 JMA Code & KG/M	型材图 Drawing	序号 S/N	型号理论重量 JMA Code & KG/M	型材图 Drawing
1	JM761012 0.292kg/m		10	JM906912* 0.449kg/m		19	TC1001815 0.525kg/m	
2	JM7610A12* 0.275kg/m		11	JM908912* 0.482kg/m		20	TC806312* 0.341kg/m	
3	JM7610B12* 0.367kg/m		12	JM9089A12* 0.418kg/m		21	TC8063A12* 0.320kg/m	
4	JM7630F12* 0.351kg/m		13	JM9089B12* 0.416kg/m		22	TC821012* 0.475kg/m	
5	JM765512* 0.428kg/m		14	JM9089D12* 0.423kg/m		23	TC8210A12* 0.369kg/m	
6	JM7655A12* 0.410kg/m		15	JM9089F12* 0.432kg/m		24	TC75A15 0.496kg/m	
7	JM7655D 0.362kg/m		16	JM9089G12* 0.505kg/m		25	TY6012 0.268kg/m	
8	JM851312* 0.403kg/m		17	JM9089H12* 0.406kg/m		26	JMSC0097 0.305kg/m	
9	JM8513A12* 0.404kg/m		18	JM9089J12* 0.482kg/m		27	JMTL6009 0.199kg/m	

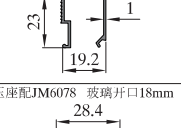
序号 S/N	型号理论重量 JMA Code & KG/M	型材图 Drawing	序号 S/N	型号理论重量 JMA Code & KG/M	型材图 Drawing	序号 S/N	型号理论重量 JMA Code & KG/M	型材图 Drawing
28	LT6020 0.274kg/m		37	JMGR6037R 0.685kg/m		46	E9090A 0.442kg/m	
29	PC503712 0.297kg/m		38	JMGR6087 0.279kg/m		47	JM5538B12* 0.409kg/m	
30	JMGY9986 0.399kg/m		39	JMGR7536A 0.347kg/m		48	JM6074A 0.495kg/m	
31	JMGY10855 0.422kg/m		40	JMGR8320 0.451kg/m		49	JM607612 0.294kg/m	
32	JMGR9008 0.496kg/m		41	JMGR3576 0.329kg/m		50	JM6077A 0.303kg/m	
33	JMGR9008A 0.521kg/m		42	JMGR5012 0.361kg/m		51	JM6329 0.395kg/m	
34	JMGR9008B 0.627kg/m		43	JMGR5227 0.249kg/m		52	JM7610D12 0.291kg/m	
35	JMGR9008C 0.553kg/m		44	JMGR5227A 0.271kg/m		53	TY6010 0.279kg/m	
36	JMGR5298B 0.295kg/m		45	E9090 0.376kg/m		54	TY6011 0.281kg/m	

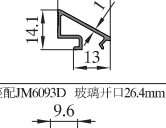
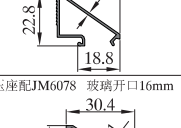
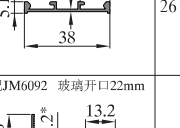
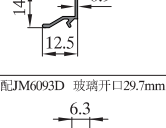
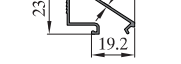
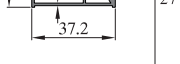
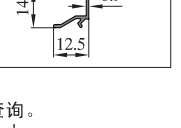
图中所示型材截面、装配、编号、尺寸及重量仅供参考。如有疑问，请向本公司查询。
 Information above just for your reference. Please contact us if you have any questions, Thank you!

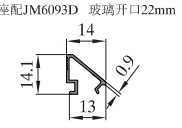
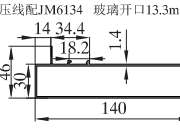
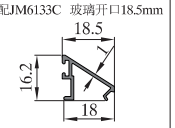
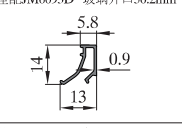
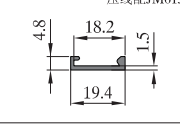
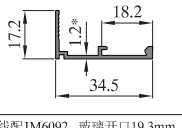
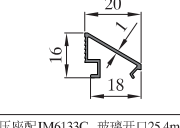
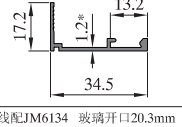
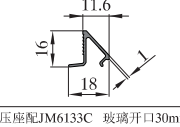
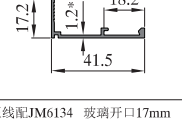
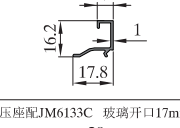
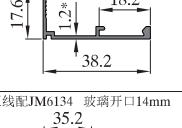
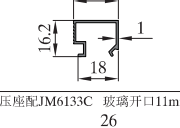

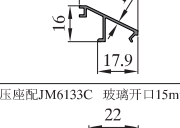

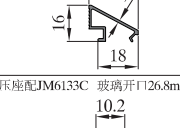
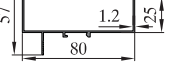
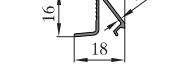



图中所示型材截面、装配、编号、尺寸及重量仅供参考。如有疑问，请向本公司查询。
 Information above just for your reference. Please contact us if you have any questions, Thank you!

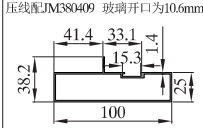
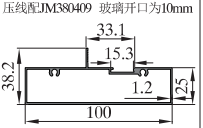
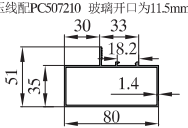
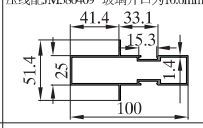
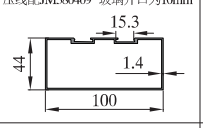
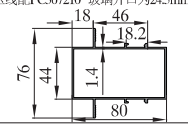
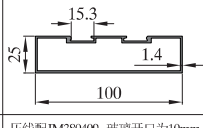
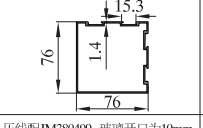
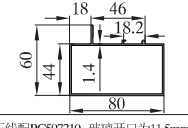
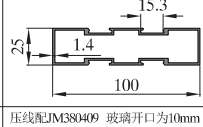
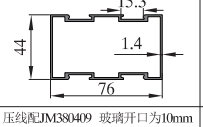
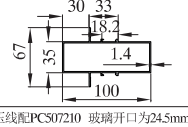
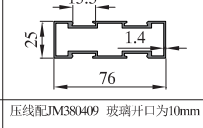
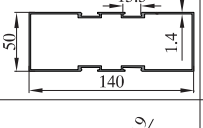

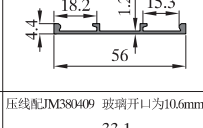

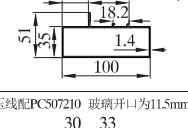

序号 S/N	型号理论重量 JMA Code & KG/M	型材图 Drawing	序号 S/N	型号理论重量 JMA Code & KG/M	型材图 Drawing	序号 S/N	型号理论重量 JMA Code & KG/M	型材图 Drawing
1	JM6078 0.340kg/m	压线配JM6079 玻璃开口26.4mm 	10	JM6079C 0.256kg/m	压座配JM6078 玻璃开口14mm 	19	JM6093E 0.224kg/m	压线配JM6092 玻璃开口15.4mm 
2	JM6078A 0.419kg/m	压线配JM6079 玻璃开口36.2mm 	11	JM6079D 0.176kg/m	压座配JM6078 玻璃开口32mm 	20	JM6092 0.108kg/m	
3	JM6078B 0.279kg/m	压线配JM6079 玻璃开口18mm 	12	JM6079G 0.175kg/m	压座配JM6078 玻璃开口29.7mm 	21	JM6092B 0.140kg/m	
4	JM6078C 0.255kg/m	压线配JM6079 玻璃开口12mm 	13	JM6079J 0.200kg/m	压座配JM6078 玻璃开口33mm 	22	JM6092C 0.130kg/m	
5	JM6078F 0.892kg/m	压线配JM6079 玻璃开口26.4mm 	14	JM6079K 0.215kg/m	压座配JM6078 玻璃开口25mm 	23	JM6092D09 0.107kg/m	
6	JM6078G 1.029kg/m	压线配JM6079 玻璃开口26.4mm 	15	JM6079M 0.205kg/m	压座配JM6078 玻璃开口31mm 	24	JM6092E 0.097kg/m	
7	JM6079 0.221kg/m		16	JM6093I2 0.171kg/m	压线配JM6092 玻璃开口10mm 	25	JM6092F 0.138kg/m	
8	JM6079A 0.233kg/m	压座配JM6078 玻璃开口18mm 	17	JM6093A12* 0.216kg/m	压线配JM6092 玻璃开口10mm 	26	JM6092G 0.102kg/m	
9	JM6079B 0.245kg/m	压座配JM6078 玻璃开口16mm 	18	JM6093D12* 0.222kg/m	压线配JM6092 玻璃开口22mm 	27	JM6092H 0.094kg/m	

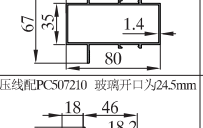
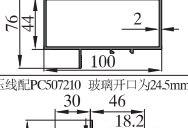
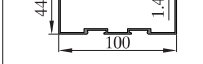
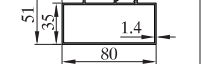
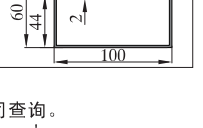
序号 S/N	型号理论重量 JMA Code & KG/M	型材图 Drawing	序号 S/N	型号理论重量 JMA Code & KG/M	型材图 Drawing	序号 S/N	型号理论重量 JMA Code & KG/M	型材图 Drawing
28	JM6092J 0.108kg/m	压座配JM6093D 玻璃开口22mm 	37	JM6133K 1.458kg/m	压线配JM6134 玻璃开口13.3mm 	46	JM6134K 0.147kg/m	压座配JM6133C 玻璃开口18.5mm 
29	JM6092K 0.103kg/m	压座配JM6093D 玻璃开口30.2mm 	38	JM6133L 0.126kg/m	压线配JM6134 	47		
30	JM6133I2* 0.218kg/m	压线配JM6134 玻璃开口13.3mm 	39	JM6134 0.145kg/m		48		
31	JM6133A12* 0.218kg/m	压线配JM6092 玻璃开口19.3mm 	40	JM6134A 0.137kg/m	压座配JM6133C 玻璃开口25.4mm 	49		
32	JM6133B12* 0.243kg/m	压线配JM6134 玻璃开口20.3mm 	41	JM6134B 0.127kg/m	压座配JM6133C 玻璃开口30mm 	50		
33	JM6133C12* 0.233kg/m	压线配JM6134 玻璃开口17mm 	42	JM6134C 0.173kg/m	压座配JM6133C 玻璃开口17mm 	51		
34	JM6133D 0.663kg/m	压线配JM6134 玻璃开口14mm 	43	JM6134D 0.158kg/m	压座配JM6133C 玻璃开口11mm 	52		
35	JM6133E 0.752kg/m	压线配JM6134 玻璃开口14mm 	44	JM6134E 0.157kg/m	压座配JM6133C 玻璃开口15mm 	53		
36	JM6133J 0.895kg/m	压线配JM6134 玻璃开口13.3mm 	45	JM6134H 0.121kg/m	压座配JM6133C 玻璃开口26.8mm 	54		

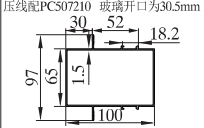
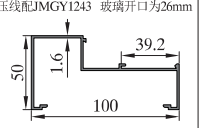
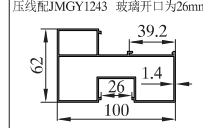
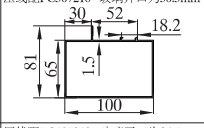
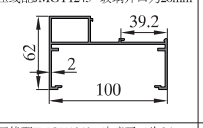
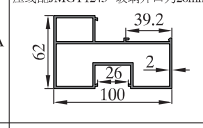
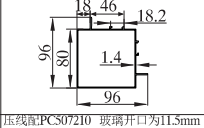
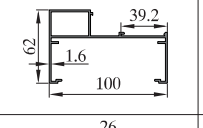
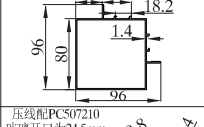
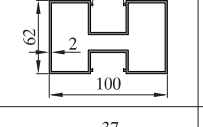
图中所示型材截面、装配、编号、尺寸及重量仅供参考。如有疑问，请向本公司查询。
 Information above just for your reference. Please contact us if you have any questions, Thank you!

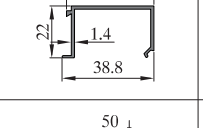
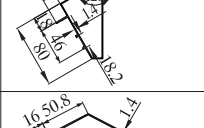
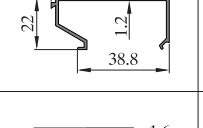
图中所示型材截面、装配、编号、尺寸及重量仅供参考。如有疑问，请向本公司查询。
 Information above just for your reference. Please contact us if you have any questions, Thank you!

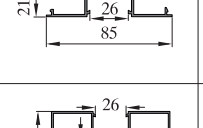
序号 S/N	型号理论重量 JMA Code & KG/M	型材图 Drawing	序号 S/N	型号理论重量 JMA Code & KG/M	型材图 Drawing	序号 S/N	型号理论重量 JMA Code & KG/M	型材图 Drawing
1	JM4025I4 1.095kg/m	压线配JM380409 玻璃开口为10.6mm 	10	JM4025H12 1.045kg/m	压线配JM380409 玻璃开口为10mm 	19	PC5065C14 1.041kg/m	压线配PCS07210 玻璃开口为11.5mm 
2	JM4025A14 1.190kg/m	压线配JM380409 玻璃开口为10.6mm 	11	JM4025R14 1.247kg/m	压线配JM380409 玻璃开口为10mm 	20	PC5065E14 1.238kg/m	压线配PCS07210 玻璃开口为24.5mm 
3	JM4025B14 1.096kg/m	压线配JM380409 玻璃开口为10.8mm 	12	JM4025X14 1.404kg/m	压线配JM380409 玻璃开口为10mm 	21	PC5065F14 1.116kg/m	压线配PCS07210 玻璃开口为24.5mm 
4	JM4025C14 1.190kg/m	压线配JM380409 玻璃开口为10mm 	13	JM4025Y14 1.142kg/m	压线配JM380409 玻璃开口为10mm 	22	PC506614 1.327kg/m	压线配PCS07210 玻璃开口为11.5mm 
5	JM4025CA14 0.994kg/m	压线配JM380409 玻璃开口为10mm 	14	JM4025ZA 1.715kg/m	压线配JM380409 玻璃开口为10mm 	23	PC5066A14 1.327kg/m	压线配PCS07210 玻璃开口为24.5mm 
6	JM4025CB12 0.280kg/m	压线配JM380409 玻璃开口为10mm 	15	JM380409 0.148kg/m		24	PC5066B14 1.205kg/m	压线配PCS07210 玻璃开口为24.5mm 
7	JM4025E12 0.777kg/m	压线配JM380409 玻璃开口为10.6mm 	16	PC506514 1.163kg/m	压线配PCS07210 玻璃开口为11.5mm 	25	PC5066C14 1.205kg/m	压线配PCS07210 玻璃开口为11.5mm 
8	JM4025F12 1.137kg/m	压线配JM380409 玻璃开口为10.6mm 	17	PC5065A14 1.163kg/m	压线配PCS07210 玻璃开口为24.5mm 	26	PC5066AA 1.884kg/m	压线配PCS07210 玻璃开口为24.5mm 
9	JM4025G14 1.342kg/m	压线配JM380409 玻璃开口为10mm 	18	PC5065B14 1.041kg/m	压线配PCS07210 玻璃开口为24.5mm 	27	PC5066BA 1.761kg/m	压线配PCS07210 玻璃开口为24.5mm 

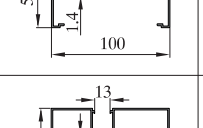
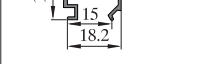
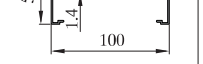
序号 S/N	型号理论重量 JMA Code & KG/M	型材图 Drawing	序号 S/N	型号理论重量 JMA Code & KG/M	型材图 Drawing	序号 S/N	型号理论重量 JMA Code & KG/M	型材图 Drawing
28	PC5066E15 1.666kg/m	压线配PCS07210 玻璃开口为30.5mm 	37	JMGY1240 1.081kg/m	压线配JMGY1243 玻璃开口为26mm 	46	JMGY1602 1.683kg/m	压线配JMGY1243 玻璃开口为26mm 
29	PC5066F15 1.544kg/m	压线配PCS07210 玻璃开口为30.5mm 	38	JMGY1241 1.706kg/m	压线配JMGY1243 玻璃开口为26mm 	47	JMGY1602A 2.348kg/m	压线配JMGY1243 玻璃开口为26mm 
30	PC506714 1.533kg/m	压线配PCS07210 玻璃开口为24.5mm 	39	JMGY1241A 1.403kg/m	压线配JMGY1243 玻璃开口为26mm 	48		
31	PC5067A14 1.533kg/m	压线配PCS07210 玻璃开口为11.5mm 	40	JMGY1242 2.421kg/m		49		
32	PC5068A14 1.327kg/m	压线配PCS07210 玻璃开口为24.5mm 	41	JMGY1243 0.335kg/m		50		
33	PC5069A14 1.105kg/m	压线配PCS07210 玻璃开口为24.5mm 	42	JMGY1243A 0.362kg/m		51		
34	PC5070A14 1.361kg/m	压线配PCS07210 玻璃开口为24.5mm 	43	JMGY1244 0.636kg/m		52		
35	PC5071A14 1.123kg/m	压线配PCS07210 玻璃开口为24.5mm 	44	JMGY1600 1.369kg/m		53		
36	PC507210 0.173kg/m		45	JMGY1601 1.422kg/m		54		

图中所示型材截面、装配、编号、尺寸及重量仅供参考。如有疑问，请向本公司查询。
 Information above just for your reference. Please contact us if you have any questions, Thank you!

图中所示型材截面、装配、编号、尺寸及重量仅供参考。如有疑问，请向本公司查询。
 Information above just for your reference. Please contact us if you have any questions, Thank you!

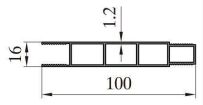
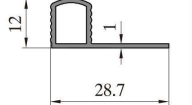
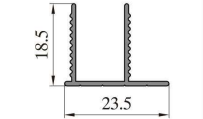
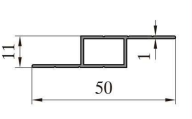
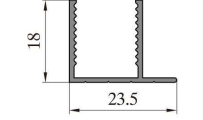
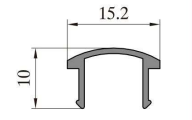
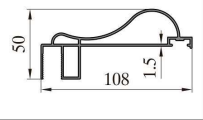
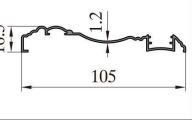
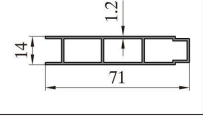
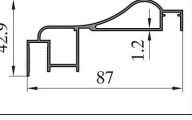
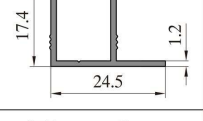
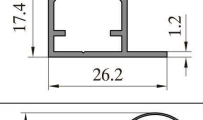
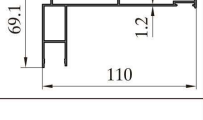
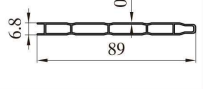
序号 S/N	型号理论重量 JMA Code & KG/M	型材图 Drawing	序号 S/N	型号理论重量 JMA Code & KG/M	型材图 Drawing	序号 S/N	型号理论重量 JMA Code & KG/M	型材图 Drawing
1	插板 TM120B69A T=1.2 0.968kg/m		10	连接件 JMGY22199 T=1 0.174kg/m		19		
2	连接件 TM120B69B T=1 0.173kg/m		11	连接件 JMGY22651 T=1 0.243kg/m		20		
3	连接件 TM120B69C T=1 0.187kg/m		12	装饰盖 JMGY22201 T=0.9 0.094kg/m		21		
4	装饰线 TM120B69 T=1.5 1.391kg/m		13	装饰线 JMGY22200 T=1.2 0.575kg/m		22		
5	插板 JMGR28587 T=1.2 0.661kg/m		14	装饰线 JMGY22198 T=1.2 0.875kg/m		23		
6	连接件 JMGR28586 T=1.2 0.201kg/m		15			24		
7	连接件 JMGR28594 T=1.2 0.228kg/m		16			25		
8	装饰线 JMGR28588 T=1.2 1.281kg/m		17			26		
9	插板 JMGY22650 T=0.8 0.484kg/m		18			27		

图中所示型材截面、装配、编号、尺寸及重量仅供参考。如有疑问，请向本公司查询。
 Information above just for your reference. Please contact us if you have any questions. Thank you!

广东坚美铝型材厂(集团)有限公司

Guangdong JMA Aluminium Profile Factory (Group) Co., Ltd.

地址: 中国广东省佛山市南海区大沥凤池工业区(广佛路大沥往佛山1公里)
 ADD: Fengchi Industrial Area, Dali Town, Nanhai District, Foshan City, Guangdong Province, China

佛山坚美铝业有限公司

Foshan JMA Aluminium Co., Ltd.

地址: 广东省佛山市南海区狮山镇桃园西路高新技术开发区南海园
 ADD: Nanhai Park, High-new Technology Zone, Tianyuan Road West, Shishan Town, Nanhai District, Foshan City, Guangdong Province, China

邮编(Zip): 528231 电话(Tel): 86-757-85558828 传真(Fax): 86-757-85550238
 网址(Website): <http://www.jma.cn> <http://www.jianmei-alu.com>
 电子邮箱(E-mail): sales@jma.cn jmmaster@jma.cn dd@jma.cn



坚美铝材
官方网站二维码



坚美铝业微信公众号
微信号: jmagroup